

INFORMAZIONI GENERALI

Il presente catalogo serve per richiedere con esattezza le parti di ricambio
Nelle ordinazioni indicare:

- 1) il numero di codice dei particolari seguito dalla descrizione;
- 2) il colore per i pezzi verniciati o comunque colorati;
- 3) il numero di matricola del motociclo, stampigliato sul canotto di sterzo.

Le indicazioni destra e sinistra si riferiscono ai lati del veicolo rispetto al senso di marcia.

GENERAL INFORMATION

The present spare parts list enables one to order exactly the right spare parts.

When ordering specify:

- 1) the part's code number followed by its description;
- 2) indicate colour for painted or coloured parts;
- 3) the motorcycle's serial number, stamped on the steering head.

References to right and left apply to the vehicle in terms of its direction of movement.

INFORMATIONS GENERALES

Ca catalogue permet de commander correctement les pièces de rechange.
Les commandes doivent être passées en indiquant:

- 1) le numéro de code des pièces détachées suivi de leur description;
- 2) le couleur des pièces peintes ou colorés;
- 3) le matricule de la moto, estampillé sur la tige du guidon.

Droite et gauche sont les côtés du véhicule par rapport au sens de la marche.

ALLGEMEINE HINWEISE

Dieser Ersatzteilkatalog dient zur genauen Angabe der Teile bei Ersatzteilbestellungen.

Bei Ersatzbestellung ist folgendes anzugeben:

- 1) Die Bestellnummer der Ersatzteile mit der entsprechenden Beschreibung;
 - 2) Farbe für lackierte und farbige Teile angeben;
 - 3) Die Sseriennummer des Motorrads, die am Lenkrohr eingepreßt ist.
- Die Angaben rechts und links beziehen sich auf das Fahrzeug in Fahrrichtung.

INFORMACIONES GENERALES

El presente catálogo sirve para pedir con exactitud las partes de recambio.
En los pedidos se debe indicar:

- 1) el número de código de la parte y a continuación la descripción;
- 2) el color para las piezas barnizadas o coloreadas;
- 3) el número de matrícula de la motocicleta, estampado en el tubo de dirección.

Las indicaciones derecha e izquierda se refieren a los lados del vehículo respecto del sentido de marcha.

NOTE - LIST - NOTES - NOTE - NOTAS:

- A** : In alternativa - In alternative - En alternative
Wahlweise - En alternativa
- D** : In dotazione - To issue - En necessaire
Ausrustungsteile - En dotación
- E** : Ad esaurimento - To fell out - A' finir - Erschöpfung
A agotamiento
- F** : Fornire assieme - Supply unitedly - Fournir ensemble
Wird zusammen geliefert - Equipar juntos
- M** : Modello SMR - SMR model - Modèle SMR - Modell SMR
Modélo SMR
- N** : Non fornito - Not supplied - Ne pas fournir
Keine Gelieferende - No equiparado
- R** : A richiesta - Upon request - Sur demande
Auf anfrage - Bajo pedido
- S** : Di serie - Supplied - De série - Standard - De serie
- U** : Solo per TE / U.S.A. - Only for TE / U.S.A. - Soulement pour
TE / U.S.A.- Nur für TE / U.S.A. - Solo por TE / U.S.A.
- X** : Non per U.S.A. - Not for U.S.A. - Ne pas pour U.S.A.
Keine für U.S.A. - No por U.S.A.
- XBR** : Non per Brasile- Not for Brazil - Ne pas pour Brasile
Keine für Brasilien - No por Brasil
- W** : Modello TE - TE model - Modèle TE - Modell TE
Modélo TE
- Z** : n° denti, number of teeth, numéro dents, Zähne nummer
número dientes
- (&), (@) : Montati assieme- Assembled together

- A** : Austria, Austria, Autriche, Österreich, Austria
- AUS** : Australia, Australia, Australie, Australien, Australia
- B** : Belgio, Belgium, Belgique, Belgien, Bélgica
- BR** : Brasile, Brazil, Brasile, Brasilien, Brasil
- CDN** : Canada, Canada, Canada, Kanada, Canadá
- CH** : Svizzera, Switzerland, Suisse, Schweizer, Suiza
- D** : Germania, Germany, Allemagne, Deutschland, Alemania
- E** : Spagna, Spain, Espagne, Spanien, España
- F** : Francia, France, France, Frankreich, Francia
- GB** : Gran Bretagna, Great Britain, Grand Bretagne
Groos Britan, Gran Bretaña
- I** : Italia, Italy, Italie, Italien, Italia
- J** : Giappone, Japan, Japon, Japan, Japón
- SF** : Finlandia, Finald, Finlande, Finnland, Finlandia
- USA** : Stati Uniti d'America, United States of America
Etats Units d'Amérique,
Vereinigte Staaten von Amerika, Estados Unidos

Il n° di matricola iniziale del modello **TE 570/2003** è **ZCGH601AA3V006900**
Il n° di matricola iniziale del modello **SMR 570/2003** è **ZCGH601AB3V001400**

The initial serial number for the **TE 570/2003** model is **ZCGH601AA3V006900**
The initial serial number for the **SMR 570/2003** model is **ZCGH601AB3V001400**

Le matricule initial du modèle **TE 570/2003** est **ZCGH601AA3V006900**
Le matricule initial du modèle **SMR 570/2003** est **ZCGH601AB3V001400**

Die Seriennummer des Modells **TE 570/2003** beginnt mit **ZCGH601AA3V006900**

Die Seriennummer des Modells **SMR 570/2003** beginnt mit **ZCGH601AB3V001400**

El n° de matricula inicial de la motocicleta **TE 570/2003** es **ZCGH601AA3V006900**
El n° de matricula inicial de la motocicleta **SMR 570/2003** es **ZCGH601AB3V001400**

Dati indicativi soggetti a modifiche senza impegno di preavviso.
All data are subject to modification without prior notice.
Données indicatif sujet au modifications sans obligation de préavis.
Anderungen Vorbehalten.
Datos indicativos sujetos a modificaciones sin compromiso de preaviso.

Tavola Drawing Table Bild Tabla	Denominazione	Description	Designation	Bezeichnung	Denominacion	Pagina Page Page Seite Paja
1	ATTREZZI DI ASSISTENZA, MANUALI E CATALOGHI	SERVICE TOOLS, MANUALS AND CATALOGS	OUTILS D'ASSISTANCE, MANUELS ET CATALOGUES	HILFAUSRUSTUNG, HANDBUCH UND KATALOG	HERRAMIENTAS DE ASISTENCIA, MANUALES Y CATALOGOS	11
2	TESTA, CILINDRO	CYLINDER HEAD, CYLINDER	CULASSE, CYLINDRE	ZYLINDERKOPF, ZYLINDER	CULATA, CILINDRO	15
3	DISTRIBUZIONE	VALVE TIMING	DISTRIBUTION	VENTILSTEUERUNG	DISTRIBUCION	19
4	PISTONE, MANOVELLISMO	PISTON, CRANKSHAFT	PISTON, VILEBREQUIN	KOLBEN, KURBELWELLE	PISTON, PALANCAS	23
5	RAFFREDDAMENTO	COOLING SYSTEM	REFROIDISSEMENT	WASSERKUEHLUNG	ENFRIAMIENTO	25
6	SEMICARTER DESTRO	R.H. HALF CRANKCASE	CARTER D.	GEHAUSEDECKEL R.	BANCADA DER.	27
7	SEMICARTER SINISTRO, AVVIAMENTO	L.H. HALF CRANKCASE, STARTING	CARTER G., DEMARRAGE	GEHAUSEDECKEL L., ANLASSER	BANCADA IZQ., ARRANQUE	31
8	CAMBIO, COMANDO CAMBIO, FRIZIONE	TRANSMISSION, SHIFTER, CLUTCH	BOITE DE VITESSE, COMMANDE DE VITESSE, EMBRAYAGE	WECHSELGETRIEBE, GANGSCHALTUNG ,KUPPLUNG	CAMBIO, MANDO CAMBIO , EMBRAGUE	37
9	ACCENSIONE	IGNITION	ALLUMAGE	ZUNDUNG	ENCENDIDO	43
10	CARBURATORE	CARBURETOR	CARBURATEUR	VERGASER	CARBURADOR	45
11	FILTRO ARIA	AIR FILTER	FILTRE AIRE	AIRFILTER	FILTRO DE AIRE	49
12	TELAIO, PEDANE	FRAME, FOOT RESTS	CADRE, REPOSE PIEDS	RAHMEN, FUSSRASTE	BASTIDOR, REPOSAPIES	51
13	SOSPENSIONE ANTERIORE	FRONT FORK ASSEMBLY	SUSPENSION AVANT	VORDERTELESKOPGABEL	SUSPENSION DELANTERA	55
14	FORCELLONE	SWING ARM	FOURCHE	HINTERGABEL	HORQUILLA TRASERA	63
15	AMMORTIZZATORE POSTERIORE	REAR SHOCK ABSORBER	AMMORTISSEUR ARRIERE	HINTERSTOSSDAMPFER	AMORTIGUADOR TRASERO	67
16	LEVERAGGI SOSPENSIONE POST.	REAR SUSPENSION LINKAGE	LEVIER SUSPENSION ARRIERE	HEBELWERK HINTERHAUFHANGUNG	PALANCA SUSPENSION TRASERA	71
17	MANUBRIO E COMANDI	HANDLEBAR AND CONTROLS	GUIDON ET COMMANDES	LENKER UND STEUERORGANE	MANILLAR Y MANDOS	73
18	FRENO IDRAULICO POSTERIORE	REAR HYDRAULIC BRAKE	FREIN HYDRAULIQUE ARRIERE	HINTERBREMSE	FRENO HIDRAULICO TRASERO	77
19	PANNELLI LAT., PARAFANGHI, SELLA	SIDE PANELS, FENDERS, SEAT	PANNEAU, GARDE-BOUES , SIEGE	STREIFEN, KOTFLUGEL, SATTEL	PANELES, GUARDABARROS, SILLIN	81
20	SERBATOIO CARBURANTE, CONVOGLIATORI	GAS TANK, PANELS	RESERVOIR CARBURANT, FLANCS	KRAFTSTOFFBEHALTER, FLANKE	DEPOSITO GASOLINA, LATERALES	85
21	SCARICO	EXHAUST SYSTEM	TUYAU D'ECHAPPEMENT	AUSPUFFROHR	TUBO DE ESCAPE	87
22	FRENO IDRAULICO ANTERIORE (TE)	FRONT HYDRAULIC BRAKE (TE)	FREIN HYDRAULIQUE AVANT (TE)	VORTERBREMSE (TE)	FRENO HIDRAULICO DELANTERO (TE)	89
22A	FRENO IDRAULICO ANTERIORE (SMR)	FRONT HYDRAULIC BRAKE (SMR)	FREIN HYDRAULIQUE AVANT (SMR)	VORTERBREMSE (SMR)	FRENO HIDRAULICO DELANTERO (SMR)	93
22B	RUOTA ANTERIORE (TE)	FRONT WHEEL (TE)	ROUE AVANT (TE)	VORTERRAD (TE)	RUEDA DELANTERA (TE)	97
22C	RUOTA ANTERIORE (SMR)	FRONT WHEEL (SMR)	ROUE AVANT (SMR)	VORTERRAD (SMR)	RUEDA DELANTERA (SMR)	99
23	RUOTA POSTERIORE	REAR WHELL	ROUE ARRIERE	HINTERRAD	RUEDA TRASERA	101
24	STRUMENTO DIGITALE (TE-SMR)	DIGITAL INSTRUMENT (TE-SMR)	INSTRUMENT DIGITAL (TE-SMR)	DIGITAL TACHOMETER (TE-SMR)	INSTRUMENTO DIGITAL (TE-SMR)	105

Tavola Drawing Table Bild Tabla	Denominazione	Description	Designation	Bezeichnung	Denominacion	Pagina Page Seite Seite Paja
25	IMPIANTO ELETTRICO, PORTATARGA, PORTAFARO ANTERIORE (TE-SMR)	ELECTRIC SYSTEM, PLATE HOLDER, HEADLAMP FAIRING (TE-SMR)	INSTALLATION ELECT.,PORTE-BALAI, DOME PORTE PHARE (TE-SMR)	ELEKTR. ANLAGE, SCHILDTRAEGER, HUBE SCHEINWI- HALTER (TE-SMR)	INSTALAC. ELECT., PORTA-MATRICULA CASQUETE PORTAFARO (TE-SMR)	107
26	INDICATORI DI DIREZIONE, AVVISATORE ACUSTICO (TE-SMR)	BLINKERS, HORN (TE-SMR)	CLIGNOTANTS, SIGNAL ACOUSTIQUE (TE-SMR)	BLINKERS, HUPE (TE-SMR)	INTERMITENTES, AVISADOR ACUSTICO (TE-SMR)	111
27	KIT TRASFORMAZIONE ENDURO (TE U.S.A.)	ENDURO TRANSFORMATION KIT (TE U.S.A.)	SET TRANSFORMATION ENDURO (TE U.S.A.)	KIT TRANSFORMATION ENDURO (TE U.S.A.)	KIT TRANSFORMATION ENDURO (TE U.S.A.)	113
28	DECALCOMANIE (TE)	TRANSFER (TE)	DECALCOMANIE (TE)	ABZIEHBILD (TE)	CALCOMANIA (TE)	117
29	DECALCOMANIE (TE-USA)	TRANSFER (TE-USA)	DECALCOMANIE (TE-USA)	ABZIEHBILD (TE-USA)	CALCOMANIA (TE-USA)	119
30	DECALCOMANIE (SMR)	TRANSFER (SMR)	DECALCOMANIE (SMR)	ABZIEHBILD (SMR)	CALCOMANIA (SMR)	121
-	INDICE NUMERICO PROGRESSIVO	NUMERICAL INDEX	INDEX NUMERIQUE	NUMMERNVERZEICHNIS	ÍNDICE NUMÉRICO PROGRESÍVO	122

Tavola - Drawing - Table - Bild - Tabla

1

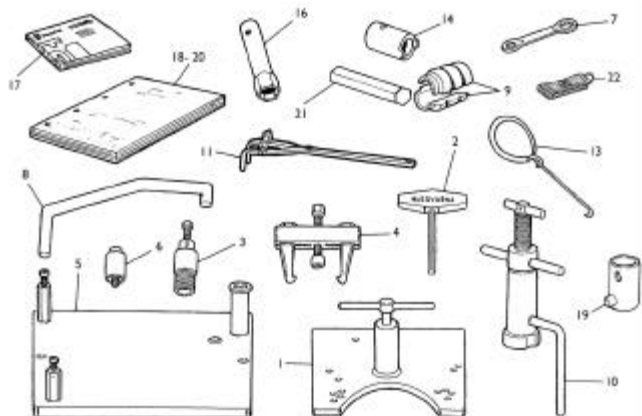

Pagina - Page - Page - Seite - Paja

11

Tavola - Drawing - Table - Bild - Tabla

2

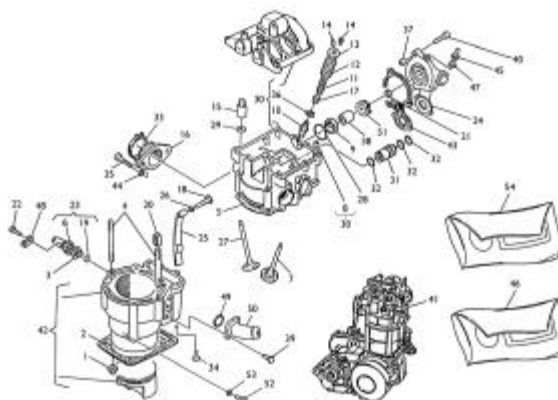

Pagina - Page - Page - Seite - Paja

15

Tavola - Drawing - Table - Bild - Tabla

3

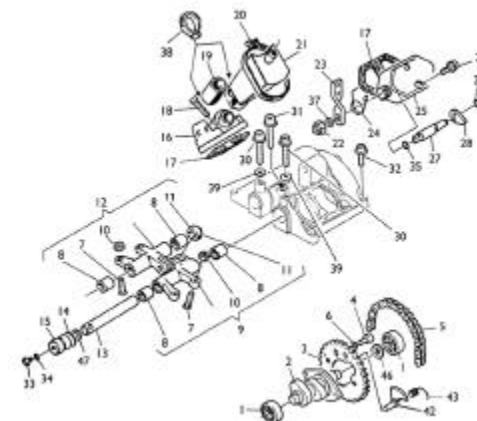

Pagina - Page - Page - Seite - Paja

19

Tavola - Drawing - Table - Bild - Tabla

4

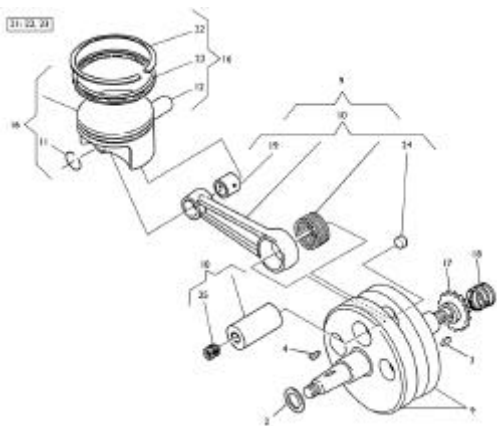

Pagina - Page - Page - Seite - Paja

23

Tavola - Drawing - Table - Bild - Tabla

5

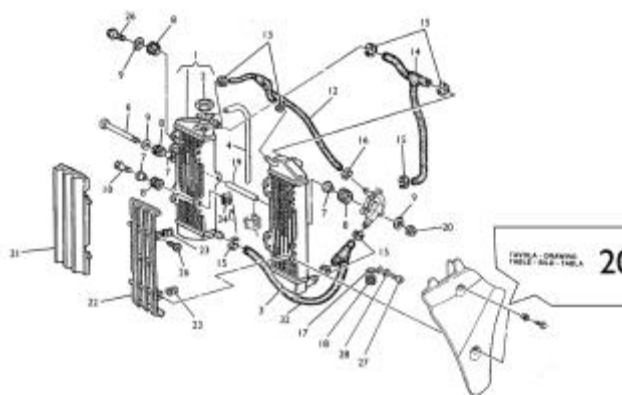

Pagina - Page - Page - Seite - Paja

25

Tavola - Drawing - Table - Bild - Tabla

6

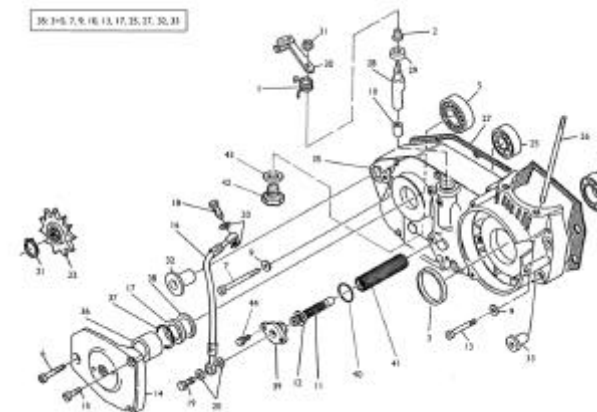

Pagina - Page - Page - Seite - Paja

27

Tavola - Drawing - Table - Bild - Tabla

7

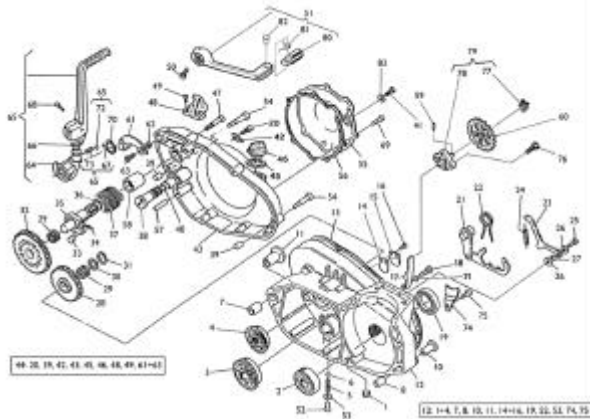

Pagina - Page - Page - Seite - Paja

31

Tavola - Drawing - Table - Bild - Tabla

8

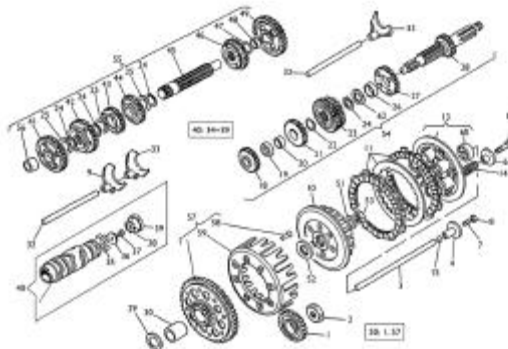

Pagina - Page - Page - Seite - Paja

37

Tavola - Drawing - Table - Bild - Tabla

9

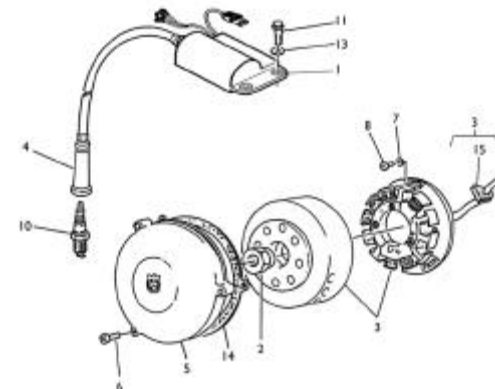

Pagina - Page - Page - Seite - Paja

43

Tavola - Drawing - Table - Bild - Tabla

10

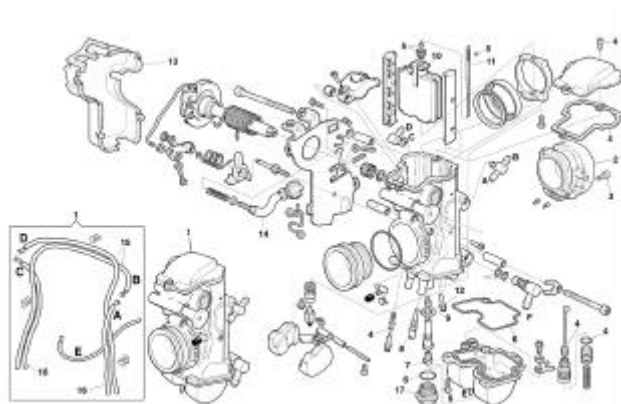

Pagina - Page - Page - Seite - Paja

45

Tavola - Drawing - Table - Bild - Tabla

11

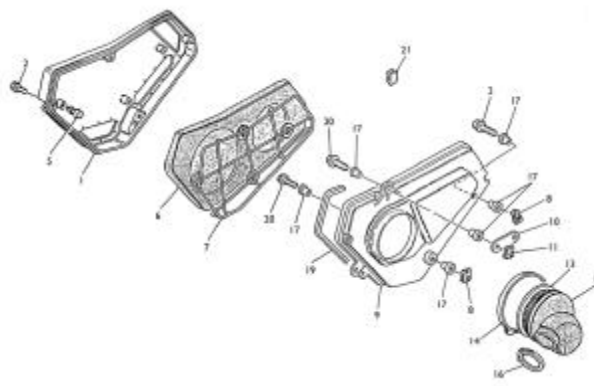

Pagina - Page - Page - Seite - Paja

49

Tavola - Drawing - Table - Bild - Tabla

12

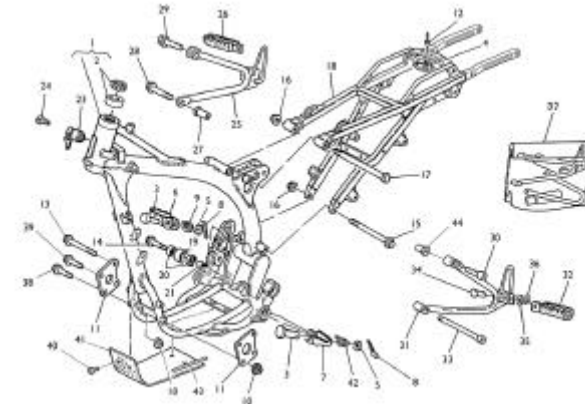

Pagina - Page - Page - Seite - Paja

51

Tavola - Drawing - Table - Bild - Tabla

13

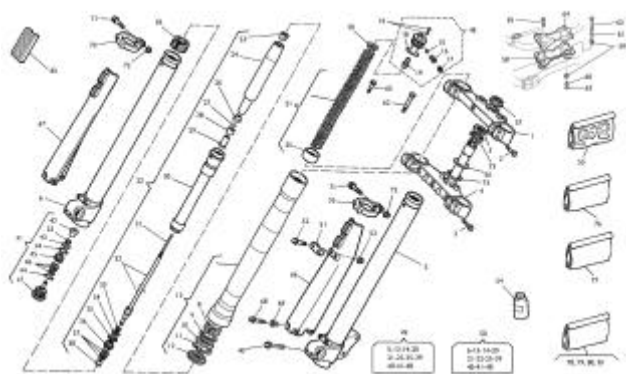

Pagina - Page - Page - Seite - Paja

55

Tavola - Drawing - Table - Bild - Tabla

14

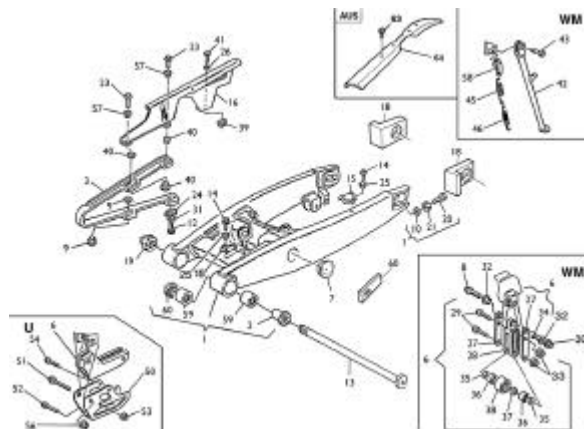

Pagina - Page - Page - Seite - Paja

63

Tavola - Drawing - Table - Bild - Tabla

15

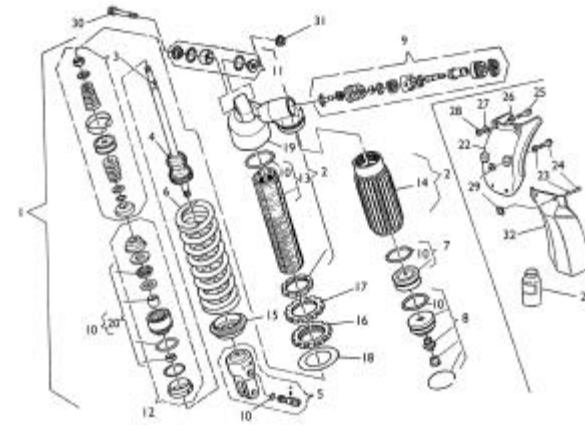

Pagina - Page - Page - Seite - Paja

67

Tavola - Drawing - Table - Bild - Tabla

16

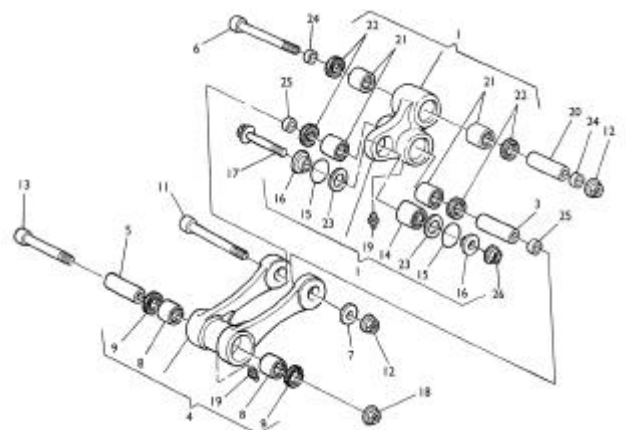

Pagina - Page - Page - Seite - Paja

71

Tavola - Drawing - Table - Bild - Tabla

17

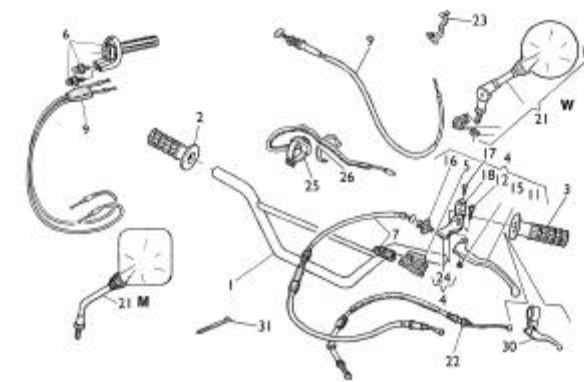

Pagina - Page - Page - Seite - Paja

73

Tavola - Drawing - Table - Bild - Tabla

18

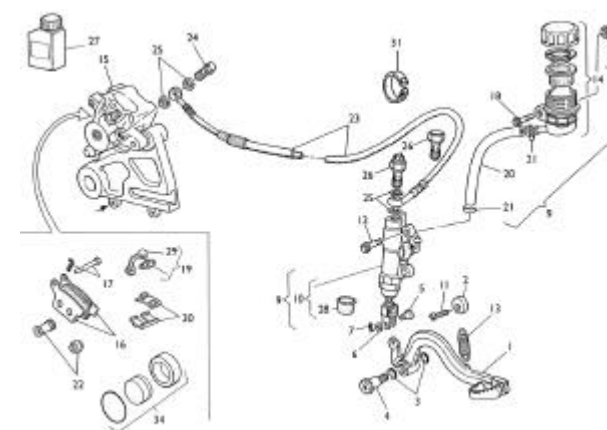

Pagina - Page - Page - Seite - Paja

77

Tavola - Drawing - Table - Bild - Tabla

19

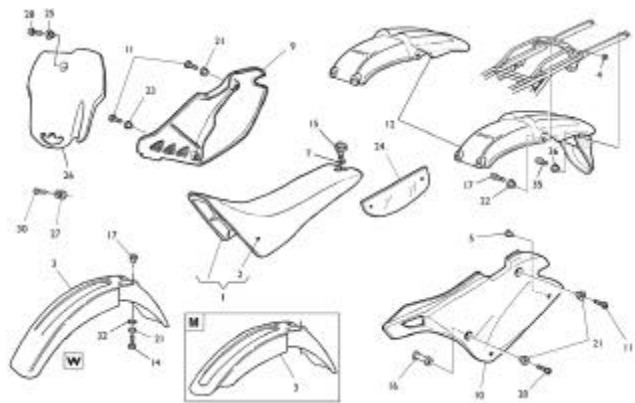

Pagina - Page - Page - Seite - Paja

81

Tavola - Drawing - Table - Bild - Tabla

20

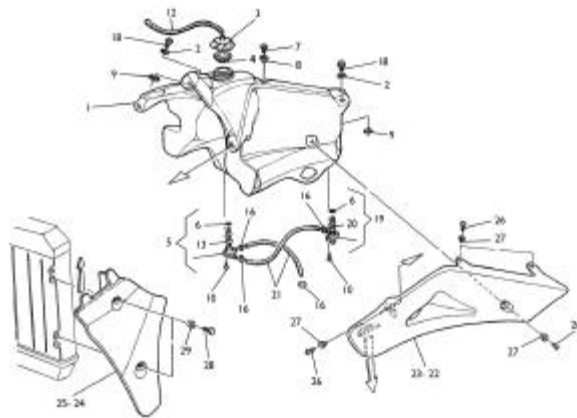

Pagina - Page - Page - Seite - Paja

85

Tavola - Drawing - Table - Bild - Tabla

21

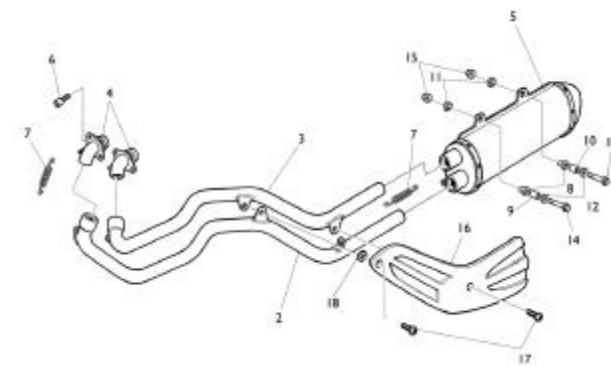

Pagina - Page - Page - Seite - Paja

87

Tavola - Drawing - Table - Bild - Tabla

22

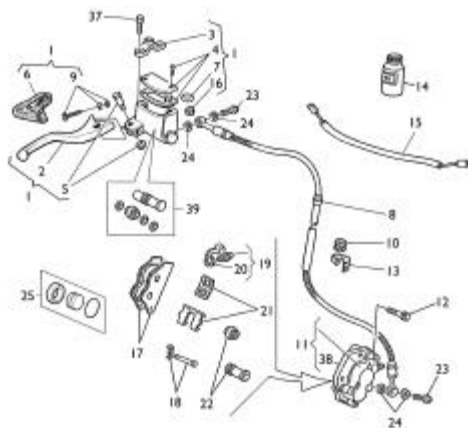

Pagina - Page - Page - Seite - Paja

89

Tavola - Drawing - Table - Bild - Tabla

22A

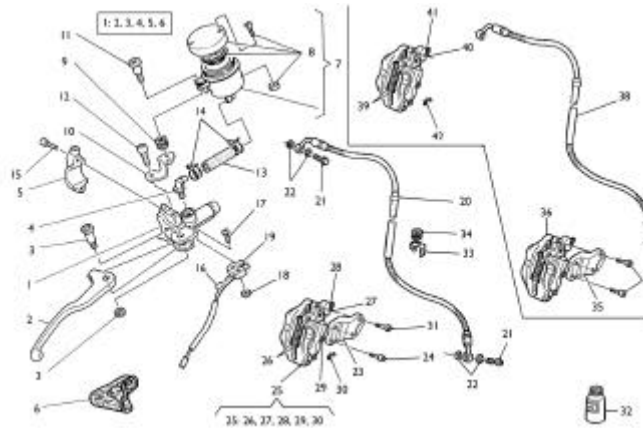

Pagina - Page - Page - Seite - Paja

93

Tavola - Drawing - Table - Bild - Tabla

22B

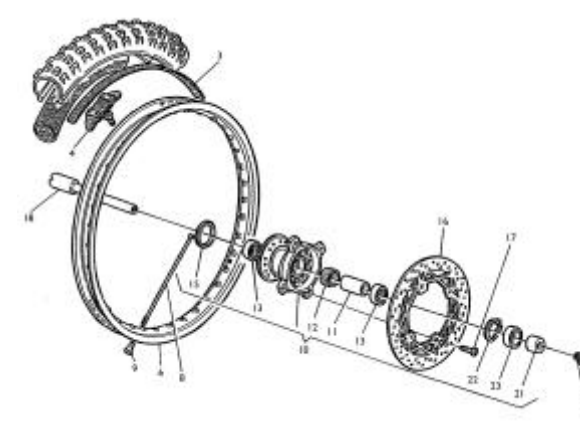

Pagina - Page - Page - Seite - Paja

97

Tavola - Drawing - Table - Bild - Tabla

22C

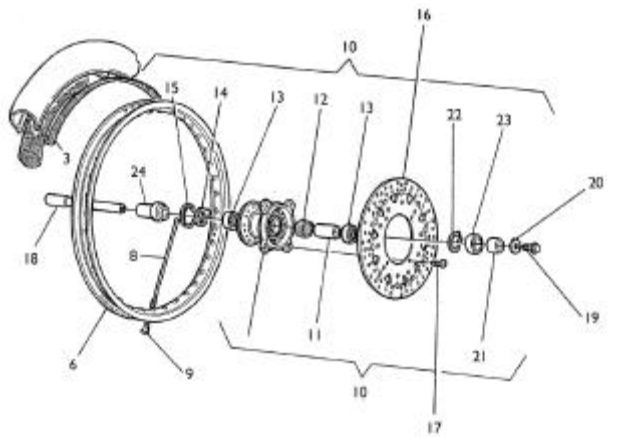

Pagina - Page - Page - Seite - Paja

99

Tavola - Drawing - Table - Bild - Tabla

23

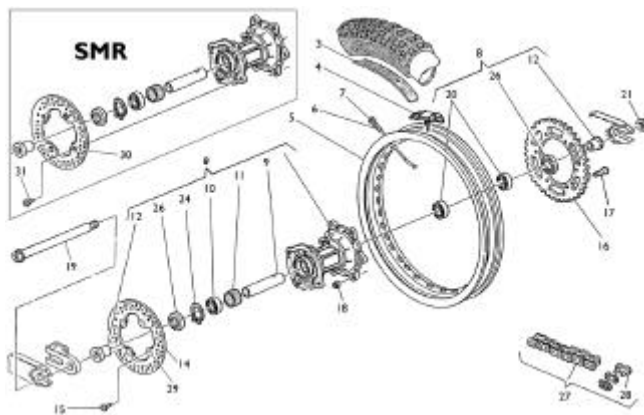

Pagina - Page - Page - Seite - Paja

101

Tavola - Drawing - Table - Bild - Tabla

24

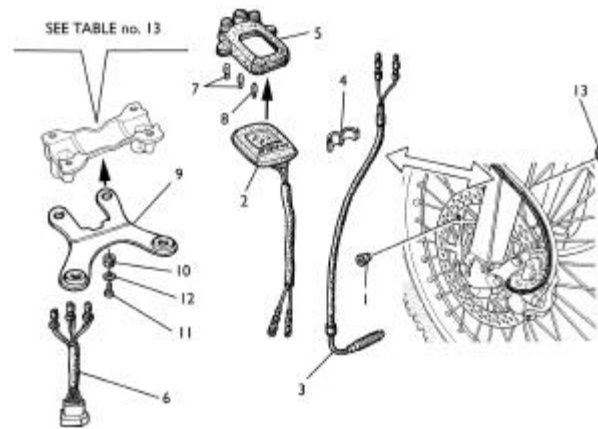

Pagina - Page - Page - Seite - Paja

105

Tavola - Drawing - Table - Bild - Tabla

25

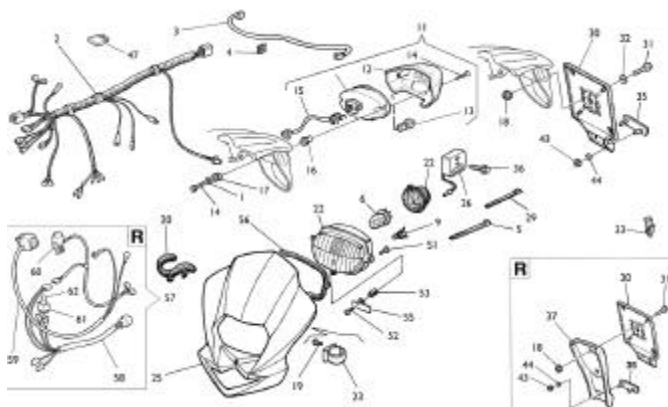

Pagina - Page - Page - Seite - Paja

107

Tavola - Drawing - Table - Bild - Tabla

26

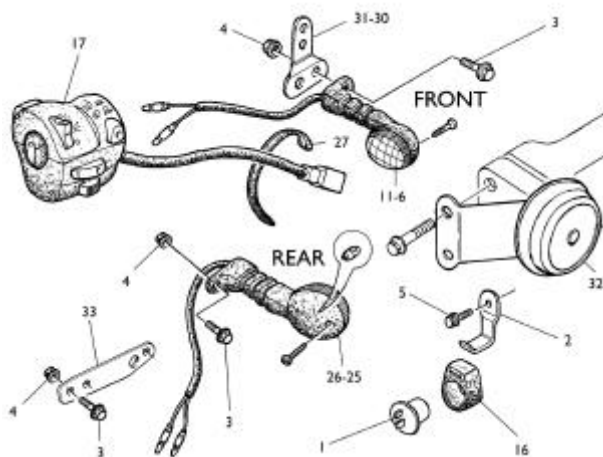

Pagina - Page - Page - Seite - Paja

111

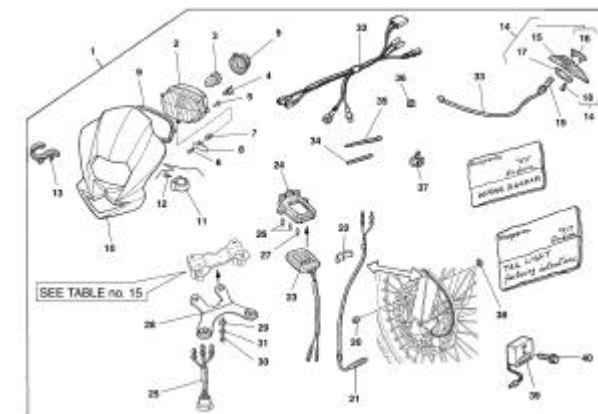

Tavola - Drawing - Table - Bild - Tabla

27



Pagina - Page - Page - Seite - Paja

113

<p>Tavola - Drawing - Table - Bild - Tabla</p> <p style="text-align: right;">28</p>  <p>Pagina - Page - Page - Seite - Paja</p> <p style="text-align: right;">117</p>	<p>Tavola - Drawing - Table - Bild - Tabla</p> <p style="text-align: right;">29</p>  <p>Pagina - Page - Page - Seite - Paja</p> <p style="text-align: right;">119</p>	<p>Tavola - Drawing - Table - Bild - Tabla</p> <p style="text-align: right;">30</p>  <p>Pagina - Page - Page - Seite - Paja</p> <p style="text-align: right;">121</p>

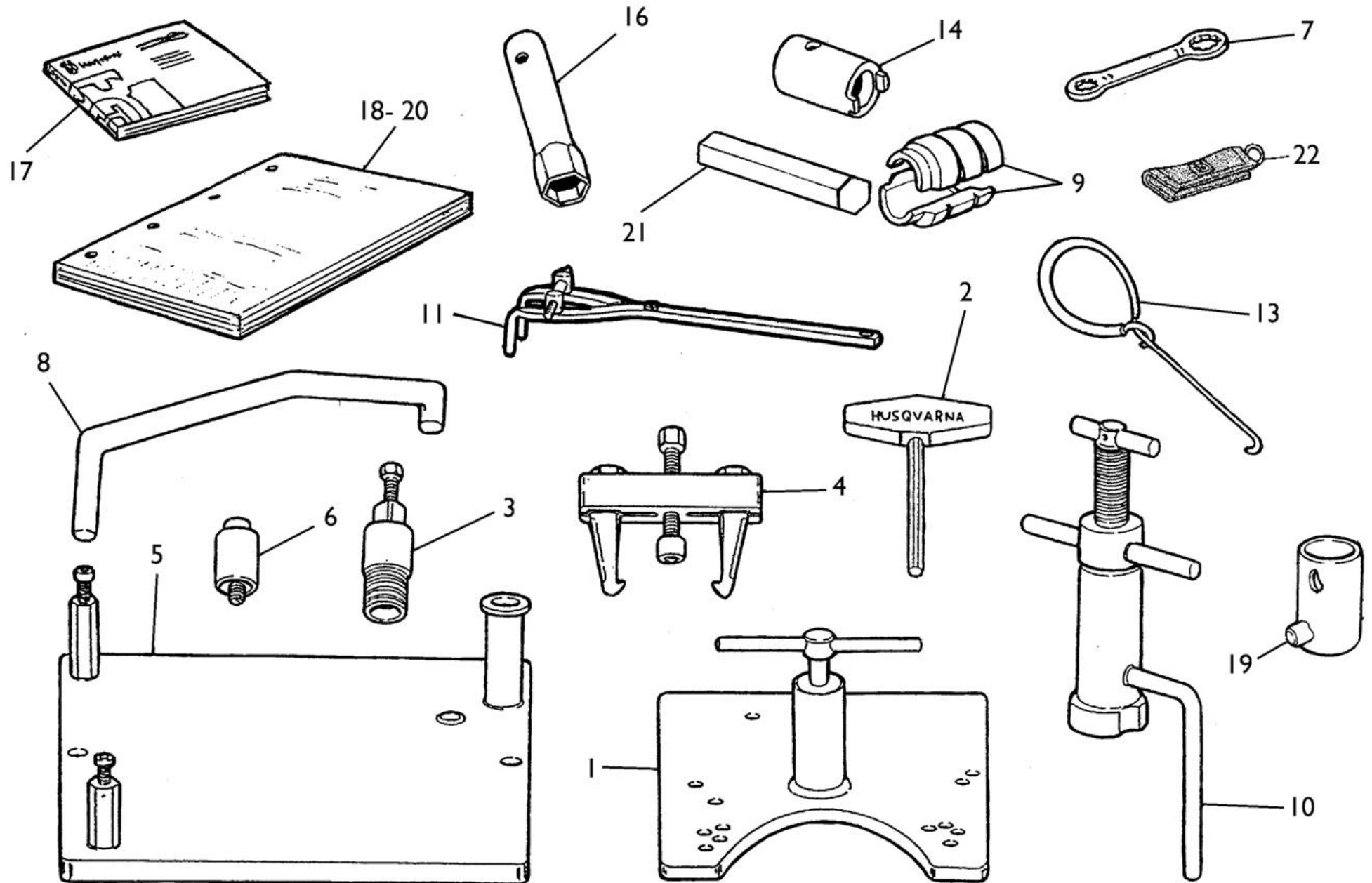



TE 570-
SM 570 R/ 2003

TAVOLA
DRAWING
TABLE
BILD
TABLA

I

ATTREZZI DI ASSISTENZA, MANUALI E CATALOGHI - SERVICE TOOLS, MANUALS AND CATALOGS
OUTILS D'ASSISTANCE, MANUELS ET CATALOGUES - HILFAUSRUSTUNG, HANDBUCH UND KATALOG
- HERRAMIENTAS DE ASISTENCIA, MANUALES Y CATALOGOS

Note Notes Markte Notas	Pos. No. N. Index Pos.	N. Cod. Code No. Nr. Code Code Nr N. Cod.	Q.tà Q.ty Q.te M.ge C.ad	DENOMINAZIONE	NAME	DESIGNATION	BESHREIBUNG	DENOMINACION	Validità Validity Validité Gültig Validez
	1	1517 94701	1	Estrattore basamento	Crankcase puller	Extracteur carter	Kurbelgehäuse-Auszieher	Extractor cárter	
	2	1519 65301	1	Chiave per esagono incassato	Allen wrench	Clé hexagonale	Sechskanteinsteckschlüssel	Llave de Allen	
	3	1615 13302	1	Estrattore volano	Flywheel extractor	Extracteur pour volant	Auszieher für Schwungrad	Extractor volante	
	4	1519 80501	1	Estratt. ingranaggio lato frizione	Clutch gear puller	Extract. engr. côté embrayage	Auszieher Kupplungszahnrads	Extr. engran. lado fricción	
	5	1515 59101	1	Supporto per montaggio	Support for assy	Support pour montage	Halterung für Montage	Soporte por el montaje	
	6	1514 13401	1	Estrattore braccio oscillante	Swing arm puller	Extract. bras oscillant	Schwingarm-Abzieher	Extractor brazo oscilante	
D	7	8000 66802	1	Chiave poligonale	Poligonal wrench	Cléf polygonale	Sechskantschlüssel	Llave poligonal	
	8	1517 94902	1	Attrezzo per volano	Tool for flywheel	Outil pour volant	Vorrichtung für Schwungrad	Herramienta para volante	
	9	8000 91288	1	Introduttore MIM	Jaw	Machoire	Zusatzbacke	Tenaza	
	10	8000 70637	1	Attrezzo mont. albero motore nel carter sinistro	Installing tool. crankshaft left	Outil pour montage vilebrequin dans le demicarter G.	Werkzeug für Montage der Kurbelwelle im L. Gehäuse	Herramienta mont. eje motor en el carter izq.	
	11	8000 79015	1	Chiave di fermo mozzo frizione	Clutch hub retaining wrench	Cléf d'arret moyeau embrayage	Halterungsschlüssel der Kupplungsnahe	Llave bloquear cubo fricción	

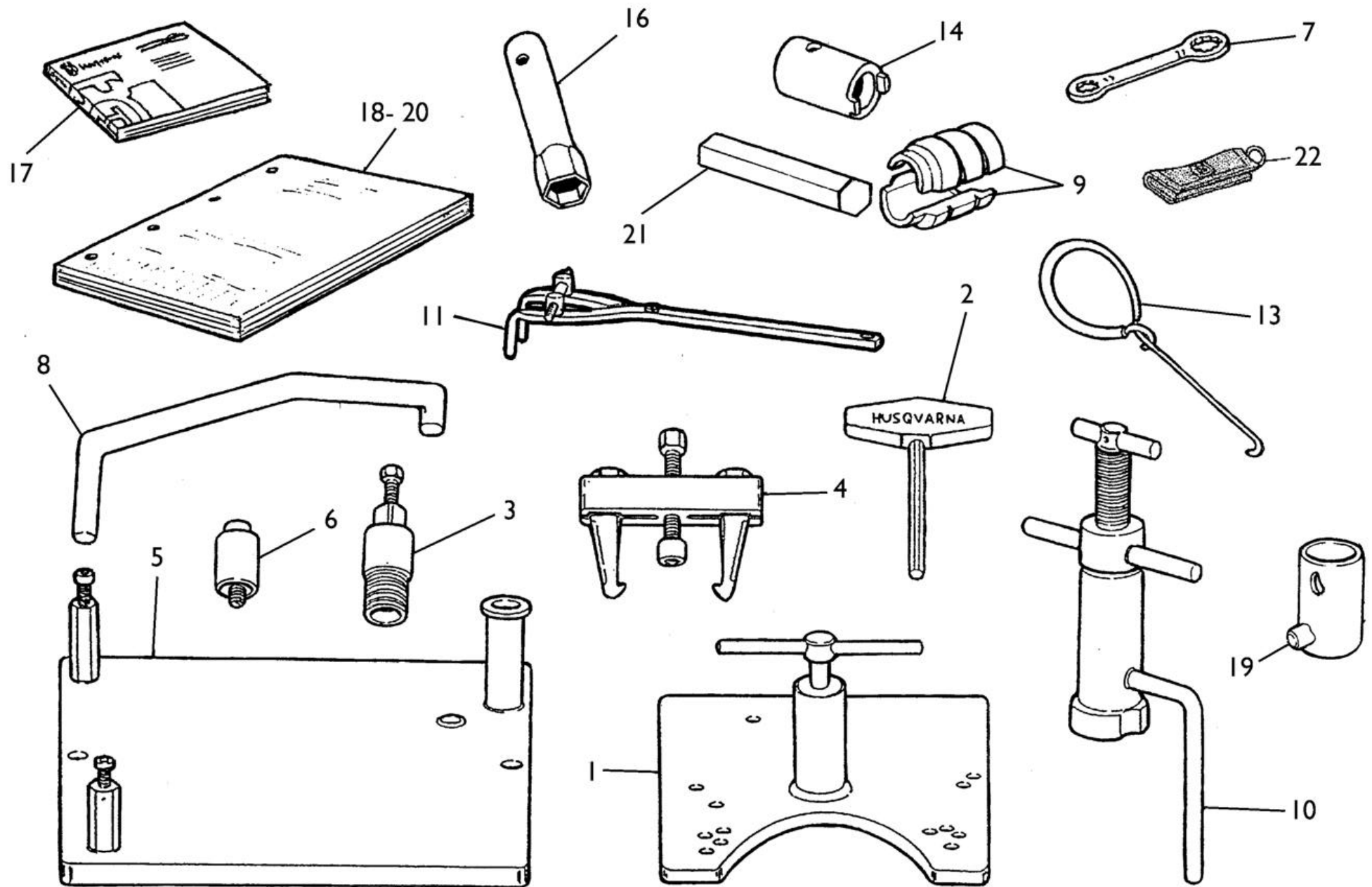

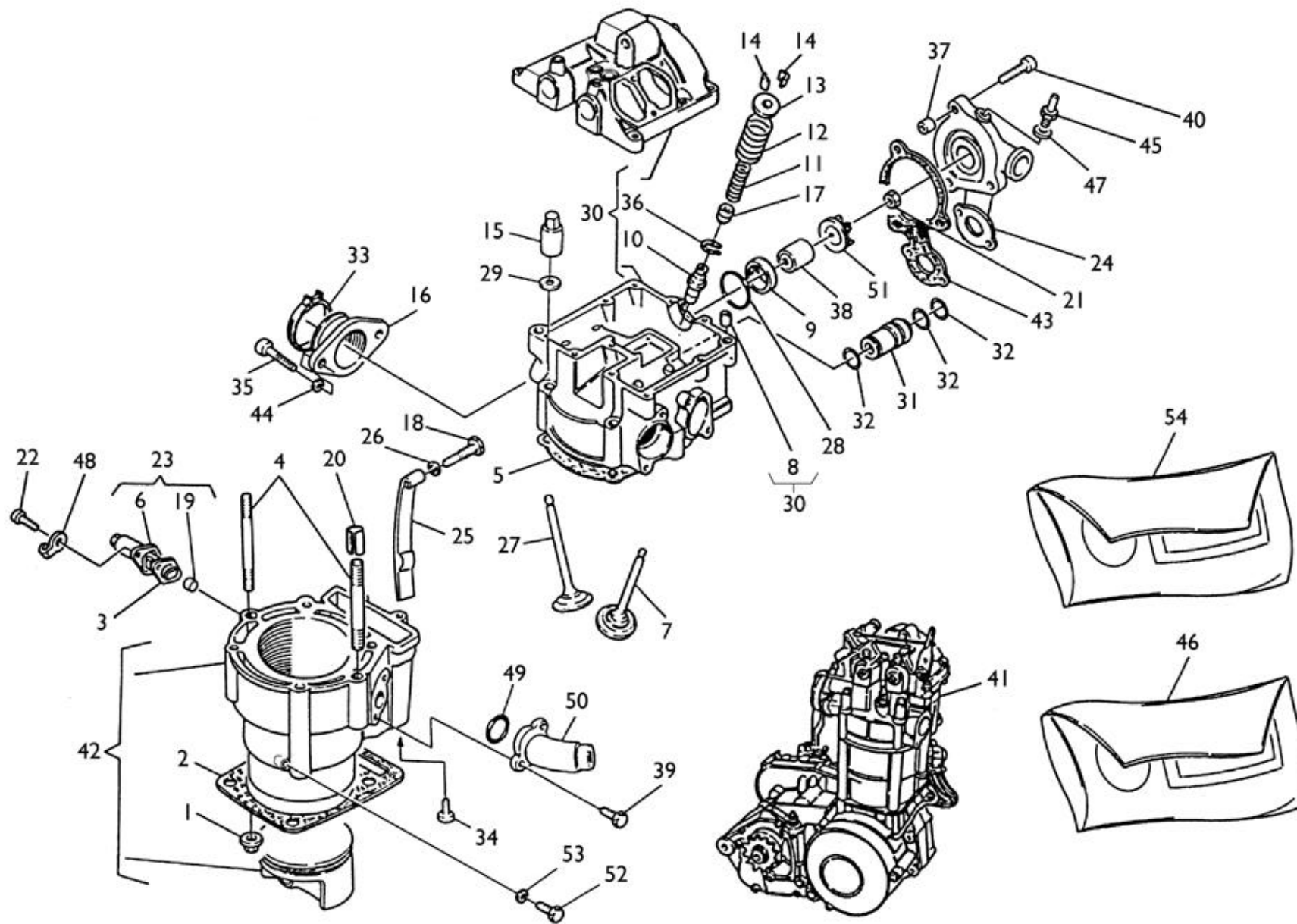

Note Notes Marke Notas	Pos. No. N. Index Pos.	N. Cod. Code No. Nr. Code Code Nr N. Cod.	Q.tà Q.ty Q.te M.ge C.ad	DENOMINAZIONE	NAME	DESIGNATION	BESHREIBUNG	DENOMINACION	Validità Validity Validité Gültig Validez
	1	61N1 15195	2	Dado	Nut	Ecrou	Mutter	Tuerca	
	2	1615 40702	1	Guarnizione	Gasket	Garnitue	Dichtung	Junta	
	3	1615 35801	1	Guarnizione	Gasket	Garnitue	Dichtung	Junta	
	4	1615 33201	2	Prigioniero	Stud bolt	Prisonnier	Stiftschraube	Prisionero	
	5	8000 64726	1	Guarnizione	Gasket	Garnitue	Dichtung	Junta	
	6	8000 67744	1	Tenditore	Tensioner	Tendeur	Zylinderspanner	Tensor	
	7	8000 66428	2	Valvola scarico	Exhaust valve	Soupape d'échappement	Auslass-Ventil	Válvula de escape	
	8	1611 70801	2	Bussola	Bushing	Douille	Buchse	Manguito	
	9	8000 63817	1	Bussola	Bushing	Douille	Buchse	Manguito	
	10	1615 29401	4	Guidavalvola	Valve guide	Guide-soupape	Ventilführung	Guía-válvula	
	11	1615 28801	4	Molla interna	Spring	Ressort	Feder	Resorte	
	12	1615 02501	4	Molla esterna	Spring	Ressort	Feder	Resorte	
	13	1615 29601	4	Scodellino	Cup	Cuvette	Teller	Cubeta	
	14	1615 02301	8	Semicono	Half cone	Demi-cône	Halb Kegel	Semi-cono	
	15	1615 35101	4	Dado	Nut	Ecrou	Mutter	Tuerca	
	16	8000 98205	1	Raccordo	Union	Raccord	Anschluss	Empalme	
	17	1615 30301	4	Anello di tenuta	Seal ring	Bague d'étanchéité	Dichtungsring	Anillo de retención	
A	17	8000 75584	4	Anello di tenuta	Seal ring	Bague d'étanchéité	Dichtungsring	Anillo de retención	
	18	1615 35902	1	Vite	Screw	Vis	Schraube	Tornillo	
	19	8000 68905	1	Distanziale	Spacer	Entretoise	Distanzstück	Separador	
	20	8000 47708	2	Spina elastica	Pin	Goupille	Stift	Clavija	
	21	8000 42278	1	Dado	Nut	Ecrou	Mutter	Tuerca	
	22	60N1 07335	2	Vite	Screw	Vis	Schraube	Tornillo	
	23	8000 68908	1	Tenditore completo	Complete tensioner	Tendeur complet	Zylinderspanner	Tensor completo	
	24	80C0 75766	1	Corpo pompa	Pump body	Corps pompe	Pumpenkörper	Corpo bomba	
	25	8000 66807	1	Pattino catena	Chain slider	Glissière	Gleitbahn	Plato cadena	
	26	8000 45194	1	Rosetta piana	Washer	Rondelle	Scheibe	Arandela	
	27	8000 66427	2	Valvola aspirazione	Inlet valve	Soupape admission	Einlass-Ventil	Válvula aspiración	
	28	8000 59942	1	Anello OR	O-Ring	Bague OR	O-Ring	Anillo OR	
	29	8000 69156	4	Rosetta piana	Washer	Rondelle	Scheibe	Arandela	
	30	8B00 78437	1	Coperchio e testa	Cover and head	Couvercle et culasse	Dekel und Zylinderkopf	Tapa e culata	

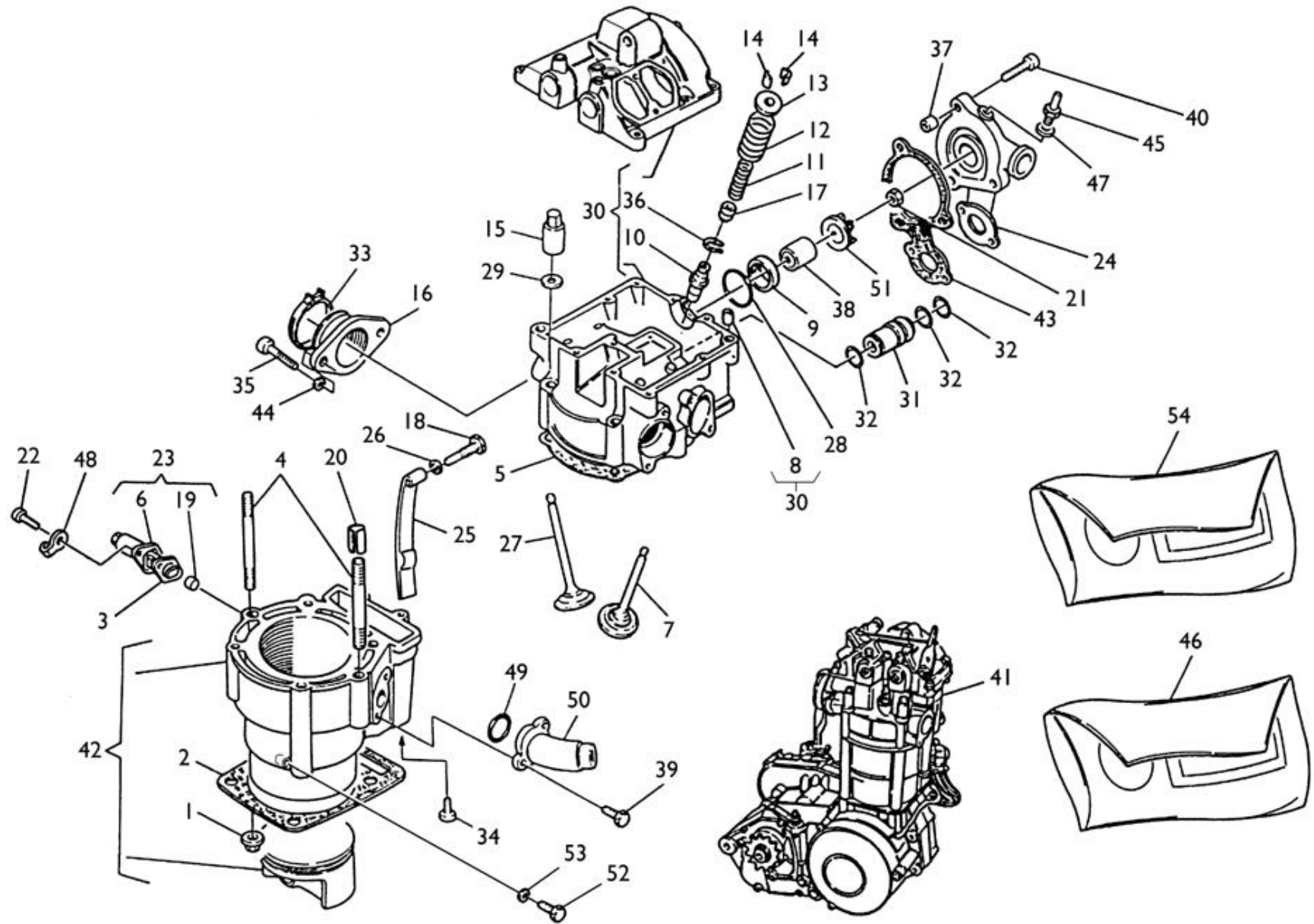

Note Notes Notas	Pos. No. Index Pos.	N. Cod. Code No. Nr. Code Code Nr N. Cod.	Q.tà Q.ty Q.te M.ge C.ad	DENOMINAZIONE	NAME	DESIGNATION	BESHREIBUNG	DENOMINACION	Validità Validity Validité Gültig Validez
	31	8A00 78765	1	Tubetto	Pipe	Tuyau	Rohr	Tubo	
	32	8000 18422	3	Anello OR	O-Ring	Bague OR	O-Ring	Anillo OR	
	33	8000 98290	1	Fascetta	Clamp	Collier	Schelle	Banda	
	34	60NI 02511	2	Vite (M6x30 mm)	Screw (M6x30 mm)	Vis (M6x30 mm)	Schraube (M6x30 mm)	Tornillo (M6x30 mm)	
	35	60NI 02557	2	Vite	Screw	Vis	Schraube	Tornillo	
	36	8000 59940	4	Anello di arresto	Snap ring	Bague d'arrêt	Haltering	Anillo elástico de retención	
	37	1617 95501	2	Bussola	Bushing	Douille	Buchse	Manguito	
	38	8000 53339	1	Anello di tenuta	Seal ring	Bague d'étanchéité	Dichtungsring	Anillo de retención	
	39	8000 62727	2	Vite	Screw	Vis	Schraube	Tornillo	
	40	8000 62730	5	Vite	Screw	Vis	Schraube	Tornillo	
	41	8000 A1718	1	Assieme motore	Engine assy	Moteur complet	Motor kpl.	Motor compl.	
	41	8000 A0136	1	Assieme motore (USA)	Engine assy (USA)	Moteur complet (USA)	Motor kpl. (USA)	Motor compl. (USA)	
	42	8000 89910	1	Cilindro completo (gilardoni)	Cylinder assy (gilardoni)	Cylindre compl. (gilardoni)	Zylinder kpl. (gilardoni)	Cilindro compl. (gilardoni)	
A	42	8000 A1723	1	Cilindro completo (gilardoni)	Cylinder assy (gilardoni)	Cylindre compl. (gilardoni)	Zylinder kpl. (gilardoni)	Cilindro compl. (gilardoni)	
A	42	8000 A2715	1	Cilindro completo (tecnol)	Cylinder assy (tecnol)	Cylindre compl. (tecnol)	Zylinder kpl. (tecnol)	Cilindro compl. (tecnol)	
A	42	8000 A2716	1	Cilindro completo (tecnol)	Cylinder assy (tecnol)	Cylindre compl. (tecnol)	Zylinder kpl. (tecnol)	Cilindro compl. (tecnol)	
	43	8A00 63644	1	Guarnizione	Gasket	Garnitue	Dichtung	Junta	
	44	8000 08536	2	Rosetta piana	Washer	Rondelle	Scheibe	Arandela	
	45	8000 66395	1	Raccordo	Union	Raccord	Anschluss	Empalme	
R	46	8000 96880	1	Gruppo guarnizioni motore	Gasket set	Groupe garnitures	Dichtungssatz	Grupo juntas	
	47	8A00 15960	1	Rosetta	Washer	Rondelle	Scheibe	Arandela	
	48	8000 24319	1	Piastrina	Plate	Plaquette	Plättchen	Placa	
	49	8000 19789	1	Anello OR	O-Ring	Bague OR	O-Ring	Anillo OR	
	50	80A0 66222	1	Raccordo	Union	Raccord	Anschluss	Empalme	
	51	8A00 60415	1	Girante	Rotor	Couronne	Laufgrad	Rotor	
	52	8000 62725	1	Vite	Screw	Vis	Schraube	Tornillo	
	53	8A00 15960	1	Rosetta	Washer	Rondelle	Scheibe	Arandela	
R	54	8000 96881	1	Gruppo anelli di tenuta motore	Engine seal ring set	Groupe bague moteur	Dichtungsringgruppe Motor	Grupo anillos	

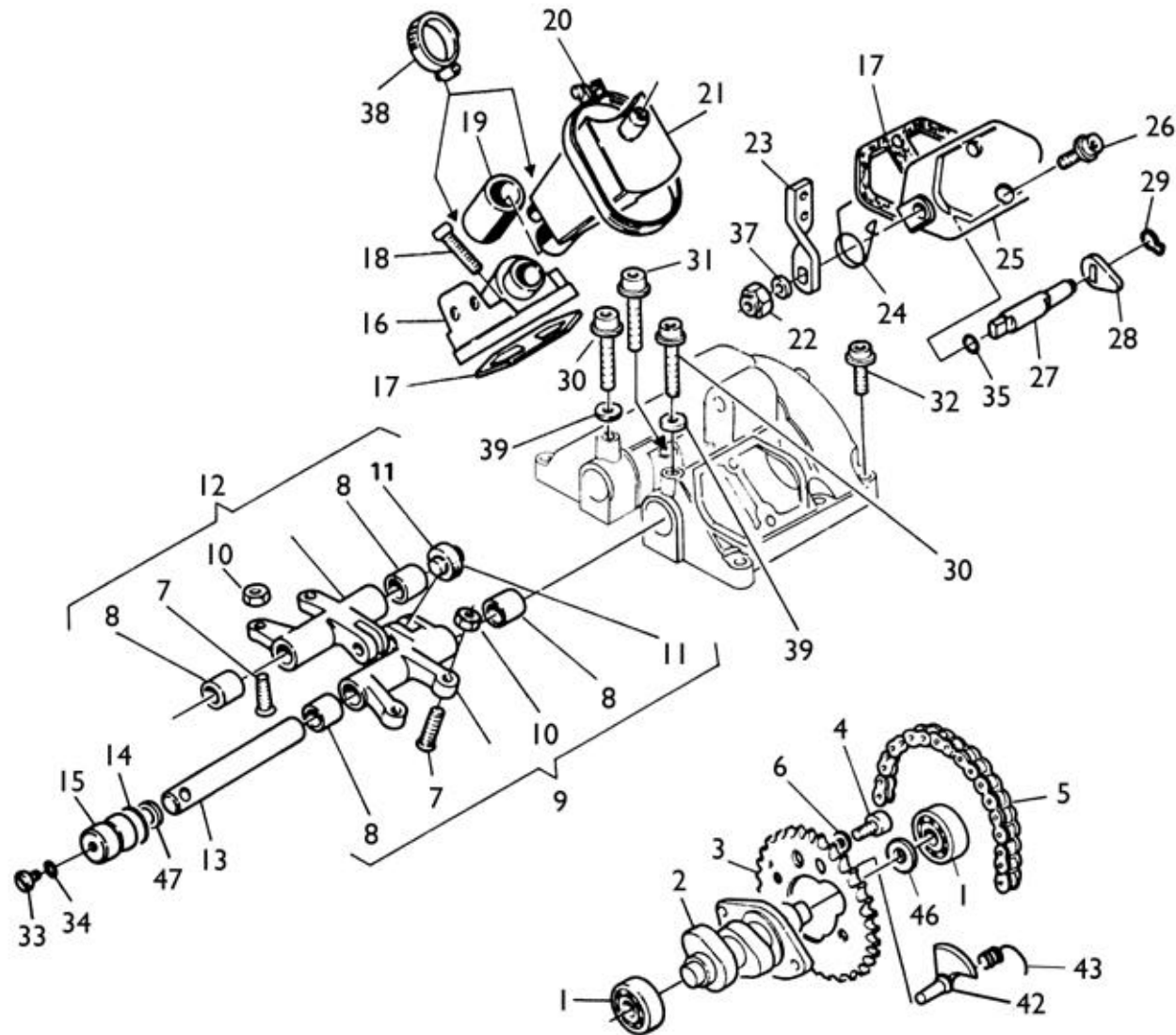

Note Notes Notas	Pos. No. Index Pos.	N. Cod. Code No. Nr. Code Code Nr N. Cod.	Q.tà Q.ty Q.te M.ge C.ad	DENOMINAZIONE	NAME	DESIGNATION	BESHREIBUNG	DENOMINACION	Validità Validity Validité Gültig Validez
	1	8000 02124	2	Cuscinetto (ø12xø32x10 mm)	Bearing (ø12xø32x10 mm)	Roulement (ø12xø32x10 mm)	Lager (ø12xø32x10 mm)	Cojinete (ø12xø32x10 mm)	
	2	8000 73150	1	Albero a camme	Camshaft	Arbre distribution	Nockenwelle	Eje distribución	
	3	8000 71028	1	Ingranaggio condotto	Driven gear	Engranaage conduit	Zahnrad	Engranaje conducto	
	4	1615 26602	2	Vite	Screw	Vis	Schraube	Tornillo	
	5	8A00 35794	1	Catena distribuzione	Chain	Chaîne	Kette	Cadena	
	6	62NI 15658	2	Rosetta elastica	Spring washer	Rondelle élastique	Federscheibe	Arandela elástica	
	7	1615 04901	4	Vite di registro	Adjusting screw	Vis de réglage	Verstellungsschraube	Tornillo de regulación	
	8	1615 04301	4	Bussola	Bushing	Douille	Buchse	Manguito	
	9	1615 09601	1	Bilancere di scarico completo	Exhaust rocker-arm assy	Culbuteur échappem. compl.	Kipphebel Auspuffrohr kpl.	Balancín de escape compl.	
	10	1615 15601	4	Dado	Nut	Ecrou	Mutter	Tuerca	
	11	1615 04501	2	Cuscinetto a rullini	Needle bearing	Roulement à aiguilles	Nadelkäfig	Cojinete de rodillos	
	12	1615 09501	1	Bilancere di aspirazione compl.	Inlet rocker-arm assy	Culbuteur d'aspiration compl.	Kipphebel Ansaugen kpl.	Balancín de aspiración compl.	
	13	1615 04201	2	Perno	Pin	Pivot	Bolzen	Perno	
	14	8000 59939	2	Anello OR	O-Ring	Bague OR	O-Ring	Anillo OR	
	15	1615 39301	2	Tappo	Plug	Bouchon	Verschluss	Tapón	
	16	80B0 84174	1	Coperchio registri	Cover	Couvercle	Deckel	Tapa	
	17	1615 03601	2	Guarnizione	Gasket	Garnitue	Dichtung	Junta	
	18	8000 62728	3	Vite (M6x20 mm)	Screw (M6x20 mm)	Vis (M6x20 mm)	Schraube (M6x20 mm)	Tornillo (M6x20 mm)	
	19	1615 14104	1	Tubetto	Tube	Tuyau	Rohr	Tubo	
	20	8000 37299	1	Fascetta	Clamp	Collier	Schelle	Banda	
	21	1615 12802	1	Contentore vapori basamento	Crankcase vapours cup	Cuve vapeurs carter	Dampfgefäß im Kurbelgehäuse	Contenedor vapores cárter	
	22	61NI 15195	1	Dado	Nut	Ecrou	Mutter	Tuerca	
	23	1615 40802	1	Leva	Lever	Levier	Hebel	Palanca	
	24	1615 12301	1	Molla	Spring	Ressort	Feder	Resorte	
	25	80B0 84173	1	Coperchio decompressore	Cover	Couvercle	Deckel	Tapa	
	26	8E00 67545	1	Vite (M6x40 mm)	Screw (M6x40 mm)	Vis (M6x40 mm)	Schraube (M6x40 mm)	Tornillo (M6x40 mm)	
	27	1615 08401	1	Perno	Pin	Pivot	Bolzen	Perno	
	28	1615 08501	1	Camma decompressore	Cam	Came	Nocken	Excéntrico	
	29	8000 21375	1	Anello di fermo	Stop ring	Bague d'arrêt	Haltering	Anillo de retención	
	30	8D00 67545	2	Vite (M6x60 mm)	Screw (M6x60 mm)	Vis (M6x60 mm)	Schraube (M6x60 mm)	Tornillo (M6x60 mm)	
A	30	8000 96796	2	Vite (M6x60 mm)	Screw (M6x60 mm)	Vis (M6x60 mm)	Schraube (M6x60 mm)	Tornillo (M6x60 mm)	
	31	8000 62731	1	Vite (M6x45 mm)	Screw (M6x45 mm)	Vis (M6x45 mm)	Schraube (M6x45 mm)	Tornillo (M6x45 mm)	

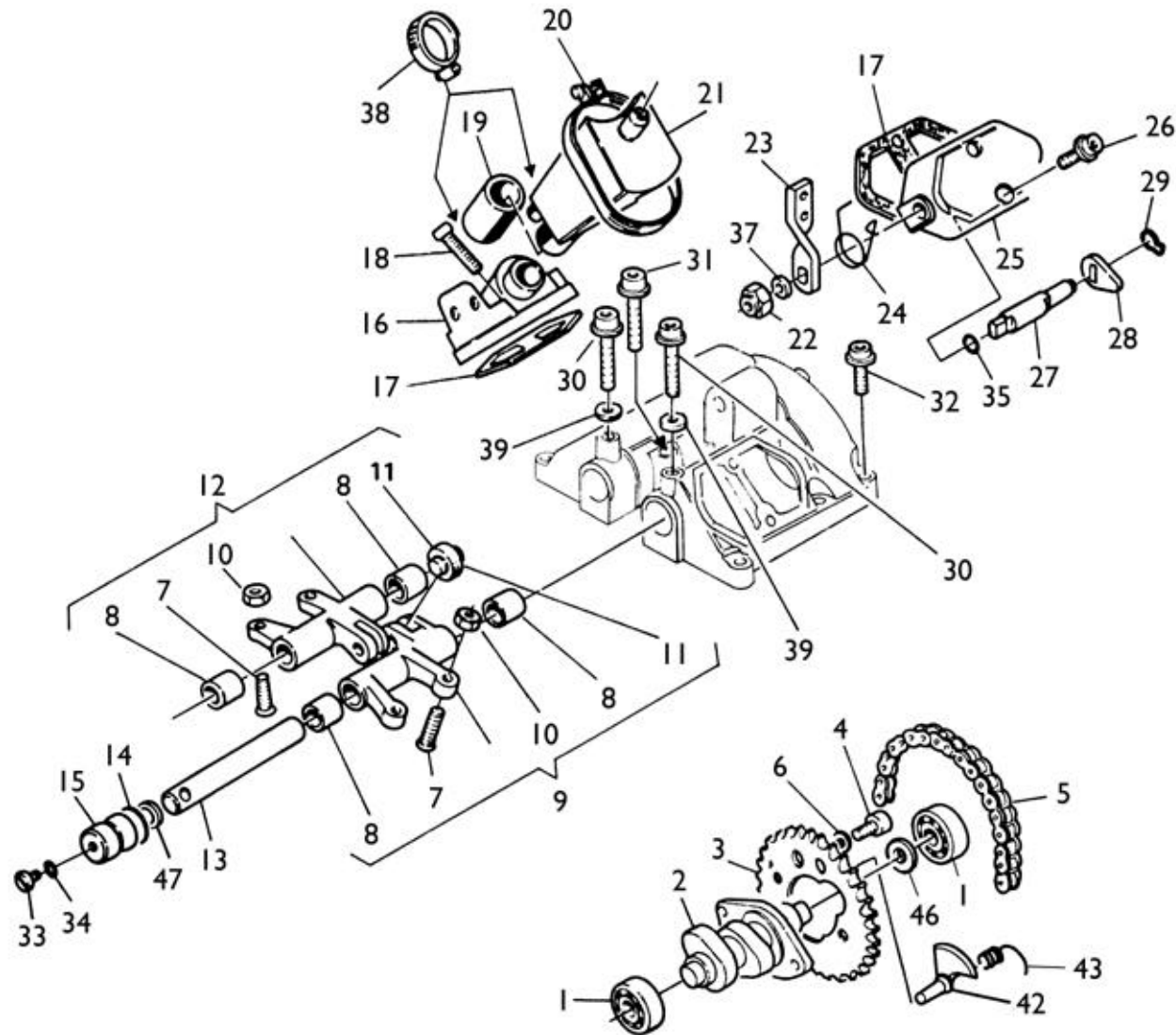

Note Notes Notas	Pos. No. Index Pos.	N. Cod. Code No. Nr. Code Code Nr N. Cod.	Q.tà Q.ty M.ge C.ad	DENOMINAZIONE	NAME	DESIGNATION	BESHREIBUNG	DENOMINACION	Validità Validity Validité Gültig Validez
	32	8000 62730	8	Vite (M6x30 mm)	Screw (M6x30 mm)	Vis (M6x30 mm)	Schraube (M6x30 mm)	Tornillo (M6x30 mm)	
	33	60NI 02927	2	Vite	Screw	Vis	Schraube	Tornillo	
	34	8A00 15960	2	Rosetta piana	Washer	Rondelle	Scheibe	Arandela	
	35	8000 59941	1	Anello OR	O-Ring	Bague OR	O-Ring	Anillo OR	
	37	62NI 15567	1	Rosetta piana	Washer	Rondelle	Scheibe	Arandela	
	38	8A00 99475	2	Fascetta	Clamp	Collier	Schelle	Banda	
	39	8000 64988	2	Rosetta	Washer	Rondelle	Scheibe	Arandela	
	42	8000 72289	1	Alzavalvola	Valve lifter	Levée de soupape	Ventil aufheber	Alza valvula	
	43	8000 72290	1	Molla	Spring	Ressort	Feder	Resorte	
	46	8F00 10789	1	Rosetta	Washer	Rondelle	Scheibe	Arandela	
	47	8000 50322	2	Rosetta di rasamento (0,3 mm)	Washer (0,3 mm)	Rondelle (0,3 mm)	Scheibe (0,3 mm)	Arandela (0,3 mm)	
	47	8A00 50322	2	Rosetta di rasamento (0,4 mm)	Washer (0,4 mm)	Rondelle (0,4 mm)	Scheibe (0,4 mm)	Arandela (0,4 mm)	
	47	8B00 50322	2	Rosetta di rasamento (0,5 mm)	Washer (0,5 mm)	Rondelle (0,5 mm)	Scheibe (0,5 mm)	Arandela (0,5 mm)	
	47	8C00 50322	2	Rosetta di rasamento (0,6 mm)	Washer (0,6 mm)	Rondelle (0,6 mm)	Scheibe (0,6 mm)	Arandela (0,6 mm)	

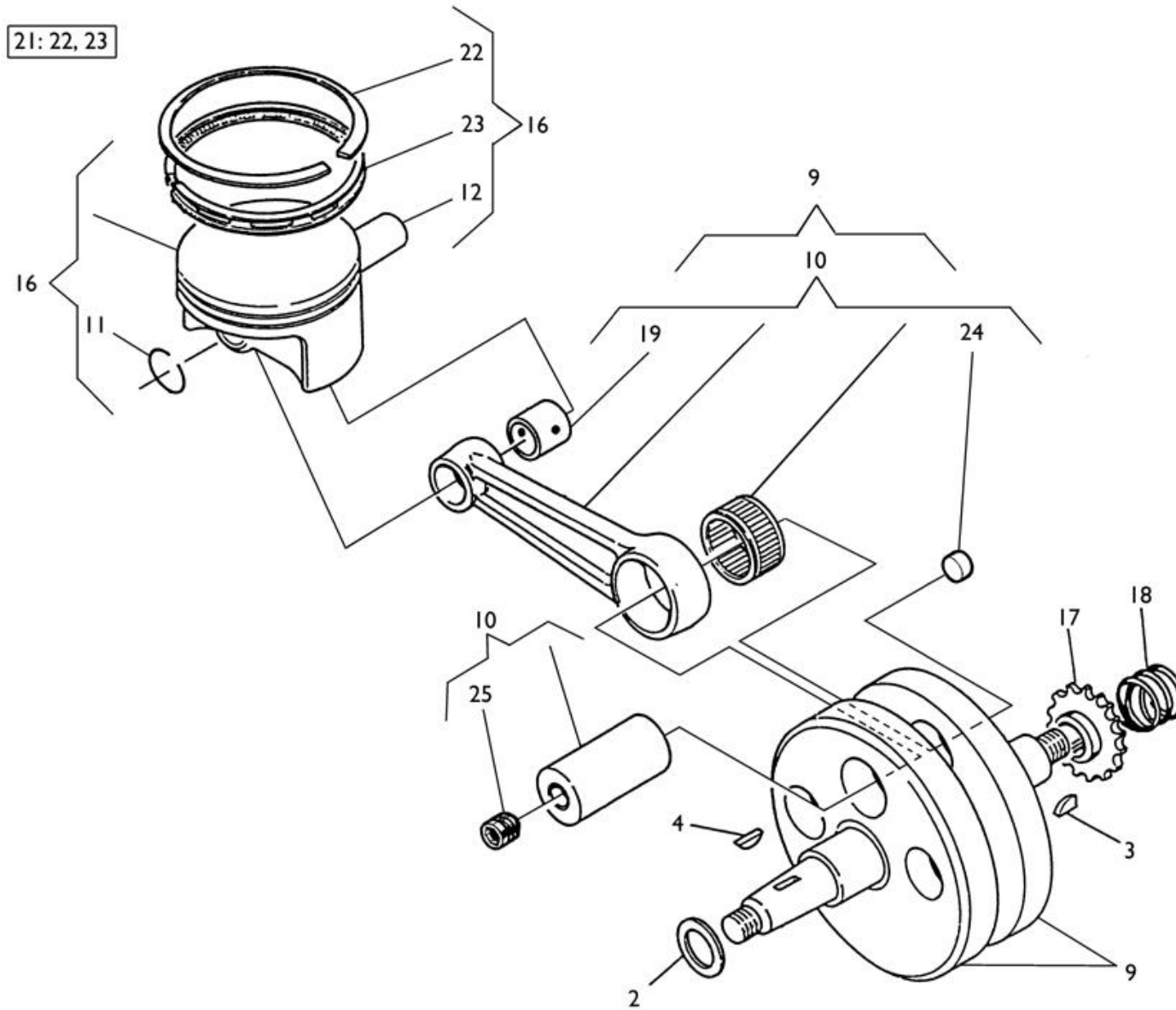

Note Notes Markes Notas	Pos. No. Index Pos.	N. Cod. Code No. Nr. Code Code Nr N. Cod.	Q.tà Q.ty Q.te M.ge C.ad	DENOMINAZIONE	NAME	DESIGNATION	BESHREIBUNG	DENOMINACION	Validità Validity Validité Gültig Validez
	2	8A00 28183	1	Rosetta di rasamento (0,3 mm)	Washer (0,3 mm)	Rondelle (0,3 mm)	Scheibe (0,3 mm)	Arandela (0,3 mm)	
	2	8C00 28183	1	Rosetta di rasamento (0,5 mm)	Washer (0,5 mm)	Rondelle (0,5 mm)	Scheibe (0,5 mm)	Arandela (0,5 mm)	
	2	8D00 28183	1	Rosetta di rasamento (0,6 mm)	Washer (0,6 mm)	Rondelle (0,6 mm)	Scheibe (0,6 mm)	Arandela (0,6 mm)	
	2	8F00 28183	1	Rosetta di rasamento (0,8 mm)	Washer (0,8 mm)	Rondelle (0,8 mm)	Scheibe (0,8 mm)	Arandela (0,8 mm)	
	2	8H00 28183	1	Rosetta di rasamento (1,0 mm)	Washer (1,0 mm)	Rondelle (1,0 mm)	Scheibe (1,0 mm)	Arandela (1,0 mm)	
	3	1615 09801	1	Linguetta	Woodruff key	Clé woodruff	Federkeil	Lengüeta	
	4	1513 71301	1	Linguetta	Woodruff key	Clé woodruff	Federkeil	Lengüeta	
	9	8000 96869	1	Albero motore completo	Crankshaft assy	Vilebrequin compl.	Kurbewelle kpl.	Cigüeñal compl.	
	10	8000 97986	1	Biella completa	Connecting rod compl.	Bielle compl.	Pleuelstange kpl.	Biela motor completa	
	11	8000 67824	2	Anello di fermo	Stop ring	Bague d'arrêt	Haltering	Anillo de retención	
	12	8000 71787	1	Spinotto	Gudgeon	Axe	Bolzen	Perno	
&	16	8000 89908	1	Pistone completo (Ø 98 mm)	Compl. piston (Ø 98 mm)	Piston complet (Ø 98 mm)	Kolben, kpl. (Ø 98 mm)	Pistón completo (Ø 98 mm)	
A@	16	8000 A1722	1	Pistone completo (Ø 98 mm)	Compl. piston (Ø 98 mm)	Piston complet (Ø 98 mm)	Kolben, kpl. (Ø 98 mm)	Pistón completo (Ø 98 mm)	
	17	8C00 71027	1	Ingranaggio distribuzione	Gear	Engranage	Zahnrad	Engranaje	
	18	8000 61275	1	Molla	Spring	Ressort	Feder	Resorte	
	19	8000 88073	1	Bussola	Bushing	Douille	Buchse	Manguito	
	21	8000 77715	1	Kit segmenti	Circlip kit	Kit segment	Kolbenring kit	Kit segmento	
	22	8000 67821	1	Segmento	Circlip	Ségment	Kolbenring	Segmento	
	23	8000 67822	1	Raschiaolio	Scraper ring	Ségment racleur huile	Ölabstreifring	Rascador aceite	
	24	8000 57196	1	Tappo	Plug	Bouchon	Verschluss	Tapòn	
	25	8A00 45395	1	Tappo filettato	Threaded plug	Bouchon fileté	Gewindepfropf	Tapòn filete	
	(&)			per cilindri 8000 89910 e 8000 A2715	use with cylinders 8000 89910 and 8000 A2715	avec cylindres 8000 89910 et 8000 A2715	mit Zylinder 8000 89910 und 8000 A2715	por cilindros 8000 89910 y 8000 A2715	
	(@)			per cilindri 8000 A1723 e 8000 A2716	use with cylinder 8000 A1723 and 8000 A2716	avec cylindres 8000 A1723 et 8000 A2716	mit Zylinder 8000 A1723 und 8000 A2716	por cilindros 8000 A1723 y 8000 A2716	

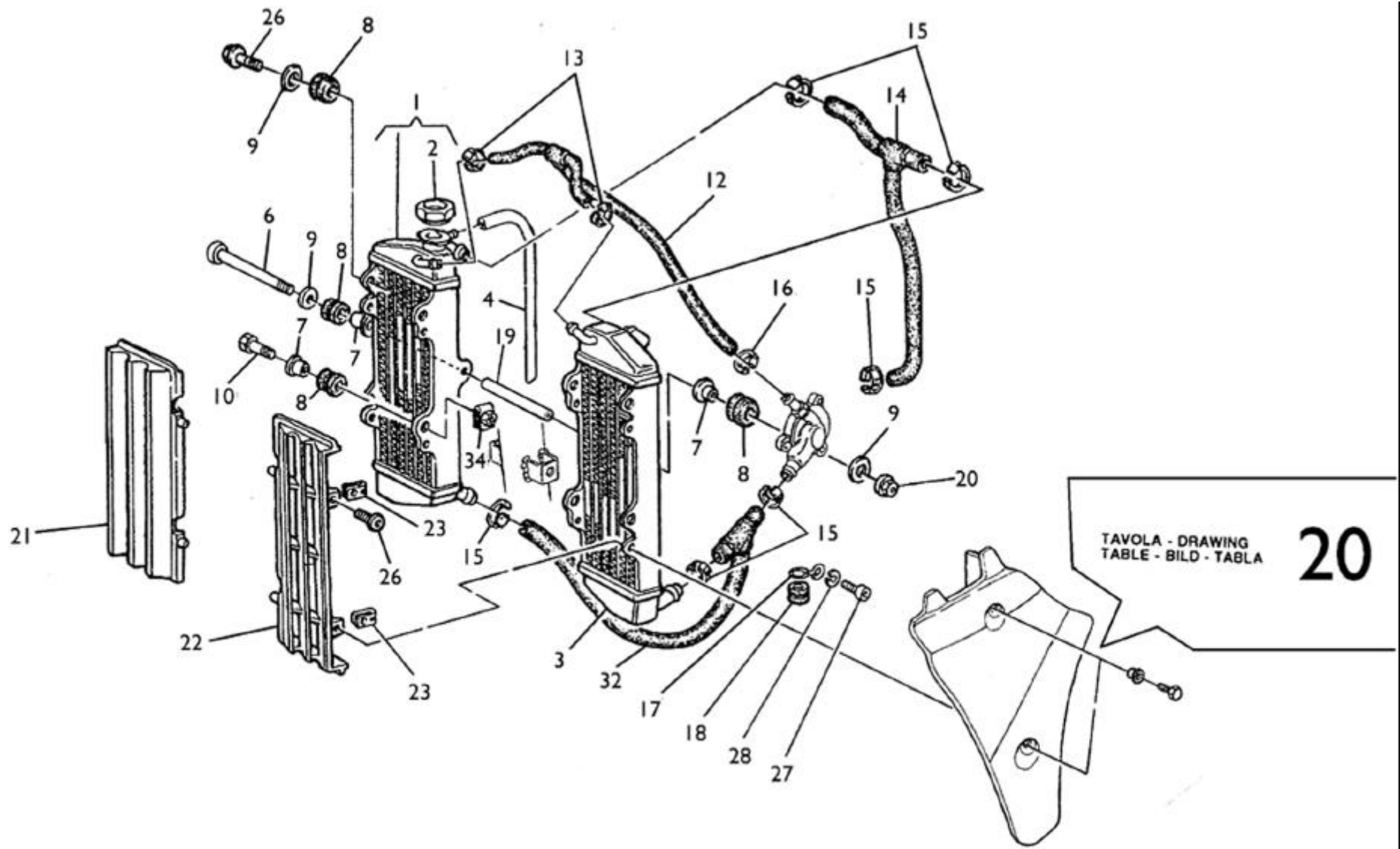

Note Notes Notas	Pos. No. Index Pos.	N. Cod. Code No. Nr. Code Code Nr N. Cod.	Q.tà Q.ty Q.te M.ge C.ad	DENOMINAZIONE	NAME	DESIGNATION	BESHREIBUNG	DENOMINACION	Validità Validity Validité Gültig Validez
	1	8000 87119	1	Radiatore Dx. completo	R.H. radiator compl.	Radiateur D. compl.	R., Kühler kpl.	Radiador derech. compl.	
	2	8000 79077	1	Tappo	Plug	Bouchon	Verschluss	Tapón	
	3	8000 87120	1	Radiatore Sx.	L.H. radiator	Radiateur G.	L., Kühler	Radiador izrdo.	
	4	8000 43715	1	Tubetto sfiato	Tube	Tuyau	Rohr	Tubo	
	6	60NI 02525	1	Vite (M6x100 mm)	Screw (M6x100 mm)	Vis (M6x100 mm)	Schraube (M6x100 mm)	Tornillo (M6x100 mm)	
	7	8000 59802	4	Bussola	Bushing	Douille	Buchse	Manguito	
	8	8000 59803	6	Gommino	Rubber pad	Pièce caoutchouc	Gummstück	Junta de goma	
	9	8000 59801	4	Rosetta piana	Washer	Rondelle	Scheibe	Arandela	
	10	8000 62728	2	Vite (M6x20 mm)	Screw (M6x20 mm)	Vis (M6x20 mm)	Schraube (M6x20 mm)	Tornillo (M6x20 mm)	
	12	8000 66850	1	Tubo	Pipe	Tuyau	Schlauch	Tubo	
	13	8000 57242	2	Fascetta	Clamp	Collier	Schelle	Banda	
	14	8A00 66851	1	Tubo cilindro - radiatori	Pipe	Tuyau	Schlauch	Tubo	
	15	8000 35751	6	Fascetta	Clamp	Collier	Schelle	Banda	
	16	8000 67610	1	Fascetta	Clamp	Collier	Schelle	Banda	
	17	8000 87859	1	Anello di guida	Ring	Bague	Ring	Anillo	
	18	8000 67449	1	Gommino	Rubber pad	Pièce caoutchouc	Gummstück	Junta de goma	
	19	8000 66858	1	Distanziale	Spacer	Entretoise	Distanzstück	Separador	
	20	8000 44240	1	Dado	Nut	Ecrou	Mutter	Tuerca	
	21	8000 A0872	1	Griglia	Grille	Grille	Gitter	Parilla	
	22	8000 A0872	1	Griglia	Grille	Grille	Gitter	Parilla	
	23	8000 60873	4	Dado a graffetta	Nut	Ecrou	Mutter	Tuerca	
	26	8000 62725	2	Vite (M6x10 mm)	Screw (M6x10 mm)	Vis (M6x10 mm)	Schraube (M6x10 mm)	Tornillo (M6x10 mm)	
	27	8000 62725	1	Vite (M6x10 mm)	Screw (M6x10 mm)	Vis (M6x10 mm)	Schraube (M6x10 mm)	Tornillo (M6x10 mm)	
	28	62NI 15519	1	Rosetta piana	Washer	Rondelle	Scheibe	Arandela	
	32	8A00 72284	1	Ass. tubo	Pipe	Tuyau	Schlauch	Tubo	
	34	8000 46893	2	Dado a graffetta	Nut	Ecrou	Mutter	Tuerca	

35: 3+5, 7, 9, 10, 13, 17, 25, 27, 32, 33

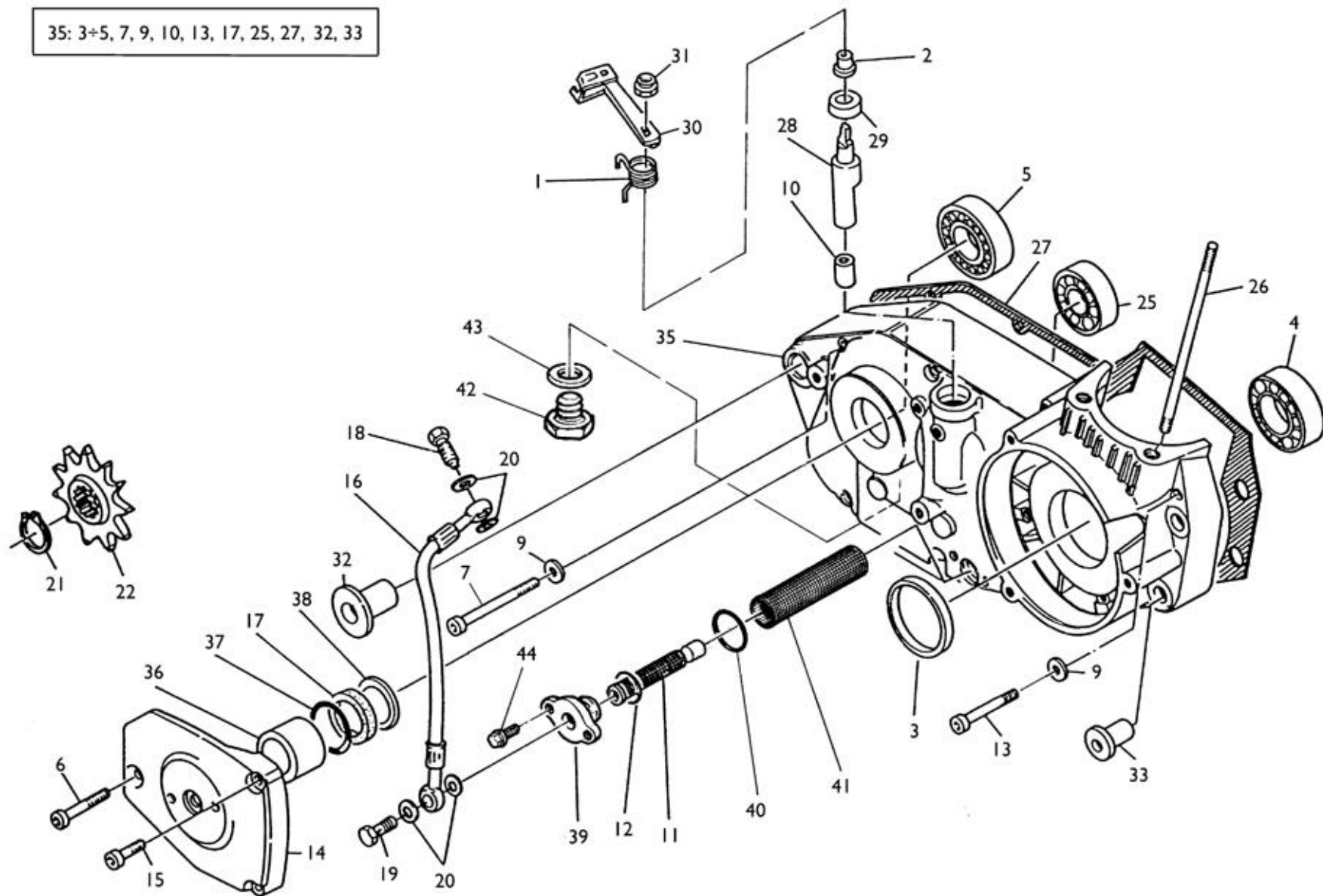

Note Notes Notas	Pos. No. Index Pos.	N. Cod. Code No. Nr. Code Code Nr N. Cod.	Q.tà Q.ty Q.te M.ge C.ad	DENOMINAZIONE	NAME	DESIGNATION	BESHREIBUNG	DENOMINACION	Validità Validity Validité Gültig Validez
	1	8A00 48188	1	Molla	Spring	Ressort	Feder	Resorte	
	2	8A00 55532	1	Bussola	Bushing	Douille	Buchse	Manguito	
	3	1513 72602	1	Anello di tenuta (ø30xØ52x7 mm)	Seal ring (ø30xØ52x7 mm)	Bague d'étanchéité (ø30xØ52x7 mm)	Dichtungsring (ø30xØ52x7 mm)	Anillo de retención (ø30xØ52x7 mm)	
	4	8000 28182	1	Cuscinetto (ø30xØ72x19 mm)	Bearing (ø30xØ72x19 mm)	Roulement (ø30xØ72x19 mm)	Lager (ø30xØ72x19 mm)	Cojinete (ø30xØ72x19 mm)	
	5	8000 43789	1	Cuscinetto (ø25xØ52x15 mm)	Bearing (ø25xØ52x15 mm)	Roulement (ø25xØ52x15 mm)	Lager (ø25xØ52x15 mm)	Cojinete (ø25xØ52x15 mm)	
	6	60NI 02513	1	Vite (M6X40 mm)	Screw (M6X40 mm)	Vis (M6X40 mm)	Schraube (M6X40 mm)	Tornillo (M6X40 mm)	
	7	60NI 02520	6	Vite (M6X75 mm)	Screw (M6X75 mm)	Vis (M6X75 mm)	Schraube (M6X75 mm)	Tornillo (M6X75 mm)	
	9	62NI 15504	9	Rosetta piana	Washer	Rondelle	Scheibe	Arandela	
	10	8000 68195	1	Bussola	Bushing	Douille	Buchse	Manguito	
	11	8000 72427	1	Filtro olio interno	Internal oil filter	Filtre à huile	Ölfilter	Filtro aceite	
	12	8000 26884	1	Anello di tenuta	Seal ring	Bague d'étanchéité	Dichtungsring	Anillo de retención	
	13	60NI 02515	3	Vite (M6X50 mm)	Screw (M6X50 mm)	Vis (M6X50 mm)	Schraube (M6X50 mm)	Tornillo (M6X50 mm)	
	14	1611 81604	1	Coperchio	Cover	Couvercle	Deckel	Tapa	
	15	60NI 02510	2	Vite (M6X25 mm)	Screw (M6X25 mm)	Vis (M6X25 mm)	Schraube (M6X25 mm)	Tornillo (M6X25 mm)	
	16	8000 65653	1	Tubo	Pipe	Tuyau	Schlauch	Tubo	
	17	8000 59977	1	Anello di tenuta (ø32xØ40x5 mm)	Seal ring (ø32xØ40x5 mm)	Bague d'étanchéité (ø32xØ40x5 mm)	Dichtungsring (ø32xØ40x5 mm)	Anillo de retención (ø32xØ40x5 mm)	
	18	8000 91743	1	Vite	Screw	Vis	Schraube	Tornillo	
	19	8000 45183	1	Vite	Screw	Vis	Schraube	Tornillo	
	20	8000 21480	4	Rosetta	Washer	Rondelle	Scheibe	Arandela	
	21	66N0 21211	1	Anello di fermo	Stop ring	Bague d'arrêt	Haltering	Anillo de retención	
W	22	8000 63832	1	Pignone (Z=17)	Pinion (Z=17)	Pignon (Z=17)	Ritzel (Z=17)	Piñón (Z=17)	
WD	22	8000 63829	1	Pignone (Z=14)	Pinion (Z=14)	Pignon (Z=14)	Ritzel (Z=14)	Piñón (Z=14)	
U	22	8000 63829	1	Pignone (Z=14)	Pinion (Z=14)	Pignon (Z=14)	Ritzel (Z=14)	Piñón (Z=14)	
M	22	8000 63832	1	Pignone (Z=17)	Pinion (Z=17)	Pignon (Z=17)	Ritzel (Z=17)	Piñón (Z=17)	
MD	22	8000 63830	1	Pignone (Z=15)	Pinion (Z=15)	Pignon (Z=15)	Ritzel (Z=15)	Piñón (Z=15)	
M	22	8000 63830	1	Pignone (Z=15) (USA)	Pinion (Z=15) (USA)	Pignon (Z=15) (USA)	Ritzel (Z=15) (USA)	Piñón (Z=15) (USA)	
	25	8000 19768	1	Cuscinetto (ø15xØ42x13 mm)	Bearing (ø15xØ42x13 mm)	Roulement (ø15xØ42x13 mm)	Lager (ø15xØ42x13 mm)	Cojinete (ø15xØ42x13 mm)	

35: 3+5, 7, 9, 10, 13, 17, 25, 27, 32, 33

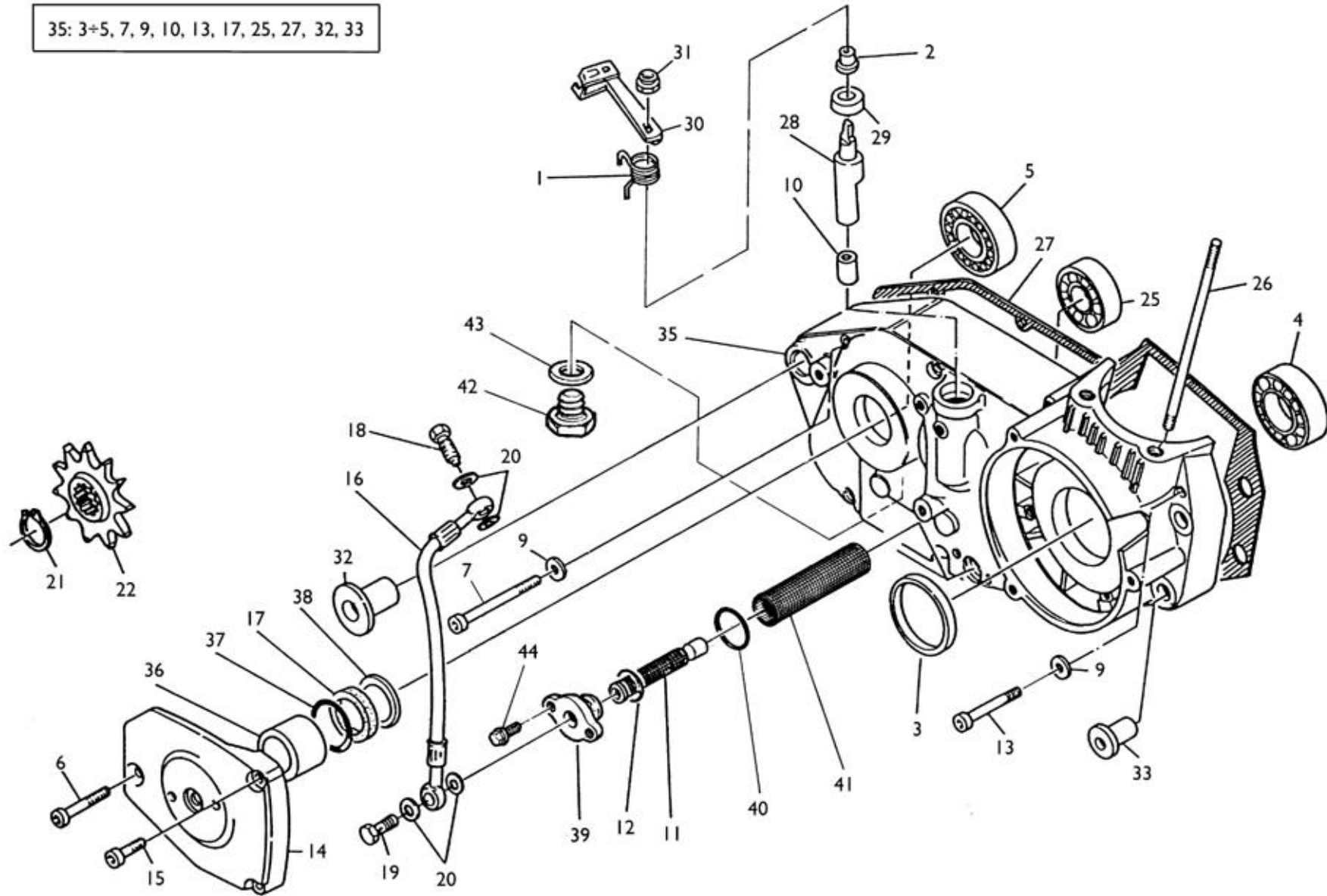

Note Notes Notas	Pos. No. Index Pos.	N. Cod. Code No. Nr. Code Code Nr N. Cod.	Q.tà Q.ty Q.te M.ge C.ad	DENOMINAZIONE	NAME	DESIGNATION	BESHREIBUNG	DENOMINACION	Validità Validity Validité Gültig Validez
	26	1615 11601	4	Prigioniero cilindro	Stud bolt	Prisonnier	Stiftschraube	Prisionero	
	27	1615 01404	1	Guarnizione	Gasket	Garnitue	Dichtung	Junta	
	28	8A00 68201	1	Albero comando frizione	Shaft	Arbre	Welle	Eje	
	29	1513 72201	1	Anello di tenuta (ø10xØ22x8 mm)	Seal ring (ø10xØ22x8 mm)	Bague d'étanchéité (ø10xØ22x8 mm)	Dichtungsring (ø10xØ22x8 mm)	Anillo de retención (ø10xØ22x8 mm)	
	30	8A00 68196	1	Leva	Lever	Levier	Hebel	Palanca	
	31	8000 56410	1	Dado	Nut	Ecrou	Mutter	Tuerca	
	32	8B0071154	1	Bussola	Bushing	Douille	Buchse	Manguito	
	33	1610 77701	2	Bussola	Bushing	Douille	Buchse	Manguito	
	35	8000 96874	1	Carter motore accoppiati comp.	Crankcase assy	Carter compl.	Kurberlgehäuse kpl.	Carter motor completi	
	36	8000 60464	1	Distanziale	Spacer	Entretoise	Distanzstück	Separador	
	37	8000 23110	1	Anello OR	O-Ring	Bague OR	O-Ring	Anillo OR	
	38	8A00 36022	1	Rosetta di rasamento (0,2 mm)	Washer (0,2 mm)	Rondelle (0,2 mm)	Scheibe (0,2 mm)	Arandela (0,2 mm)	
	38	8B00 36022	1	Rosetta di rasamento (0,3 mm)	Washer (0,3 mm)	Rondelle (0,3 mm)	Scheibe (0,3 mm)	Arandela (0,3 mm)	
	38	8C00 36022	1	Rosetta di rasamento (0,4 mm)	Washer (0,4 mm)	Rondelle (0,4 mm)	Scheibe (0,4 mm)	Arandela (0,4 mm)	
	38	8D00 36022	1	Rosetta di rasamento (0,5 mm)	Washer (0,5 mm)	Rondelle (0,5 mm)	Scheibe (0,5 mm)	Arandela (0,5 mm)	
	39	8A00 72425	1	Raccordo	Union	Raccord	Anschluss	Empalme	
	40	8000 34609	1	Anello di tenuta	Seal ring	Bague d'étanchéité	Dichtungsring	Anillo de retención	
	41	8000 72426	1	Filtro olio esterno	External oil filter	Filtre à huile	Ölfilter	Filtro aceite	
	42	8000 96747	1	Tappo	Plug	Bouchon	Verschluss	Tapòn	
	43	62N0 15682	1	Rosetta	Washer	Rondelle	Scheibe	Arandela	
	44	8A00 66525	2	Vite	Screw	Vis	Schraube	Tornillo	

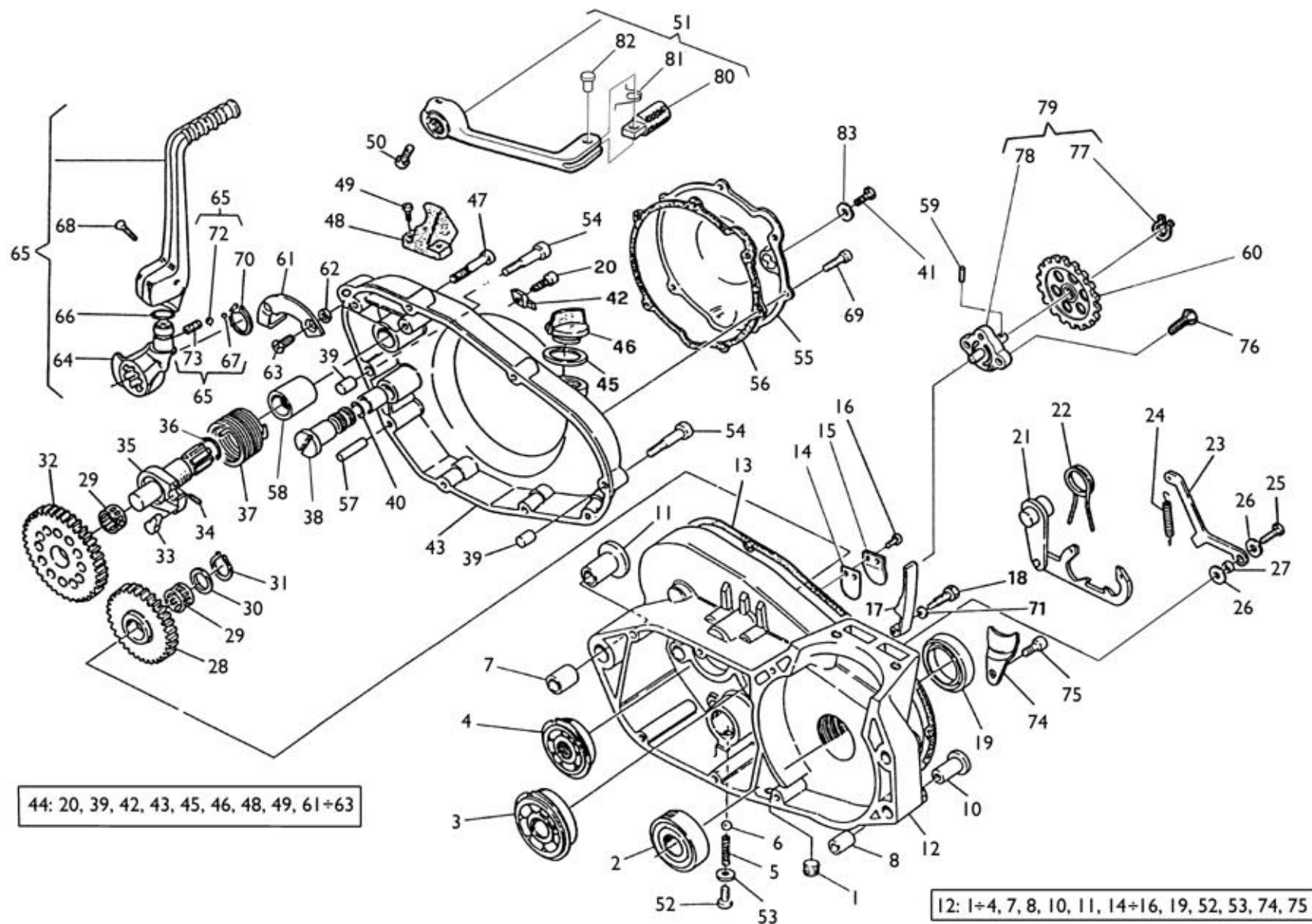

Note Notes Notas	Pos. No. Index Pos.	N. Cod. Code No. Nr. Code Code Nr N. Cod.	Q.tà Q.ty Q.te M.ge C.ad	DENOMINAZIONE	NAME	DESIGNATION	BESHREIBUNG	DENOMINACION	Validità Validity Validité Gültig Validez
	1	8000 69769	1	Tappo	Plug	Bouchon	Verschluss	Tapón	
	2	8A00 28182	1	Cuscinetto (ø30xØ72x19 mm)	Bearing (ø30xØ72x19 mm)	Roulement (ø30xØ72x19 mm)	Lager (ø30xØ72x19 mm)	Cojinete (ø30xØ72x19 mm)	
	3	8000 59975	1	Cuscinetto (ø25xØ52x15 mm)	Bearing (ø25xØ52x15 mm)	Roulement (ø25xØ52x15 mm)	Lager (ø25xØ52x15 mm)	Cojinete (ø25xØ52x15 mm)	
	4	8000 59976	1	Cuscinetto (ø17xØ47x14 mm)	Bearing (ø17xØ47x14 mm)	Roulement (ø17xØ47x14 mm)	Lager (ø17xØ47x14 mm)	Cojinete (ø17xØ47x14 mm)	
	5	8000 61263	1	Molla	Spring	Ressort	Feder	Resorte	
	6	8000 60476	1	Sfera	Ball	Bille	Kugel	Esfera	
	7	1614 59002	1	Bussola di riferimento	Bushing	Douille	Buchse	Manguito	
	8	1610 77601	1	Bussola di riferimento	Bushing	Douille	Buchse	Manguito	
	10	1610 77701	1	Bussola	Bushi,g	Douille	Buchse	Manguito	
	11	8B00 71154	1	Bussola	Bushing	Douille	Buchse	Manguito	
	12	8000 96874	1	Carter motore accoppiati compl.	Crankcase assy	Carter compl.	Kurberlgehause kpl.	Carter motor completi	
	13	1611 65003	1	Guarnizione	Gasket	Garnitue	Dichtung	Junta	
	14	1615 34801	1	Valvola lamellare	Reed valve	Soupape lamellaire	Ventil lamellar	Válvula laminar	
	15	1615 10501	1	Supporto	Support	Support	Halterung	Soporte elástico	
	16	60NI 02866	2	Vite	Screw	Vis	Schraube	Tornillo	
	17	8000 68686	1	Tendicatena distr.	Chain adjuster	Tendeur de chaine	Kettenspanner	Tensor de cadena	
	18	1615 35902	1	Vite	Screw	Vis	Schraube	Tornillo	
	19	1513 72602	1	Anello di tenuta (ø30xØ52x7 mm)	Seal ring (ø30xØ52x7 mm)	Bague d'étanchéité (ø30xØ52x7 mm)	Dichtungsring (ø30xØ52x7 mm)	Anillo de retención (ø30xØ52x7 mm)	
	20	8000 26970	1	Vite	Screw	Vis	Schraube	Tornillo	
	21	1611 68601	1	Selettore cambio	Selector	Selecteur	Waehler	Selector com.	
	22	1611 69201	1	Molla	Spring	Ressort	Feder	Resorte	
	23	8000 90054	1	Saltarello	Click	Cliquet	Strumhaken	Saltarello	
	24	1611 68401	1	Molla	Spring	Ressort	Feder	Resorte	
	25	8000 47422	1	Vite	Screw	Vis	Schraube	Tornillo	

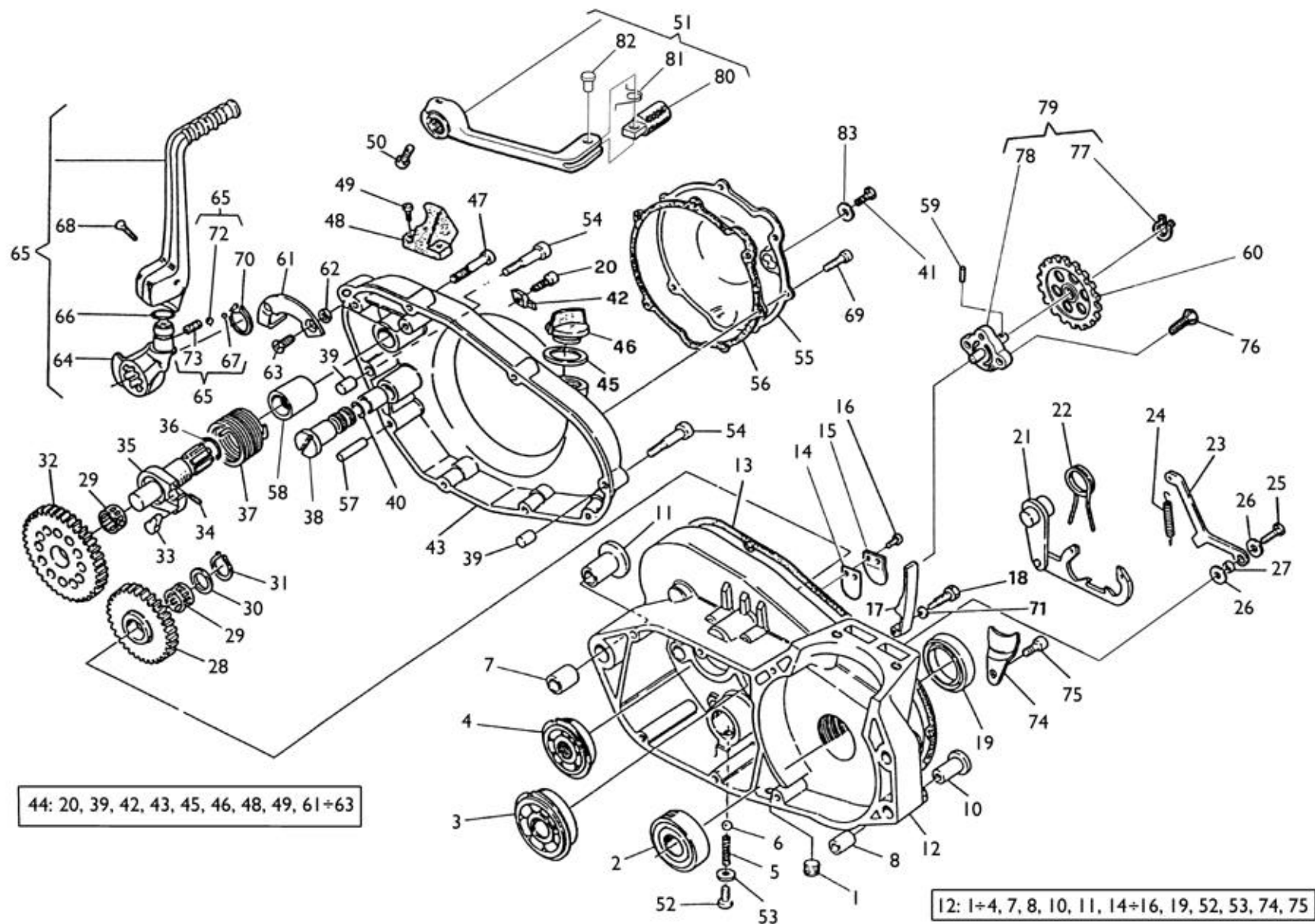

Note Notes Notas	Pos. No. Index Pos.	N. Cod. Code No. Nr. Code Code Nr N. Cod.	Q.tà Q.ty Q.te M.ge C.ad	DENOMINAZIONE	NAME	DESIGNATION	BESHREIBUNG	DENOMINACION	Validità Validity Validité Gültig Validez
	26	8A00 37003	1	Rosetta piana	Washer	Rondelle	Scheibe	Arandela	
	27	1611 21601	1	Bussola	Bushing	Douille	Buchse	Manguito	
	28	1611 27101	1	Ingranaggio di rinvio (Z=25)	Gear (Z=25)	Engranage (Z=25)	Zahnrad (Z=25)	Engranaje (Z=25)	
	29	8000 40449	2	Cuscinetto a rullini	Needle bearing	Roulement à aiguilles	Nadelkäfig	Cojinete de rodillos	
	30	8000 38110	1	Rosetta di rasamento (0,3 mm)	Washer (0,3 mm)	Rondelle (0,3 mm)	Scheibe (0,3 mm)	Arandela (0,3 mm)	
	30	8B00 38110	1	Rosetta di rasamento (0,5 mm)	Washer (0,5 mm)	Rondelle (0,5 mm)	Scheibe (0,5 mm)	Arandela (0,5 mm)	
	30	8F00 38110	1	Rosetta di rasamento (1,0 mm)	Washer (1,0 mm)	Rondelle (1,0 mm)	Scheibe (1,0 mm)	Arandela (1,0 mm)	
	31	66N0 21205	1	Anello di fermo	Stop ring	Bague d'arrêt	Haltering	Anillo de retención	
	32	1615 39101	1	Ingranaggio avviamento (Z=35)	Driven gear (Z=35)	Engranage conduit (Z=35)	Zahnrad (Z=35)	Engranaje conducto (Z=35)	
	33	1611 68001	1	Saltarello	Click	Cliquet	Strumhaken	Saltarelo	
	34	1611 68101	1	Molla	Spring	Ressort	Feder	Resorte	
	35	1611 67702	1	Albero avviamento	Starter crank shaft	Arbre de démarrage	Kickstarterwelle	Eje arranque	
	36	8000 60475	2	Anello OR	O-Ring	Bague OR	O-Ring	Anillo OR	
	37	1616 36201	1	Molla	Spring	Ressort	Feder	Resorte	
	38	1611 74601	1	Albero pedale cambio	Gearbox pedal shaft	Arbre pédale change de vitesse	Pedal Umsteuerungswelle	Eje pedal cambio	
	39	1611 70801	2	Spina di riferimento	Pin	Goupille	Stift	Clavija	
	40	8000 60474	2	Anello OR	O-Ring	Bague OR	O-Ring	Anillo OR	
	41	8000 35099	1	Vite livello olio	Oil level screw	Vis controle huile	Olcontrolschraube	Tornillo nivel aceite	
	42	8000 68710	1	Gommino	Rubber pad	Pièce caoutchouc	Gummstück	Junta de goma	
	43	8AA0 67194	1	Coperchio trasmissione	Cover	Couvercle	Deckel	Tapa	
	44	8C00 75764	1	Coperchio trasmissione compl.	Cover assy	Couvercle compl.	Deckel Kpl.	Tapa compl.	
	45	8000 27960	1	Guarnizione	Gasket	Garnitue	Dichtung	Junta	
	46	8000 36786	1	Tappo	Plug	Bouchon	Verschluss	Tapón	
	47	60NI 02512	6	Vite (M6X35 mm)	Screw (M6X35 mm)	Vis (M6X35 mm)	Schraube (M6X35 mm)	Tornillo (M6X35 mm)	
	48	8000 68584	1	Tampone ferma pedale	Pad	Tampon	Stopfen	Tampón	
	49	60NI 02900	2	Vite	Screw	Vis	Schraube	Tornillo	
	50	60NI 02509	1	Vite	Screw	Vis	Schraube	Tornillo	
	51	8000 92944	1	Leva cambio compl.	Gearchange lever	Levier comm. vitesse	Schalthebel	Palanca del cambio	
	52	8000 66101	1	Vite	Screw	Vis	Schraube	Tornillo	
	53	8000 47763	1	Bussola	Bushing	Douille	Buchse	Manguito	
	54	60NI 02513	2	Vite (M6X40 mm)	Screw (M6X40 mm)	Vis (M6X40 mm)	Schraube (M6X40 mm)	Tornillo (M6X40 mm)	

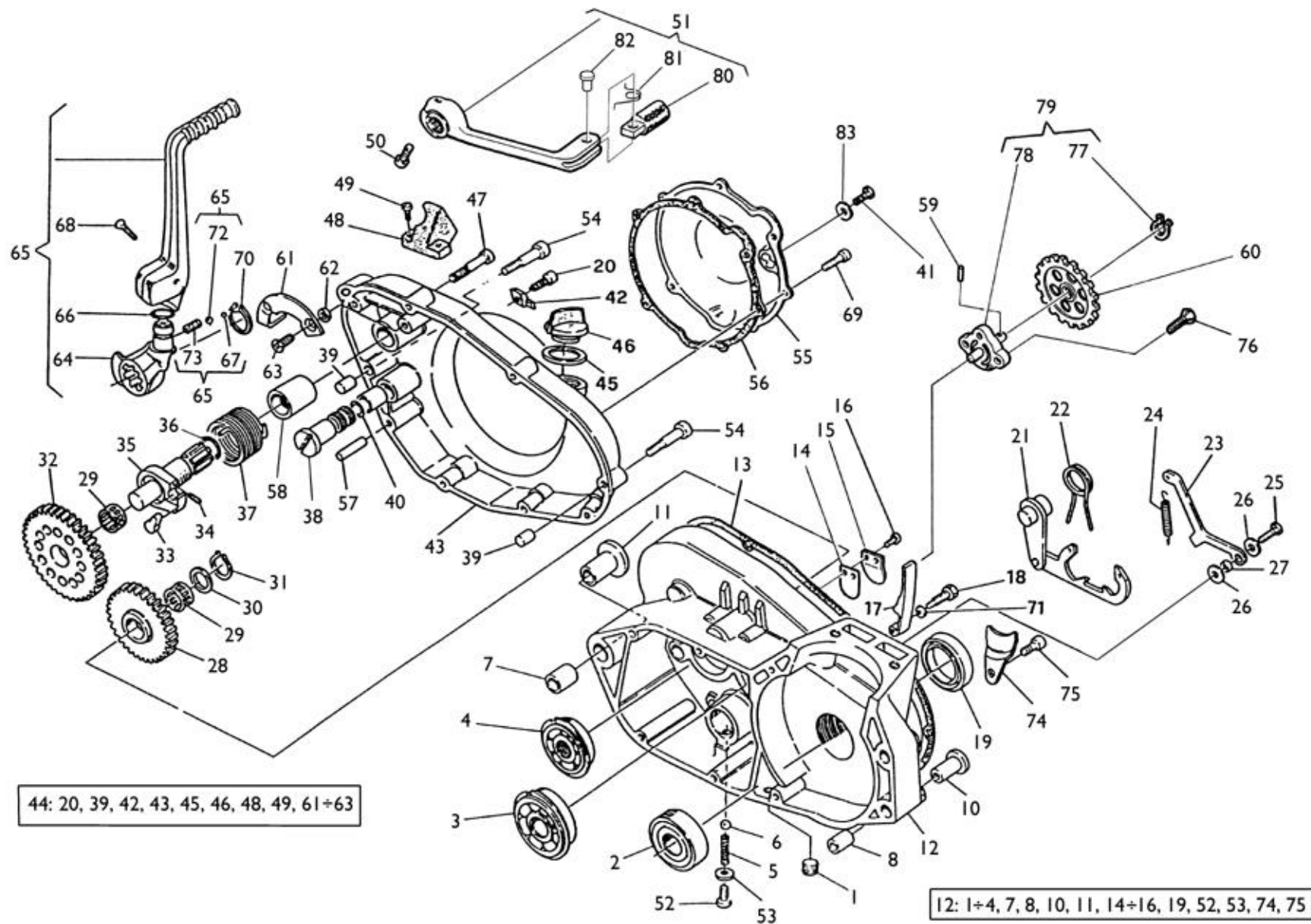

Note Notes Notas	Pos. No. Index Pos.	N. Cod. Code No. Nr. Code Code Nr N. Cod.	Q.tà Q.ty Q.te M.ge C.ad	DENOMINAZIONE	NAME	DESIGNATION	BESHREIBUNG	DENOMINACION	Validità Validity Validité Gültig Validez
	55	80A0 96889	1	Coperchio	Cover	Couvercle	Deckel	Tapa	
	56	8A00 96890	1	Guarnizione	Gasket	Garnitue	Dichtung	Junta	
	57	8000 60477	1	Spina di riferimento	Pin	Goupille	Stift	Clavija	
	58	1614 46901	1	Bussola	Bushing	Douille	Buchse	Manguito	
	59	8C00 27690	1	Rullino	Roller	Aiguille	Rolle	Rodillo	
	60	8000 90052	1	Ingranaggio pompa	Pump gear	Engrenage	Zahnrad	Engranaje	
	61	1611 70401	1	Piastrina fine corsa	Plate	Plaquette	Plättchen	Placa	
	62	1611 70601	2	Distanziale	Spacer	Entretoise	Distanzstück	Separador	
	63	8000 60577	2	Vite	Screw	Vis	Schraube	Tornillo	
	64	8000 68174	1	Mozzetto	Hub	Moyeau	Radnabe	Cubo	
	65	8000 84321	1	Pedale avviamento completo	Pedal	Pedale	Pedal	Pedal	
	66	8000 31271	1	Anello OR	O-Ring	Bague OR	O-Ring	Anillo OR	
	67	1611 08501	1	Tappo	Plug	Bouchon	Verschluss	Tapón	
	68	8000 58140	1	Vite	Screw	Vis	Schraube	Tornillo	
	69	60N1 07335	6	Vite	Screw	Vis	Schraube	Tornillo	
	70	66N0 21208	1	Anello di fermo	Stop ring	Bague d'arrêt	Haltering	Anillo de retención	
	71	8000 45194	1	Rosetta	Washer	Rondelle	Scheibe	Arandela	
	72	8000 60472	1	Sfera	Ball	Bille	Kugel	Esfera	
	73	1611 08401	1	Molla	Spring	Ressort	Feder	Resorte	
	74	8000 61269	1	Piastrina	Plate	Plaquette	Plättchen	Placa	
	75	60N1 02504	1	Vite	Screw	Vis	Schraube	Tornillo	
	76	8000 60577	2	Vite	Screw	Vis	Schraube	Tornillo	
	77	8000 90057	1	Anello elastico	Split ring	Anneau ressort	Sprengring	Anillo elástico	
	78	8000 89829	1	Pompa olio	Oil pump	Pompe huile	ölpumpen	Bombedora aceite	
	79	8000 90056	1	Ass. pompa olio	Oil pump assy	Groupe pompe huile	ölpumpen Kpl	Grupo bombedora aceite	
	80	8000 70215	1	Pedalino	Pedal	Pedale	Pedal	Pedal	
	81	8000 70216	1	Molla	Spring	Ressort	Feder	Resorte	
	82	8000 70217	1	Ribattino	Rivet	Rivet	Niet	Remache	
	83	8000 64988	1	Rosetta piana	Washer	Rondelle	Scheibe	Arandela	

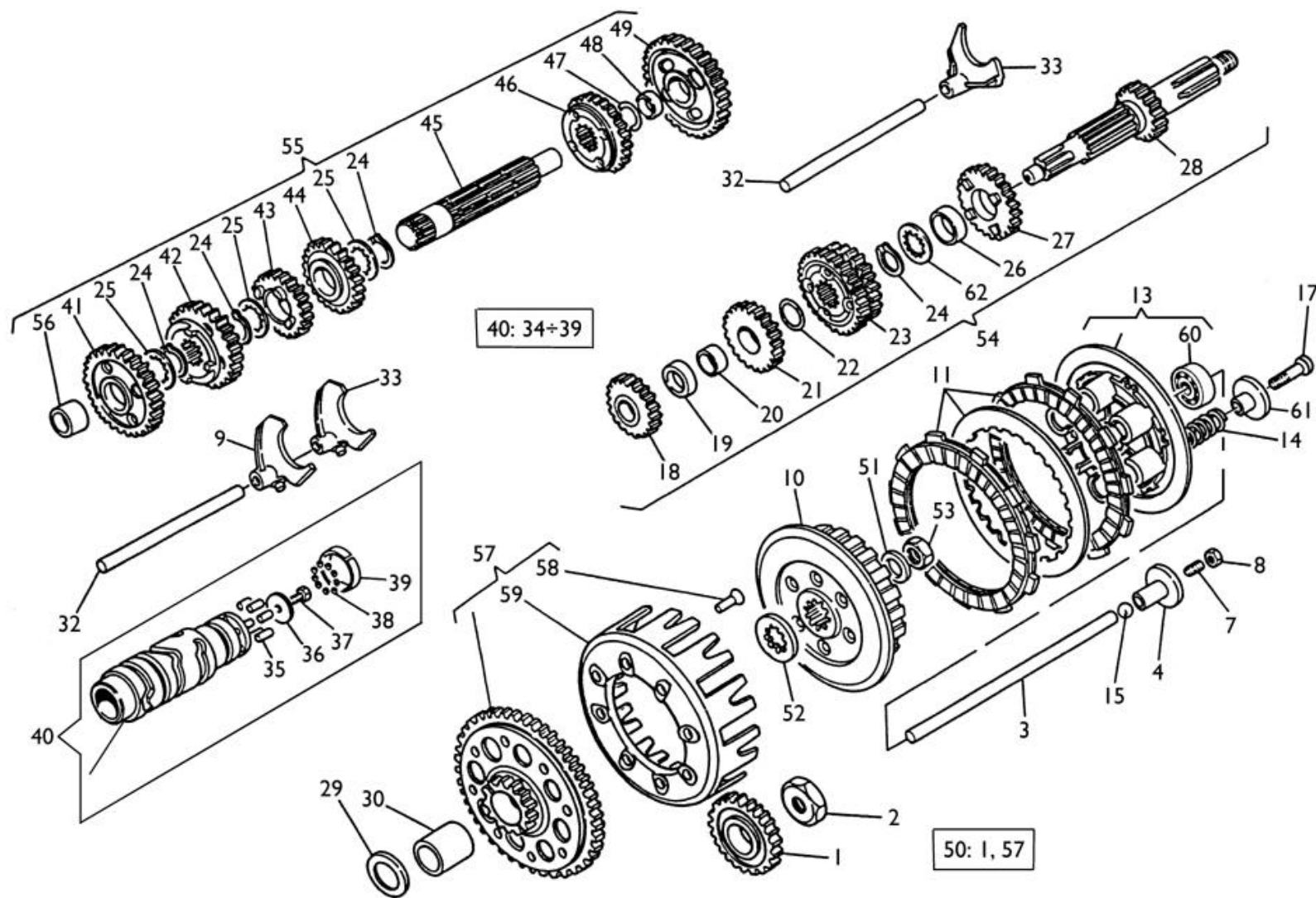

Note Notes Marka Notas	Pos. No. Index Pos.	N. Cod. Code No. Nr. Code Code Nr N. Cod.	Q.tà Q.ty Q.te M.ge C.ad	DENOMINAZIONE	NAME	DESIGNATION	BESHREIBUNG	DENOMINACION	Validità Validity Validité Gültig Validez
	1	8000 69715	1	Ingranaggio conduttore	Driving gear	Engranage conducteur	Zahnrad	Engranaje conductor	
	2	8000 59965	1	Dado	Nut	Ecrou	Mutter	Tuerca	
	3	1615 31502	1	Asta di forza	Fork tube	Barre de force	Druckstab	Varilla de fuerza	
	4	8000 96754	1	Piattello	Plate	Plateau	Teller	Placa	
	7	8000 54692	1	Vite	Screw	Vis	Schraube	Tornillo	
	8	61N1 15062	1	Dado	Nut	Ecrou	Mutter	Tuerca	
	9	8000 63425	1	Forcella 3ª vel.	Fork	Fourche	Gabel	Horquilla	
	10	8A00 96746	1	Mozzo frizione	Hub	Moyeau	Radnabe	Cubo	
	11	8000 99521	7	Disco conduttore	Driving disc	Disque conducteur	Belagscheibe	Disco conductor	
	11	8A00 81510	6	Disco condotto	Driven disc	Disque conduit	Stahlscheibe	Disco conducido	
	13	8000 81508	1	Piastra spingidisci	Plate	Plaque	Platte	Placa	
	14	8000 96888	6	Molla frizione	Clutch spring	Ressort embrayage	Kupplungsfeder	Resorte embrague	
	15	6BN0 21509	1	Sfera	Ball	Bille	Kugel	Esfera	
	17	60N1 02510	6	Vite	Screw	Vis	Schraube	Tornillo	
	18	1612 36201	1	Ingranaggio 2ª A.P. (Z=16)	Main shaft 2nd gear (Z=16)	Engrenage 2ème vitesse A.P. (Z=16)	Zahnw. f. 2. Geschw. . (Z=16)	Engranaje 2º velocidad Eje P. (Z=16)	
	19	1612 48101	1	Distanziale	Spacer	Entretoise	Distanzstück	Separador	
	20	1612 48001	1	Bussola	Bushing	Douille	Buchse	Manguito	
	21	1612 36301	1	Ingranaggio 3ª A.P. (Z=19)	Main shaft 3rd gear (Z=19)	Engrenage 3ème vitesse A.P. (Z=19)	Zahnw. f. 3. Geschw. Antriebsw. (Z=19)	Engranaje 3º velocidad Eje P. (Z=19)	
	22	1612 84201	1	Rosetta	Washer	Rondelle	Scheibe	Arandela	
	23	1612 39001	1	Ingran. 5ª e 6ª A.P. (Z=25/27)	Gear 5th - 6th speed (Z=25/27)	Engranage 5ème 6ème (Z=25/27)	Zahnrad 5. - 6. Gang (Z=25/27)	Engranaje 5º - 6º velocidad (Z=25/27)	
	24	66N0 21211	4	Anello di fermo	Stop ring	Bague d'arrêt	Haltering	Anillo de retención	
	25	1611 71701	3	Rosetta	Washer	Rondelle	Scheibe	Arandela	
	26	8000 63821	1	Bussola	Bushing	Douille	Buchse	Manguito	
	27	1611 83701	1	Ingranaggio 4ª A.P. (Z=23)	Main shaft 4th gear (Z=23)	Engrenage 4ème vitesse A.P. (Z=23)	Zahnw. f. 4. Geschw. Antriebsw. (Z=23)	Engranaje 4º velocidad Eje P. (Z=23)	
	28	8000 69736	1	Albero primario	Main shaft	Arbre primaire	Hauptwelle	Eje primario	
	29	8E00 30053	1	Rosetta di rasamento	Washer	Rondelle	Scheibe	Arandela	
	30	1615 38801	1	Bussola	Bushing	Douille	Buchse	Manguito	

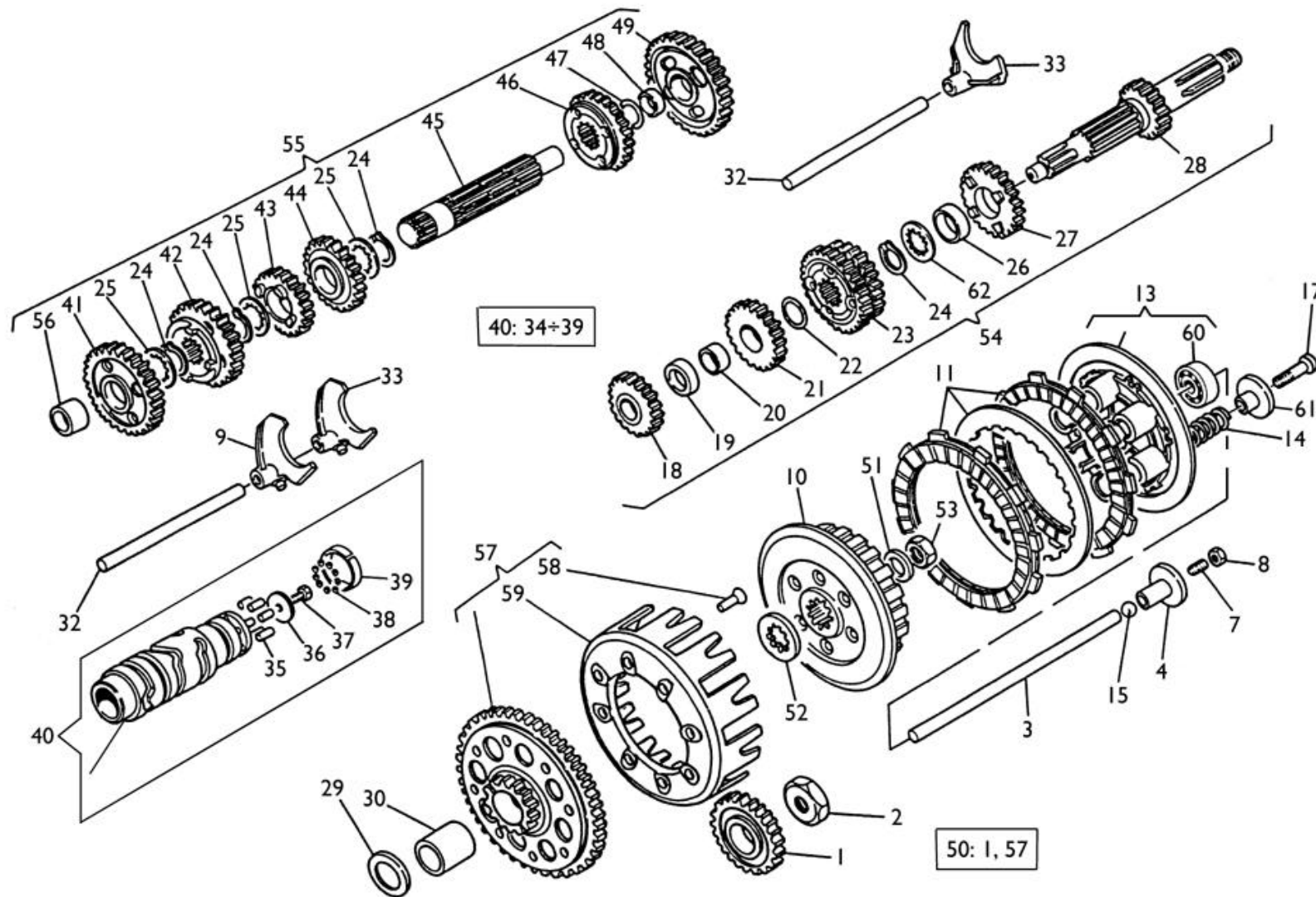

Note Notes Notas	Pos. No. Index Pos.	N. Cod. Code No. Nr. Code Code Nr N. Cod.	Q.tà Qty Q.te M.ge C.ad	DENOMINAZIONE	NAME	DESIGNATION	BESHREIBUNG	DENOMINACION	Validità Validity Validité Gültig Validez
	32	1611 69901	2	Perno	Pin	Pivot	Bolzen	Perno	
	33	1612 38401	2	Forcella cambio	Fork	Fourche	Gabel	Horquilla	
	35	8000 35823	6	Rullino	Roller	Aiguille	Rolle	Rodillo	
	36	8000 30326	1	Rosetta	Washer	Rondelle	Scheibe	Arandela	
	37	8000 60473	1	Vite	Screw	Vis	Schraube	Tornillo	
	38	8000 60472	11	Sfera	Ball	Bille	Kugel	Esfera	
	39	1612 69901	1	Anello esterno	Ring	Bague	Ring	Anillo	
	40	1611 70101	1	Albero forcelle cambio compl.	Driving shaft gearbox forks	Arbre comm. fourches trans.	Antriebswelle Schaltgabel	Eje mando horquilla cambio	
	41	1612 36502	1	Ingranaggio 2 ^a A.S. (Z=29)	Secondary shaft 2nd gear (Z=29)	Engrenage 2ème vitesse A.S. (Z=29)	Zah. f. 2. Geschw. Vorgelegew. (Z=29)	Engranaje 2° velocidad Eje S. (Z=29)	
	42	8000 63424	1	Ingranaggio 3 ^a A.S. (Z=26)	Secondary shaft 3rd gear (Z=26)	Engrenage 3ème vitesse A.S. (Z=26)	Zah. f. 3. Geschw. Vorgelegew. (Z=26)	Engranaje 3° velocidad Eje S. (Z=26)	
	43	1612 35701	1	Ingranaggio 6 ^a A.S. (Z=20)	Secondary shaft 6th gear (Z=20)	Engrenage 6ème vitesse A.S. (Z=20)	Zah. f. 6. Geschw. Vorgelegew. (Z=20)	Engranaje 6° velocidad Eje S. (Z=20)	
	44	1611 71501	1	Ingranaggio 5 ^a A.S. (Z=22)	Secondary shaft 5th gear (Z=22)	Engrenage 5ème vitesse A.S. (Z=22)	Zah. f. 5. Geschw. Vorgelegew. (Z=22)	Engranaje 5° velocidad Eje S. (Z=22)	
	45	8000 60463	1	Albero secondario	Layshaft	Arbre secondaire	Vorgelegewelle	Eje secundario	
	46	1612 38801	1	Ingranaggio 4 ^a A.S. (Z=24)	Secondary shaft 4th gear (Z=24)	Engrenage 4ème vitesse A.S. (Z=24)	Zah. f. 4. Geschw. (Z=24)	Engranaje 4° velocidad Eje S. (Z=24)	
	47	1513 71401	1	Rosetta	Washer	Rondelle	Scheibe	Arandela	
	48	1612 41501	1	Bussola	Bushing	Douille	Buchse	Manguito	
	49	1612 36101	1	Ingranaggio 1 ^a A.S. (Z=34)	Gear 1st speed (Z=34)	Engrenage 1ère (Z=34)	Zahnrad 1. Gang (Z=34)	Engranaje 1° velocidad (Z=34)	
	50	8000 69729	1	Coppia ingran. trasm. primaria	Set of matched primary	Engrenages trans. prim.	Stirnraderpaar	Copla engranaje trans. prim.	
	51	8000 36857	1	Rosetta di sicurezza	Washer	Rondelle	Scheibe	Arandela	
	52	8A00 38350	1	Rosetta	Washer	Rondelle	Scheibe	Arandela	
	53	8000 36856	1	Dado	Nut	Ecrou	Mutter	Tuerca	
	54	8000 69737	1	Albero primario completo	Main shaft	Arbre primaire	Hauptwelle	Eje principal completo	
	55	8000 60470	1	Albero secondario completo	Layshaft compl.	Arbre secondaire compl.	Vorgelegewelle kpl.	Eje secundario compl.	
	56	8000 63822	1	Bussola	Bushing	Douille	Buchse	Manguito	
	57	8000 69722	1	Campana frizione completo	Clutch housing compl.	Cage embrayage compl.	Kupplungskorb kpl.	Campana embrague compl.	

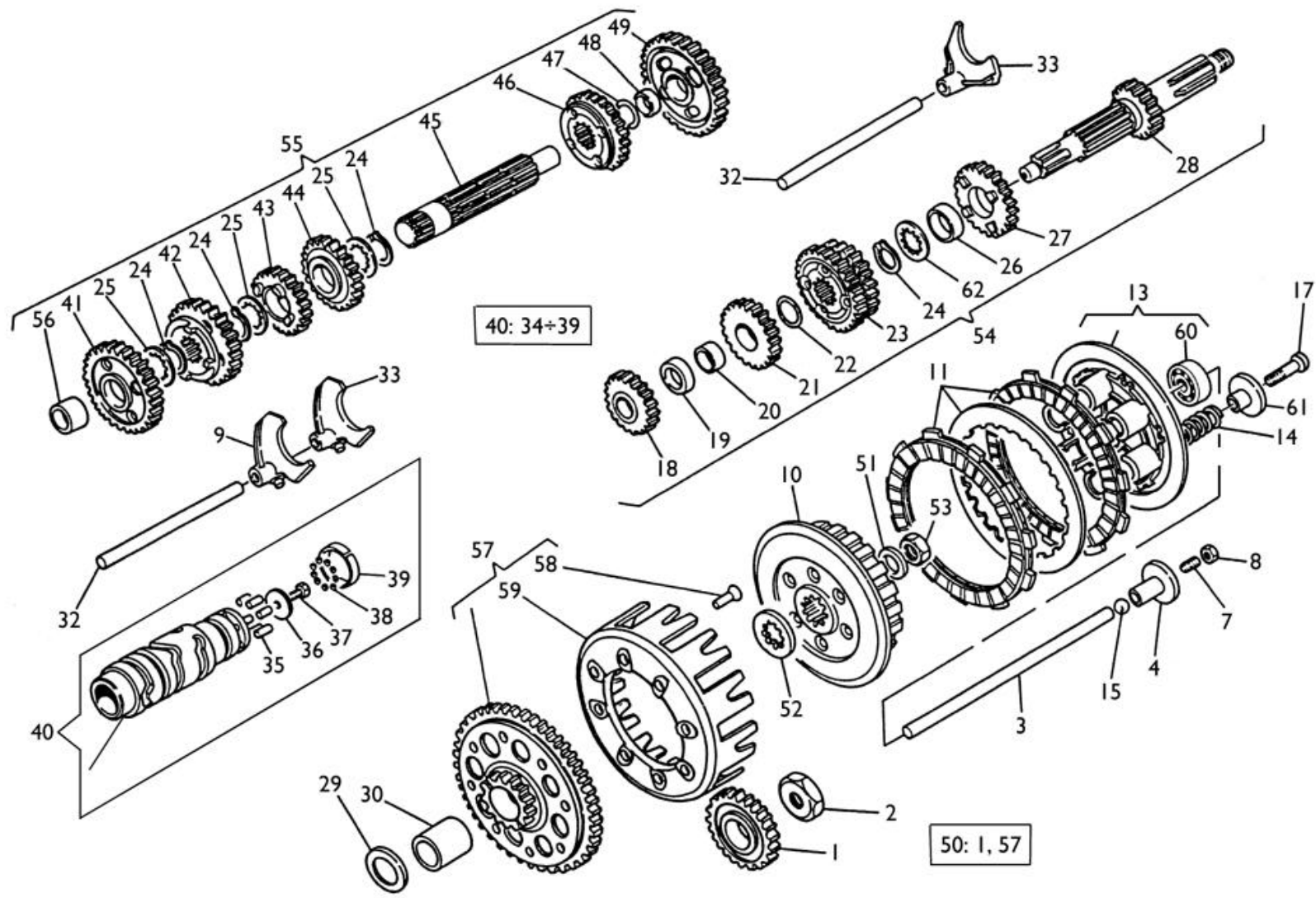

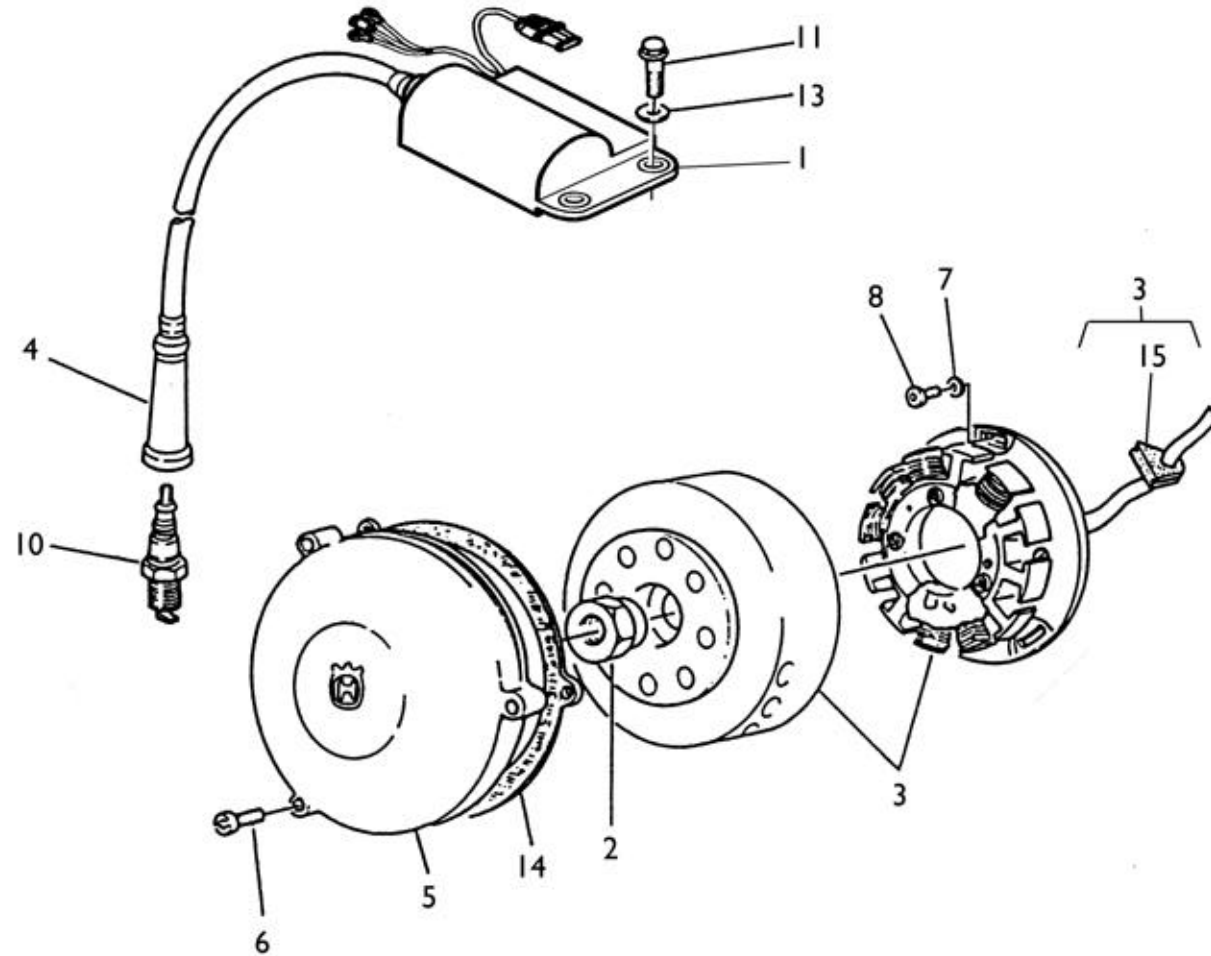

Note Notes Marka Notas	Pos. No. N. Index Pos.	N. Cod. Code No. Nr. Code Code Nr N. Cod.	Q.tà Q.ty Q.te M.ge C.ad	DENOMINAZIONE	NAME	DESIGNATION	BESHREIBUNG	DENOMINACION	Validità Validity Validité Gültig Validez
	1	8000 94008	1	Bobina completa	Coil compl.	Bobine compl.	Zündspule kpl.	Bobina compl.	
	2	8A00 59964	1	Dado	Nut	Ecrou	Mutter	Tuerca	
	3	8000 77391	1	Alternatore compl.	Alternator compl.	Alternateur compl.	Lichtmaschine kpl.	Alternador compl.	
	4	8000 A0129	1	Cappuccio candela	Cap	Capuchon	Kappe	Capuchón	
	5	80D0 60559	1	Coperchio accensione	Cover	Couvercle	Deckel	Tapa	
	6	60NI 02513	3	Vite	Screw	Vis	Schraube	Tornillo	
	7	8000 85322	3	Rosetta	Washer	Rondelle	Scheibe	Arandela	
	8	60NI 02487	3	Vite	Screw	Vis	Schraube	Tornillo	
	10	1615 38302	1	Candela NGK	Spark plug	Bougie	Zündkerze	Bujía	
A	10	8000 77478	1	Candela CHAMPION	Spark plug	Bougie	Zündkerze	Bujía	
	11	8C00 67997	2	Vite	Screw	Vis	Schraube	Tornillo	
	13	62N4 15548	2	Rosetta	Washer	Rondelle	Scheibe	Arandela	
	14	1615 27501	1	Guarnizione	Gasket	Garnitue	Dichtung	Junta	
	15	1614 72801	1	Gommino	Gasket	Garnitue	Dichtung	Junta	

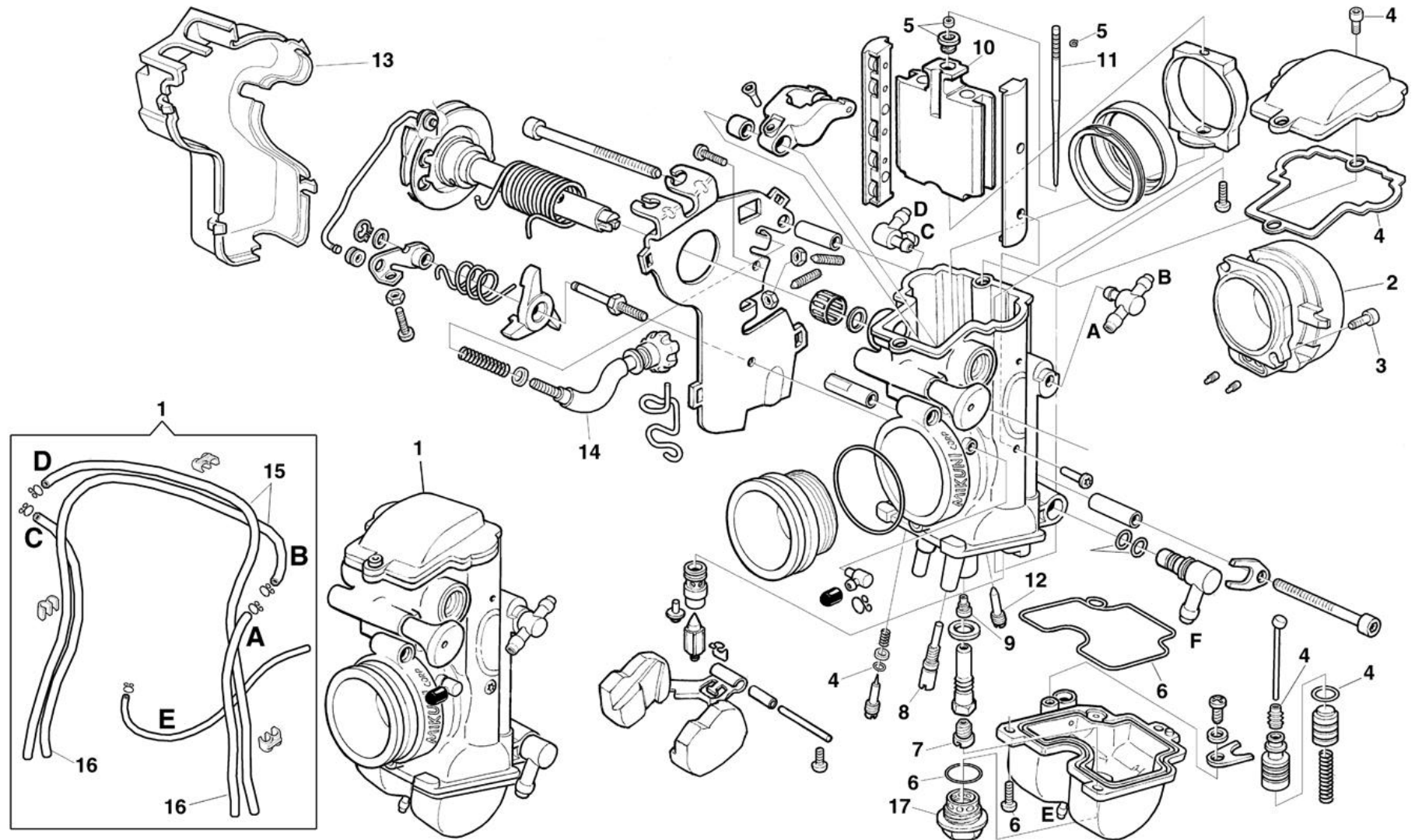

Note Notes Notas	Pos. No. Index Pos.	N. Cod. Code No. Nr. Code Code Nr N. Cod.	Q.tà Q.ty Q.te M.ge C.ad	DENOMINAZIONE	NAME	DESIGNATION	BESHREIBUNG	DENOMINACION	Validità Validity Validité Gültig Validez
	1	8000 A0131	1	Carburatore completo	Carburetor assy	Carbureteur complet	Vegaser, kpl.	Carburador compl.	
	2	8000 A0919	1	Cornetto presa aria	Pipe	Manchon	Muffe	Tubo toma aire	
	3	60N3 02461	2	Vite	Screw	Vis	Schraube	Tornillo	
	4	8000 A1794	1	Kit O Ring - viti	O Ring - Screw kit	Kit O Rings - Vis	O Rings - Schrauben Kit	Kit O Rings - Tornillos	
	5	8000 A1796	1	Kit getto- Polverizzatore	Jet-Fuel nozzle kit	Kit Gicleur - Pulvérisateur	Düse- Einspritzdüse Kit	Kit Chiclé - Pulverizador	
	6	8000 A1795	1	Kit O Ring - viti	O Rings - Screws kit	Kit O Rings - Vis	O Rings - Schrauben Kit	Kit O Rings - Tornillos	
	7	8V00 80171	1	Getto massimo (175)	Main jet (175)	Gicleur principal (175)	Hauptdüse (175)	Chiclé máximo (175)	
	8	8B00 A1804	1	Getto minimo (35)	Idle jet (35)	Gicleur minimum (35)	Leerlaufdüse (35)	Chiclé mínimo (35)	
	9	8C00 A1806	1	Polverizzatore (P 6)	Fuel nozzle (P 6)	Pulvérisateur (P 6)	Einspritzdüse (P 6)	Pulverizador (P 6)	
	10	8000 A1807	1	Válvulas (L0)	Throttle valve (L0)	Regul. de gas (L0)	Drosselklappe (L0)	Válvula (L0)	
	11	8000A1808	1	Spillo conico (52)	Needle (52)	Poinçon conique (52)	Kon.Nadel (52)	Passador cónico (52)	
	12	8A00A1809	1	Getto pompa (35)	Pump jet (35)	Gicleur pompe (35)	Pumpe Düse (35)	Chiclé bomba (35)	
	13	8000A1798	1	Coperchio	Cover	Couvercle	Deckel	Tapa	
	14	8000A1799	1	Cavo regolazione	Adjusting cable	Fil de réglage	Reglerkabel	Trans.de regulación	
	15	8000A1800	2	Tubazione (L=750mm)	Pipe (L=750mm)	Tuyau (L=750mm)	Rohr (L=750mm)	Tubo (L=750mm)	

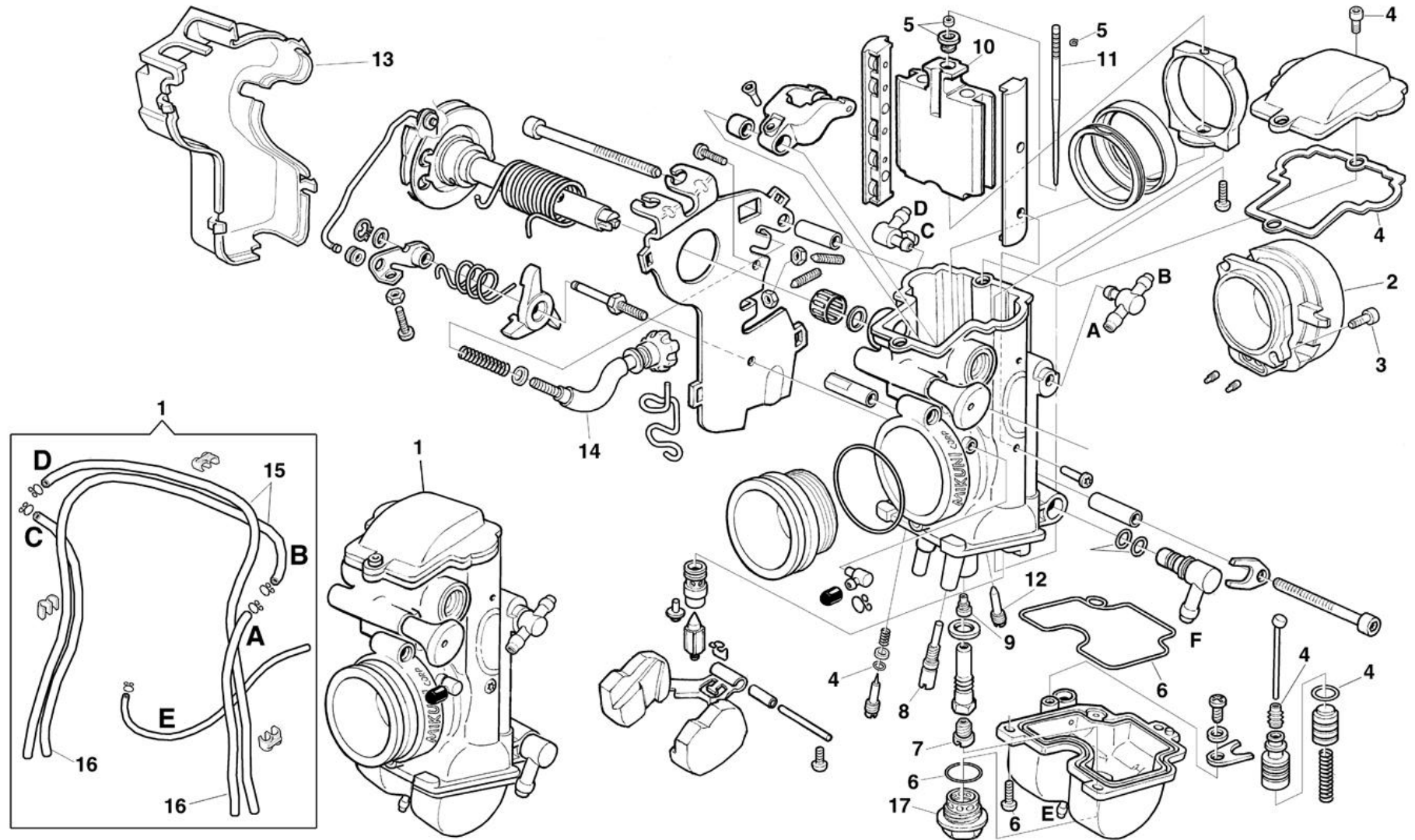

Note Notes Marka Notas	Pos. No. Index Pos.	N. Cod. Code No. Nr. Code Code Nr N. Cod.	Q.tà Q.ty M.ge C.ad	DENOMINAZIONE	NAME	DESIGNATION	BESHREIBUNG	DENOMINACION	Validità Validity Validité Gültig Validez
	16	8A00 A1800	2	Tubazione (L=550 mm)	Pipe (L=550 mm)	Tuyau (L=550 mm)	Rohr (L=550 mm)	Tubo (L=550 mm)	
	17	8000 A1803	1	Tappo	Plug	Bouchon	Verschluss	Tapón	
	18	8000 A1824	1	Kit carburatore	Carburetor kit	Kit carburateur	Vergaser Kit	Kit carburador	
	19	8W00 80171	1	Getto massimo (167,5)	Main jet (167,5)	Gicleur principal (167,5)	Hauptdüse (167,5)	Chiclé máximo (167,5)	
	19	8T00 80171	1	Getto massimo (170)	Main jet (170)	Gicleur principal (170)	Hauptdüse (170)	Chiclé máximo (170)	
	19	8U00 80171	1	Getto massimo (172,5)	Main jet (172,5)	Gicleur principal (172,5)	Hauptdüse (172,5)	Chiclé máximo (172,5)	
	19	8W00 80171	1	Getto massimo (177,5)	Main jet (177,5)	Gicleur principal (177,5)	Hauptdüse (177,5)	Chiclé máximo (177,5)	
	20	8H00 A1804	1	Getto minimo (25)	Idle jet (25)	Gicleur minimum (25)	Leerlaufdüse (25)	Chiclé mínimo (25)	
	20	8G00 A1804	1	Getto minimo (27,5)	Idle jet (27,5)	Gicleur minimum (27,5)	Leerlaufdüse (27,5)	Chiclé mínimo (27,5)	
	20	8000 A1804	1	Getto minimo (30)	Idle jet (30)	Gicleur minimum (30)	Leerlaufdüse (30)	Chiclé mínimo (30)	
	20	8A00 A1804	1	Getto minimo (32,5)	Idle jet (32,5)	Gicleur minimum (32,5)	Leerlaufdüse (32,5)	Chiclé mínimo (32,5)	
	20	8B00 A1804	1	Getto minimo (35)	Idle jet (35)	Gicleur minimum (35)	Leerlaufdüse (35)	Chiclé mínimo (35)	
	21	8A00 A1806	1	Polverizzatore (P 3)	Fuel nozzle (P 3)	Pulvérisateur (P 3)	Einspritzdüse (P 3)	Pulverizador (P 3)	
	21	8B00 A1806	1	Polverizzatore (P 5)	Fuel nozzle (P 5)	Pulvérisateur (P 5)	Einspritzdüse (P 5)	Pulverizador (P 5)	
	22	8A00 A1809	1	Getto pompa (35)	Pump jet (35)	Gicleur pompe (35)	Pumpendüse (35)	Chiclé bomba (35)	

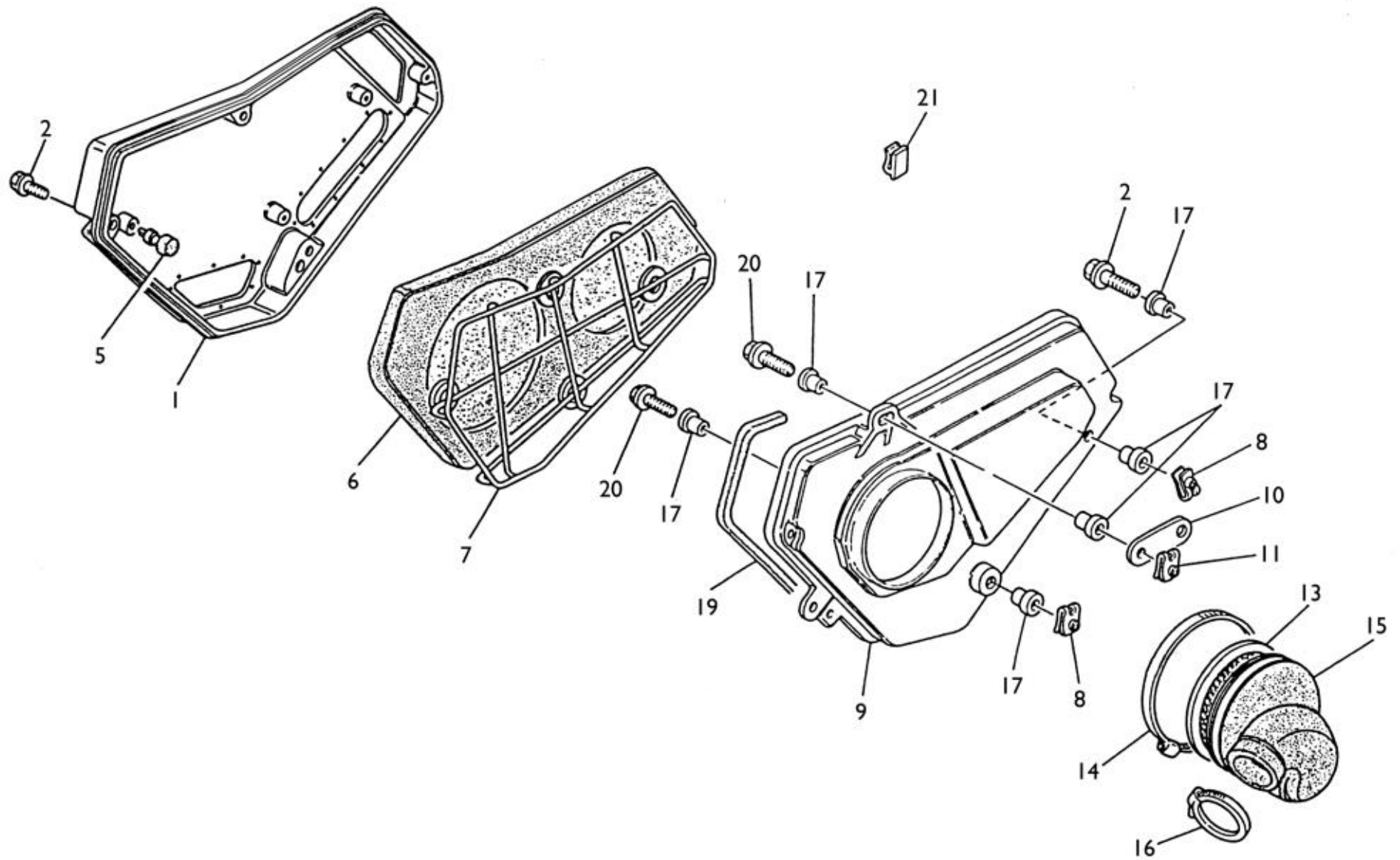

Note Notes Notes Marke Notas	Pos. No. N. Index Pos.	N. Cod. Code No. Nr. Code Code Nr N. Cod.	Q.tà Q.ty Q.te M.ge C.ad	DENOMINAZIONE	NAME	DESIGNATION	BESHREIBUNG	DENOMINACION	Validità Validity Validité Gültig Validez
W	1	8000 92946	1	Coperchio	Cover	Couvercle	Deckel	Tapa	
M	1	8000 92946	1	Coperchio (codice colore E)	Cover (color code E)	Couvercle (code couleur E)	Deckel (Code Farbe E)	Tapa (còdigo colòr E)	
M	1	80A0 92946	1	Coperchio (codice colore G)	Cover (color code G)	Couvercle (code couleur G)	Deckel (Code Farbe G)	Tapa (còdigo colòr G)	
	2	8000 62727	3	Vite (M6X16 mm)	Screw (M6X16 mm)	Vis (M6X16 mm)	Schraube (M6X16 mm)	Tornillo (M6X16 mm)	
	5	8000 67970	4	Tampone	Pad	Tampon	Stopfen	Tampón	
E	6	8000 69783	1	Filtro aria	Air filter	Filtre à air	Luftfilter	Filtro aire	
	6	8000 92948	1	Filtro aria	Air filter	Filtre à air	Luftfilter	Filtro aire	
	7	8000 92947	1	Gabbia filtro	Cleaner cage	Cage pour filtre	Filterkafig	Caja filtro	
	8	8000 46893	2	Dado	Nut	Ecrou	Mutter	Tuerca	
W	9	80A0 75671	1	Scatola filtro	Air filter box	Boîte filtre	Filterkasten	Caja filtro aire	
M	9	80A0 75671	1	Scatola filtro (codice colore E)	Air filter box (color code E)	Boîte filtre (code couleur E)	Filterkasten (Code Farbe E)	Caja filtro aire (còdigo colòr E)	
EM	9	8000 75671	1	Scatola filtro (codice colore G)	Air filter box (color code G)	Boîte filtre (code couleur G)	Filterkasten (Code Farbe G)	Caja filtro aire (còdigo colòr G)	
M	9	80A0 75671	1	Scatola filtro (codice colore G)	Air filter box (color code G)	Boîte filtre (code couleur G)	Filterkasten (Code Farbe G)	Caja filtro aire (còdigo colòr G)	
	10	1515 80301	1	Piastrina	Plate	Plaquette	Plättchen	Placa	
	11	8000 46893	1	Dado a graffetta	Nut	Ecrou	Mutter	Tuerca	
	13	8000 75673	1	Protezione	Guard	Protection	Schutz	Protección	
	14	8F00 99475	1	Fascetta	Clamp	Collier	Schelle	Banda	
	15	8000 75672	1	Raccordo	Union	Raccord	Anschluss	Empalme	
	16	8E00 99475	1	Fascetta	Clamp	Collier	Schelle	Banda	
	17	8000 45495	6	Bussola	Bushing	Douille	Buchse	Manguito	
	19	8A00 60652	1	Guarnizione	Gasket	Garnitue	Dichtung	Junta	
	20	8000 62728	3	Vite (M6X20 mm)	Screw (M6X20 mm)	Vis (M6X20 mm)	Schraube (M6X20 mm)	Tornillo (M6X20 mm)	
	21	8000 56806	1	Gancio adesivo	Hook	Crochet	Haken	Gancho	

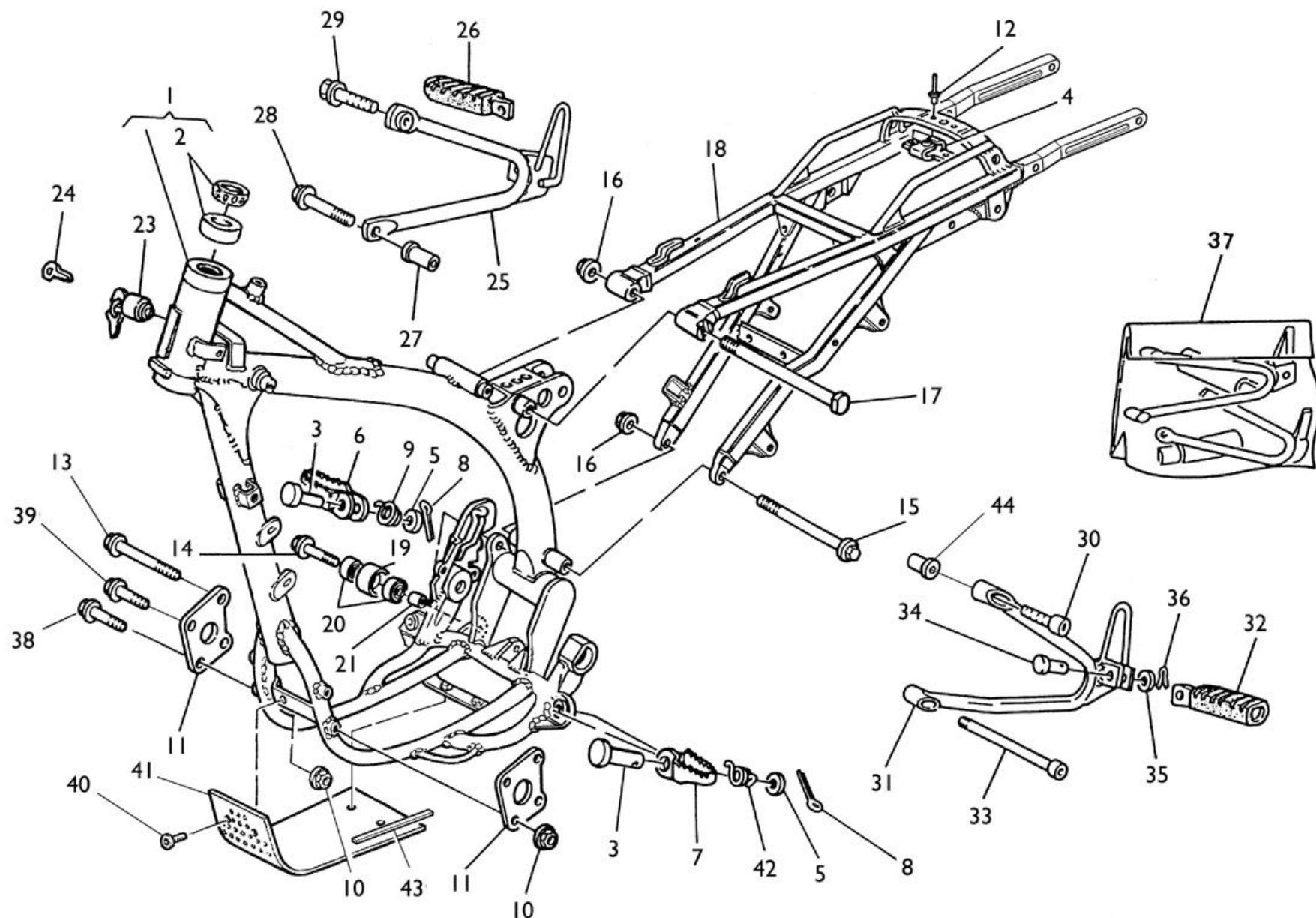

Note Notes Marka Notas	Pos. No. Index Pos.	N. Cod. Code No. Nr. Code Code Nr N. Cod.	Q.tà Q.ty Q.te M.ge C.ad	DENOMINAZIONE	NAME	DESIGNATION	BESHREIBUNG	DENOMINACION	Validità Validity Validité Gültig Validez
W	1	8A00 96975	1	Telaio	Frame	Chassis	Rahmen	Bastidor	
U	1	8C00 96975	1	Telaio	Frame	Chassis	Rahmen	Bastidor	
M	1	8G00 96975	1	Telaio	Frame	Chassis	Rahmen	Bastidor	
M	1	8J00 96975	1	Telaio (USA)	Frame (USA)	Chassis (USA)	Rahmen (USA)	Bastidor (USA)	
	2	1513 07001	2	Cuscinetto a rulli conici (ø25xØ50x17,5 mm)	Bearing (ø25xØ50x17,5 mm)	Roulement à roulewux coniq. (ø25xØ50x17,5 mm)	Lager (ø25xØ50x17,5 mm)	Cojinete de rodillos cónicos (ø25xØ50x17,5 mm)	
	3	8000 73140	2	Perno	Pin	Pivot	Bolzen	Perno	
	4	8000 69150	1	Piastrina	Plate	Plaquette	Plättchen	Placa	
	5	8A00 01815	2	Rosetta	Washer	Rondelle	Scheibe	Arandela	
	6	80A0 89953	1	Poggiapiedi Dx.	R.H. foot rest support	Support repose pied D.	R., Fussraster	Prisioneros derech. compl.	
	7	80A0 89962	1	Poggiapiedi Sx.	L.H. foot rest support	Support repose pied G.	L., Fussraster	Prisioneros compl.	
	8	64NI 20068	2	Copiglia	Split pin	Goupille	Splint	Clavija	
	9	8000 96908	1	Molla Dx	R.H. spring	Ressort D.	Feder Rechte	Resorte der.	
	10	80B0 43928	6	Dado	Nut	Ecrou	Mutter	Tuerca	
	11	8000 84665	2	Piastra motore	Motor plate	Plaquette moteur	Motorplättchen	Placa motor	
	12	8000 33373	2	Rivetto	Rivet	Rivet	Niet	Remache	
	13	8000 80277	2	Vite (M8x95 mm)	Screw (M8x95 mm)	Vis (M8x95 mm)	Schraube (M8x95 mm)	Tornillo (M8x95 mm)	
	14	8000 62796	2	Vite (M8x40 mm)	Screw (M8x40 mm)	Vis (M8x40 mm)	Schraube (M8x40 mm)	Tornillo(M8x40 mm)	
	15	8C00 69112	1	Vite (M8x145 mm)	Screw (M8x145 mm)	Vis (M8x145 mm)	Schraube (M8x145 mm)	Tornillo (M8x145 mm)	
	16	8000 43928	2	Dado	Nut	Ecrou	Mutter	Tuerca	
	17	8000 69111	1	Vite (M8x130 mm)	Screw (M8x130 mm)	Vis (M8x130 mm)	Schraube (M8x130 mm)	Tornillo (M8x130 mm)	
	18	8000 A0349	1	Telaio posteriore	Rear frame side	Chassis arrière	Sattelbrücke	Cuadro posterior	
	19	8000 59433	2	Rullo	Roller	Aiguille	Rolle	Rodillo	
	20	8000 63312	4	Cuscinetto (ø8xØ22x7 mm)	Bearing (ø8xØ22x7 mm)	Roulement (ø8xØ22x7 mm)	Lager (ø8xØ22x7 mm)	Cojinete (ø8xØ22x7 mm)	
	21	8000 59434	2	Distanziale	Spacer	Entretoise	Distanzstück	Separador	
XY	23	8000 43391	1	Serratura antifurto	Anti-left lock assy	Serrure anti-vol compl.	Sicherheitsschloss kpl.	Cerradura compl.	
XY	24	8000 35531	1	Chiave grezza	Raw key	Clef primitive	Schlüssel	Llave	
XYD	25	8000 97747	1	Supp. poggiapiedi Passegg. Dx.	Support	Support	Halterung	Soporte elástico	
XYD	26	8000 66652	1	Poggiapiedi passeggero Dx.	R.H. foot rest support	Support repose pied D.	R., Fussraster	Prisioneros derech. compl.	
XYD	27	8000 67724	1	Distanziale	Spacer	Entretoise	Distanzstück	Separador	
XYD	28	8A00 62797	1	Vite	Screw	Vis	Schraube	Tornillo	

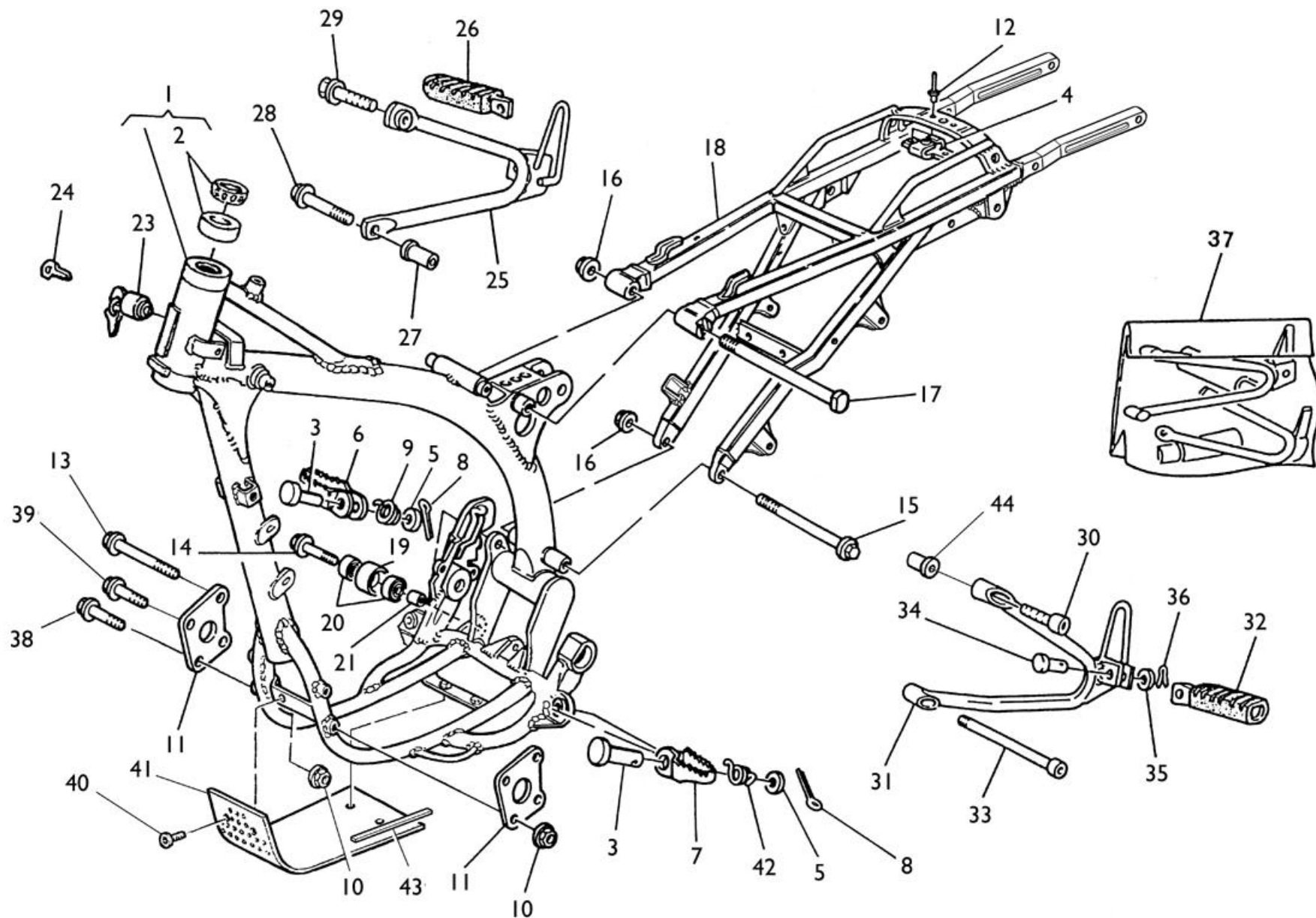

Note Notes Marka Notas	Pos. No. N. Index Pos.	N. Cod. Code No. Nr. Code Code Nr N. Cod.	Q.tà Q.ty Q.te M.ge C.ad	DENOMINAZIONE	NAME	DESIGNATION	BESHREIBUNG	DENOMINACION	Validità Validity Validité Gültig Validez
XYD	29	8000 69056	2	Vite	Screw	Vis	Schraube	Tornillo	
XYD	30	8000 69056	1	Vite	Screw	Vis	Schraube	Tornillo	
XYD	31	8000 A1910	1	Supp. poggiapiedi passegg. Sx.	Support	Support	Halterung	Soporte elástico	
XYD	32	8000 66651	1	Poggiapiedi passeggero Sx.	L.H. foot rest support	Support repose pied G.	L., Fussraster	Prisioneros compl.	
XYD	33	8000 56909	1	Vite	Screw	Vis	Schraube	Tornillo	
XYD	34	8000 41459	2	Perno	Pin	Pivot	Bolzen	Perno	
XYD	35	62NI 15504	2	Rosetta piana	Washer	Rondelle	Scheibe	Arandela	
XYD	36	64NI 20048	2	Copiglia	Split pin	Goupille	Splint	Clavija	
XYD	37	8A00 A1911	1	Kit poggiapiedi passeggero	L.H. foot rest support kit	Gr. support repose pied G.	L., Fussraster Gruppe	Kit prisioneros compl.	
	38	8E00 69056	2	Vite (M8x55 mm)	Screw (M8x55 mm)	Vis (M8x55 mm)	Schraube (M8x55 mm)	Tornillo (M8x55 mm)	
	39	8I00 69056	2	Vite (M8x60 mm)	Screw (M8x50 mm)	Vis (M8x50 mm)	Schraube (M8x50 mm)	Tornillo (M8x50 mm)	
	40	8000 60898	4	Vite	Screw	Vis	Schraube	Tornillo	
	41	8000 88143	1	Paramotore	Engine guard	Garde moteur	Motorschutz	Para motor	
	42	8000 96907	1	Molla Sx	L.H. spring	Ressort G.	Feder Linke	Resorte iz.	
	43	8000 29043	2	Spessore elastico	Rubber	Pièce caoutchoùc	Gummistück	Junta de goma	
XYD	44	80B0 43928	1	Dado	Nut	Ecrou	Mutter	Tuerca	

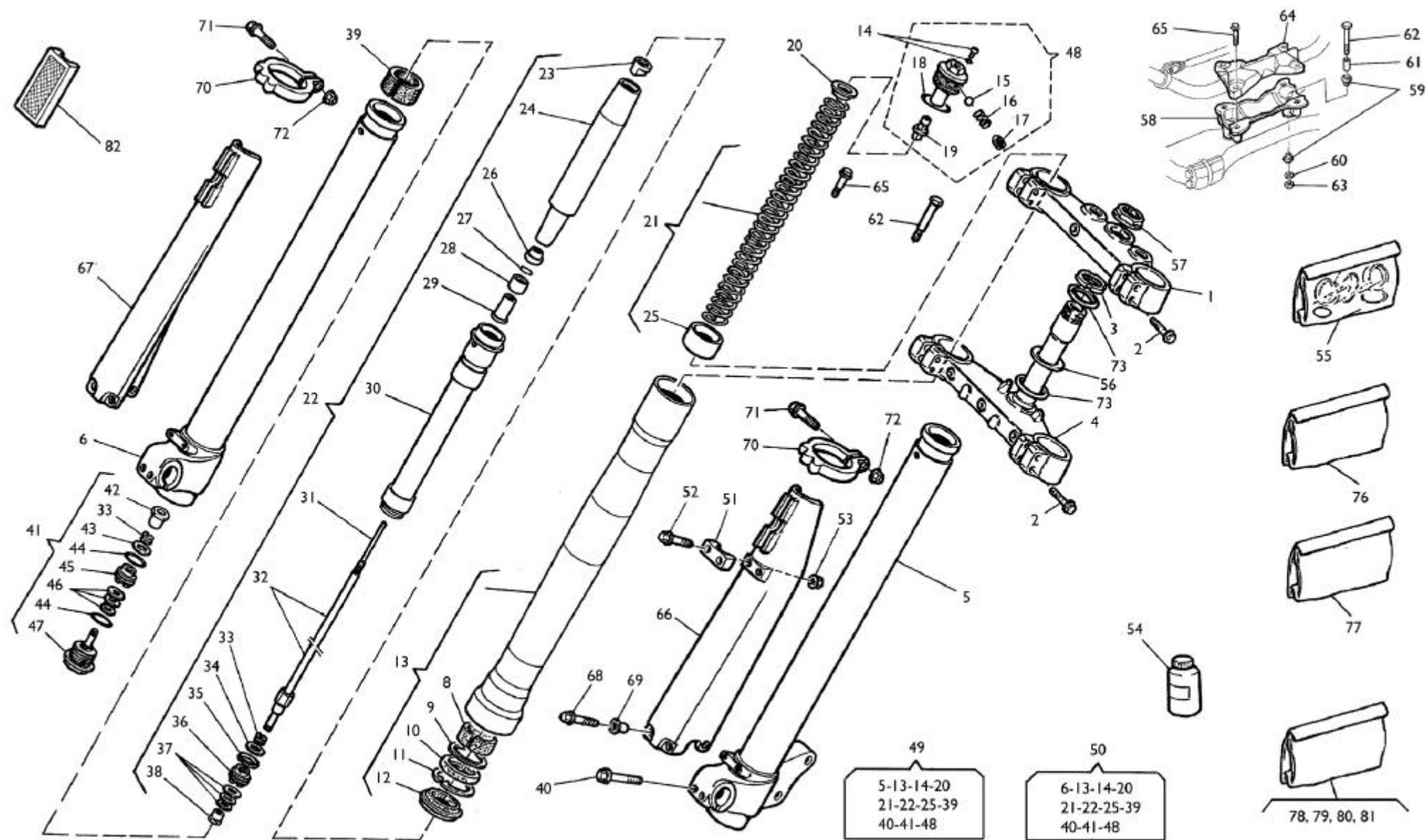

Note Notes Marke Notas	Pos. No. N. Index Pos.	N. Cod. Code No. Nr. Code Code Nr N. Cod.	Q.tà Q.ty Q.te M.ge C.ad	DENOMINAZIONE	NAME	DESIGNATION	BESHREIBUNG	DENOMINACION	Validità Validity Validité Gültig Validez
W	1	8A00 96811	1	Testa di sterzo	Steering head	Tête direction	Lenkkopf	Cabezal de dirección	
M	1	8000 95703	1	Testa di sterzo	Steering head	Tête direction	Lenkkopf	Cabezal de dirección	
	2	8000 62796	8	Vite (M8x40 mm)	Screw (M8x40 mm)	Vis (M8x40 mm)	Schraube (M8x40 mm)	Tornillo (M8x40 mm)	
	3	8000 83395	1	Ghiera registro cuscinetti	Ring nut	Embout	Nutmutter	Virol	
W	4	8000 96897	1	Base di sterzo con perno	Steering crown with pin	Socle de direction avec pivot	Gabelbrücke mit Bolzen	Base de dirección con perno	
M	4	8000 95702	1	Base di sterzo con perno	Steering crown with pin	Socle de direction avec pivot	Gabelbrücke mit Bolzen	Base de dirección con perno	
W	5	8000 98787	1	Stelo Sx. compl.	L.H. slider assy	Montant G. compl.	Bein, Kpl. L.	Deslizable izrda. compl.	
M	5	8000 96643	1	Stelo Sx. compl.	L.H. slider assy	Montant G. compl.	Bein, Kpl. L.	Deslizable izrda. compl.	
W	6	8000 98786	1	Stelo Dx. compl.	R.H. slider assy	Montant D. compl.	Bein, Kpl. R.	Deslizable der. compl.	
M	6	8000 91506	1	Stelo Dx. compl.	R.H. slider assy	Montant D. compl.	Bein, Kpl. R.	Deslizable der. compl.	
N	8	(a), (b)	2	Bussola	Bushing	Douille	Buchse	Manguito	
N	9		2	Scodellino	Cup	Cuvette	Teller	Cubeta	
N	10	(a), (c)	2	Anello di tenuta	Seal ring	Bague de retenue	Dichtring	Anillo de retención	
N	11	(c)	2	Anello di fermo	Stop ring	Bague d'arrêt	Haltering	Anillo de retención	
N	12	(a), (c)	2	Raschiapolvere	Dust scraper	Racloir poudre	Pulverabschaber	Rascador de polvo	
	13	8000 91474	2	Portastelo completo	Pipe assy	Groupe tuyau compl.	Rohrgruppe Kpl	Grupo tubo compl.	
N	14		2	Vite	Screw	Vis	Schraube	Tornillo	
N	15		2	Sfera	Ball	Bille	Kugel	Esfera	
N	16		2	Molla per sfera	Spring	Ressort	Feder	Resorte	
N	17		2	Grano filettato	Dowel	Grain	Stift	Pasadør	
N	18	(a)	2	Anello OR	O-Ring	Bague OR	O-Ring	Anillo OR	
	19	8000 91479	2	Gruppo registro	Adjuster set	Groupe reglage	Reglergruppe	Grupo regulaciòn	
	20	8000 77373	2	Scodellino	Cup	Cuvette	Teller	Cubeta	
W	21	8000 91610	1	Kit molla (k= 4,5 N/mm)	Spring (k= 4,5 N/mm)	Ressort (k= 4,5 N/mm)	Feder (k= 4,5 N/mm)	Resorte (k= 4,5 N/mm)	
M	21	8000 98803	1	Kit molla (k= 5,0 N/mm)	Spring (k= 5,0 N/mm)	Ressort (k= 5,0 N/mm)	Feder (k= 5,0 N/mm)	Resorte (k= 5,0 N/mm)	
W	22	8000 98552	2	Gruppo pompante compl.	Damping element compl.	Amortissement compl.	Schwingungsdämpfer Kpl.	Bombeadora compl.	
M	22	8000 96645	2	Gruppo pompante compl.	Damping element compl.	Amortissement compl.	Schwingungsdämpfer Kpl.	Bombeadora compl.	
N	23		2	Dado	Nut	Ecrou	Mutter	Tuerca	
N	24		2	Guidamolla	Spring guide	Guide ressort	Federführung	Guia resorte	

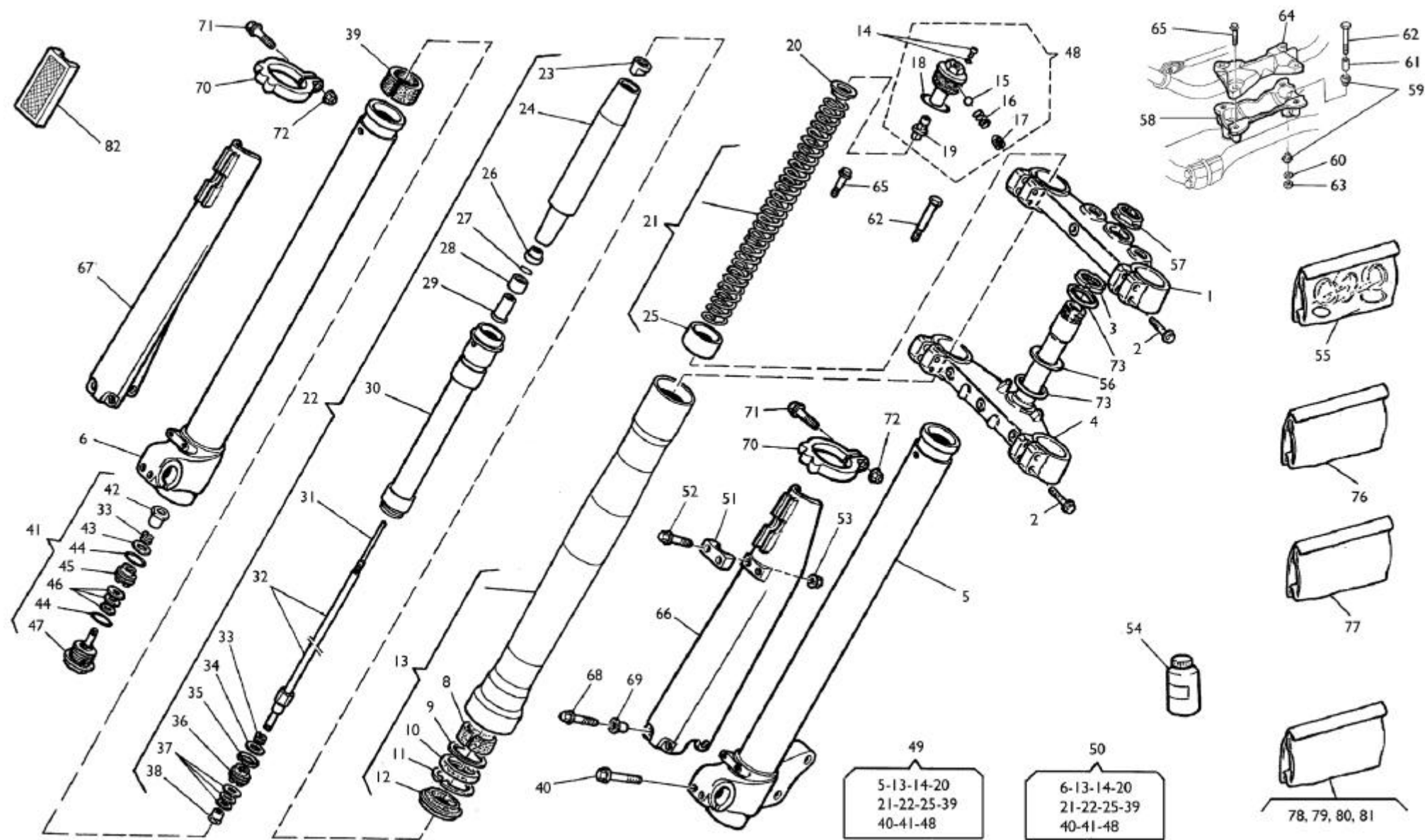

Note Notes Marka Notas	Pos. No. N. Index Pos.	N. Cod. Code No. Nr. Code Code Nr N. Cod.	Q.tà Q.ty Q.te M.ge C.ad	DENOMINAZIONE	NAME	DESIGNATION	BESHREIBUNG	DENOMINACION	Validità Validity Validité Gültig Validez
N	25		2	Tubetto	Pipe	Tuyau	Rohr	Tubo	
N	26		2	Dado	Nut	Ecrou	Mutter	Tuerca	
N	27		2	Anello SEEGER	SEEGER ring	Anneau SEEGER	SEEGER Ring	Anillo SEEGER	
N	28		2	Tampone di fondo	Pad	Tampon	Stopfen	Tampòn	
N	29		2	Distanziale	Spacer	Entretoise	Distanzstück	Separadòr	
N	30		2	Custodia	Housung	Cage	Korb	Custodia	
N	31		2	Asta interna	Internal rod	Barre	Stange	Varilla	
N	32		2	Ass. asta	Rod assy	Barre compl.	Stange Kpl	Grupo varilla	
N	33		4	Molla	Spring	Ressort	Feder	Resorte	
N	34	(d)	2	Lamella	Plate	Lamelle	Plättchen	Laminilla	
N	35	(a)	2	Segmento	Circlip	Segment	Colbenring	Segmento	
N	36		2	Pistone estensione	R.H. piston	Piston D.	Kolbe R.	Pistón der.	
N	37	(d)	6	Lamella	Plate	Lamelle	Plättchen	Laminilla	
N	38		2	Dado	Nut	Ecrou	Mutter	Tueca	
N	39	(a), (b)	2	Bussola	Bushing	Douille	Buchse	Manguito	
	40	8000 62729	4	Vite (M6x25 mm)	Screw (M6x25 mm)	Vis (M6x25 mm)	Schraube (M6x25 mm)	Tornillo (M6x25 mm)	
W	41	8000 98781	2	Ass. valvola di fondo	Valve	Soupape	Ventil	Válvula	
M	41	8000 96647	2	Ass. valvola di fondo	Valve	Soupape	Ventil	Válvula	
N	42		2	Dado	Nut	Ecrou	Mutter	Tuerca	
N	43	(d)	2	Lamella	Plate	Lamelle	Plättchen	Laminilla	
N	44	(a)	2	Anello OR	O-Ring	Bague OR	O-Ring	Anillo OR	
N	45		2	Pistone compressione	Piston	Piston	Kolbe	Pistón	
N	46	(d)	6	Lamella	Plate	Lamelle	Plättchen	Laminilla	
N	47		2	Valvola	Valve	Soupape	Ventil	Valvula	
	48	8000 91480	2	Gruppo tappo	Plug assy	Groupe bouchon	Verschlussgruppe Kpl	Grupo tapón	
W	49	8A00 97015	1	Gamba Sx. compl.	L.H. fork leg assy	Fourche complete G.	Telegabel Kpl. L.	Horquilla izrda. compl.	
M	49	8000 95699	1	Gamba Sx. compl.	L.H. fork leg assy	Fourche complete G.	Telegabel Kpl. L.	Horquilla izrda. compl.	
W	50	8A00 97016	1	Gamba Dx. compl.	R.H. fork leg assy	Fourche complete D.	Telegabel Kpl. R.	Horquilla derech. compl.	
M	50	8000 95698	1	Gamba Dx. compl.	R.H. fork leg assy	Fourche complete D.	Telegabel Kpl. R.	Horquilla derech. compl.	

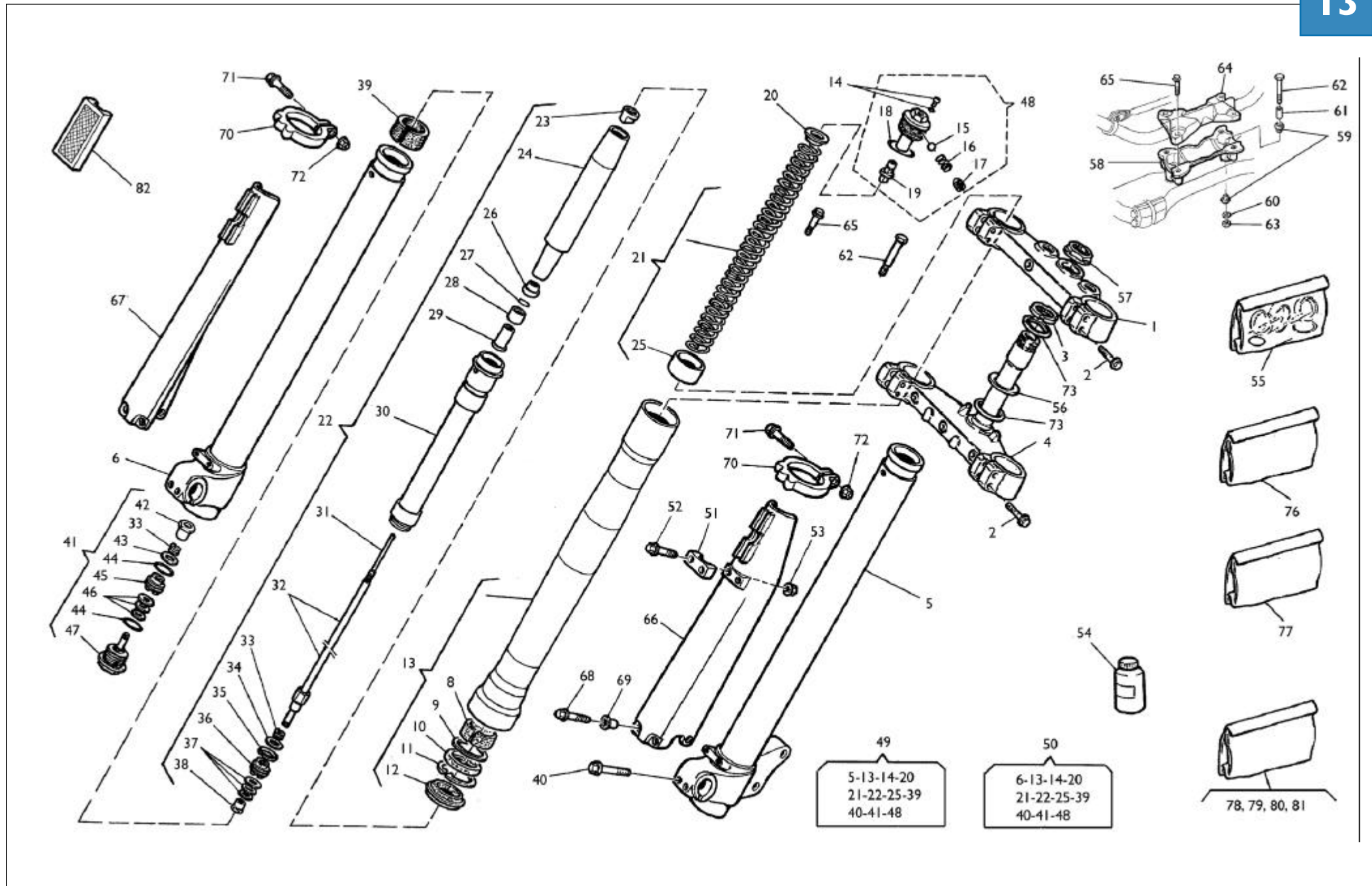

49
5-13-14-20
21-22-25-39
40-41-48

50
6-13-14-20
21-22-25-39
40-41-48

78, 79, 80, 81

Note Notes Marke Notas	Pos. No. N. Index Pos.	N. Cod. Code No. Nr. Code Code Nr N. Cod.	Q.tà Q.ty Q.te M.ge C.ad	DENOMINAZIONE	NAME	DESIGNATION	BESHREIBUNG	DENOMINACION	Validità Validity Validité Gültig Validez
W	51	8000 A0633	1	Piastrina	Plate	Plaquette	Plättchen	Placa	
M	51	8000 A0633	1	Piastrina (codice colore E)	Plate (color code E)	Plaquette (code couleur E)	Plättchen (Code Farbe E)	Placa (còdigo colòr E)	
M	51	80A0 A0633	1	Piastrina (codice colore G)	Plate (color code G)	Plaquette (code couleur G)	Plättchen (Code Farbe G)	Placa (còdigo colòr G)	
	52	8A00 67997	2	Vite	Screw	Vis	Schraube	Tornillo	
	53	8000 61355	2	Dado	Nut	Ecrou	Mutter	Tueca	
R	54	8000 80260	1	Olio forcella	Front fork oil	Huile fourche avant	Öl für die Vordergabel	Aceite horquilladelantera	
	55	8000 91519	1	Gruppo guarnizioni	Gasket set	Groupe garnitures	Dichtungsatz	Grupo juntas	
WM	56	8A00 65503	2	Rosetta piana	Washer	Rondelle	Scheibe	Arandela	
WM	57	8000 69315	1	Dado	Nut	Ecrou	Mutter	Tuerca	
	58	8000 98237	1	Mozzetto inferiore	Hub	Moyeau	Radnabe	Cbo	
	59	8000 60233	4	Gommino	Rubber pad	Pièce caoutchouc	Gummistück	Junta de goma	
	60	8000 60234	2	Rosetta piana	Washer	Rondelle	Scheibe	Arandela	
	61	8000 53155	2	Distanziale	Spacer	Entretoise	Distanzstück	Separador	
	62	60N1 01219	2	Vite (M10x65 mm)	Screw(M10x65 mm)	Vis(M10x65 mm)	Schraube(M10x65 mm)	Tornillo(M10x65 mm)	
	63	8000 61314	2	Dado	Nut	Ecrou	Mutter	Tuerca	
	64	8000 98118	2	Mozzetto superiore	Hub	Moyeau	Radnabe	Cubo	
	65	8C00 69056	4	Vite (M8x30 mm)	Screw (M8x30 mm)	Vis (M8x30 mm)	Schraube (M8x30 mm)	Tornillo (M8x30 mm)	
W	66	80G0 69337	1	Protezione steli Sx.	Guard L.H.	Protection D.	Schutz L.	Protección izq.	
M	66	80A0 95696	1	Protezione steli Sx. (codice colore E)	Guard L.H. (color code E)	Protection D. (code couleur E)	Schutz L. (Code Farbe E)	Protección izq. (còdigo colòr E)	
M	66	8000 95696	1	Protezione steli Sx. (codice colore G)	Guard L.H. (color code G)	Protection D. (code couleur G)	Schutz L. (Code Farbe G)	Protección izq. (còdigo colòr G)	
W	67	80G0 69338	1	Protezione steli Dx.	Guard R.H.	Protection G.	Schutz R.	Protección der.	
M	67	80G0 69338	1	Protezione steli Dx. (codice colore E)	Guard R.H. (color code E)	Protection G. (code couleur E)	Schutz R. (Code Farbe E)	Protección der. (còdigo colòr E)	
M	67	80C0 69338	1	Protezione steli Dx. (codice colore G)	Guard R.H. (color code G)	Protection G. (code couleur G)	Schutz R. (Code Farbe G)	Protección der. (còdigo colòr G)	
	68	8000 67997	6	Vite	Screw	Vis	Schraube	Tornillo	
	69	8000 69282	6	Bussola	Bush	Douille	Buchse	Manguito	

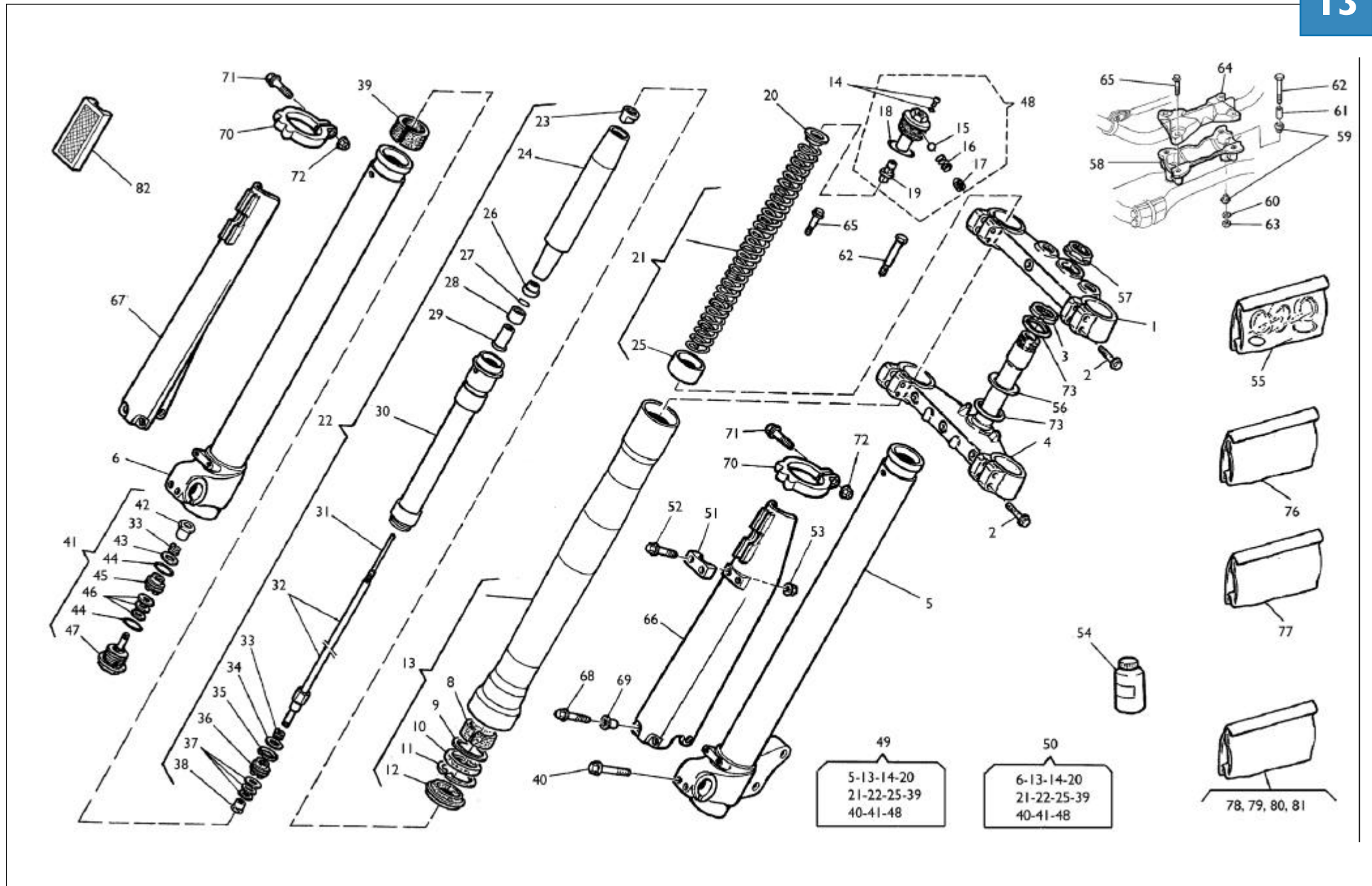

Note Notes Marka Notas	Pos. No. N. Index Pos.	N. Cod. Code No. Nr. Code Code Nr N. Cod.	Q.tà Q.ty M.ge C.ad	DENOMINAZIONE	NAME	DESIGNATION	BESHREIBUNG	DENOMINACION	Validità Validity Validité Gültig Validez
W	70	8000 93283	2	Anello	Ring	Bague	Ring	Anilo	
M	70	80A0 70558	2	Anello	Ring	Bague	Ring	Anilo	
	71	8B00 66525	2	Vite	Screw	Vis	Schraube	Tornillo	
	72	8000 56443	2	Dado	Nut	Ecrou	Mutter	Tuerca	
	76	8000 97750	1	Kit boccole	Bush kit	Kit douille	Buchsekit	Kit manguito	
	77	8000 97749	1	Kit anelli di tenuta	Seal ring kit	Kit bague de retenue	Dichtringkit	Kit anillo de retención	
	78	8000 98782	1	Kit lamelle (0,1 mm)	Plate kit (0,1 mm)	Kit lamelle (0,1 mm)	Plättchenkit (0,1 mm)	Kit Laminilla (0,1 mm)	
	79	8000 98783	1	Kit lamelle (0,2 mm)	Plate kit (0,2 mm)	Kit lamelle (0,2 mm)	Plättchenkit (0,2 mm)	Kit Laminilla (0,2 mm)	
	80	8000 98784	1	Kit lamelle (0,3 mm)	Plate kit (0,3 mm)	Kit lamelle (0,3 mm)	Plättchenkit (0,3 mm)	Kit Laminilla (0,3 mm)	
	81	8000 98785	1	Kit lamelle (0,4 mm)	Plate kit (0,4 mm)	Kit lamelle (0,4 mm)	Plättchenkit (0,4 mm)	Kit Laminilla (0,4 mm)	
	82	80B0 73832	2	Catadiottro (AUS, CDN)	Reflector (AUS, CDN)	Catadioptrique (AUS, CDN)	Rückstrahler (AUS, CDN)	Catafaros (AUS, CDN)	
a				Forniti anche in gruppo pos. 55	Supplied in bag ref. N° 55	Son fournies en unités pos. 55	Sind im Umschlag Bez. Nr 55	Provisto en grupo pos. 55	
b				Forniti anche in gruppo pos. 76	Supplied in bag ref. N° 76	Son fournies en unités pos. 76	Sind im Umschlag Bez. Nr 76	Provisto en grupo pos. 76	
c				Forniti anche in gruppo pos. 77	Supplied in bag ref. N° 77	Son fournies en unités pos. 77	Sind im Umschlag Bez. Nr 77	Provisto en grupo pos. 77	
d				Forniti anche in gruppo pos. 78, 79, 80, 81	Supplied in bag ref. N° 78, 79, 80, 81	Son fournies en unités pos. 78, 79, 80, 81	Sind im Umschlag Bez. Nr 78, 79, 80, 81	Provisto en grupo pos. 78, 79, 80, 81	

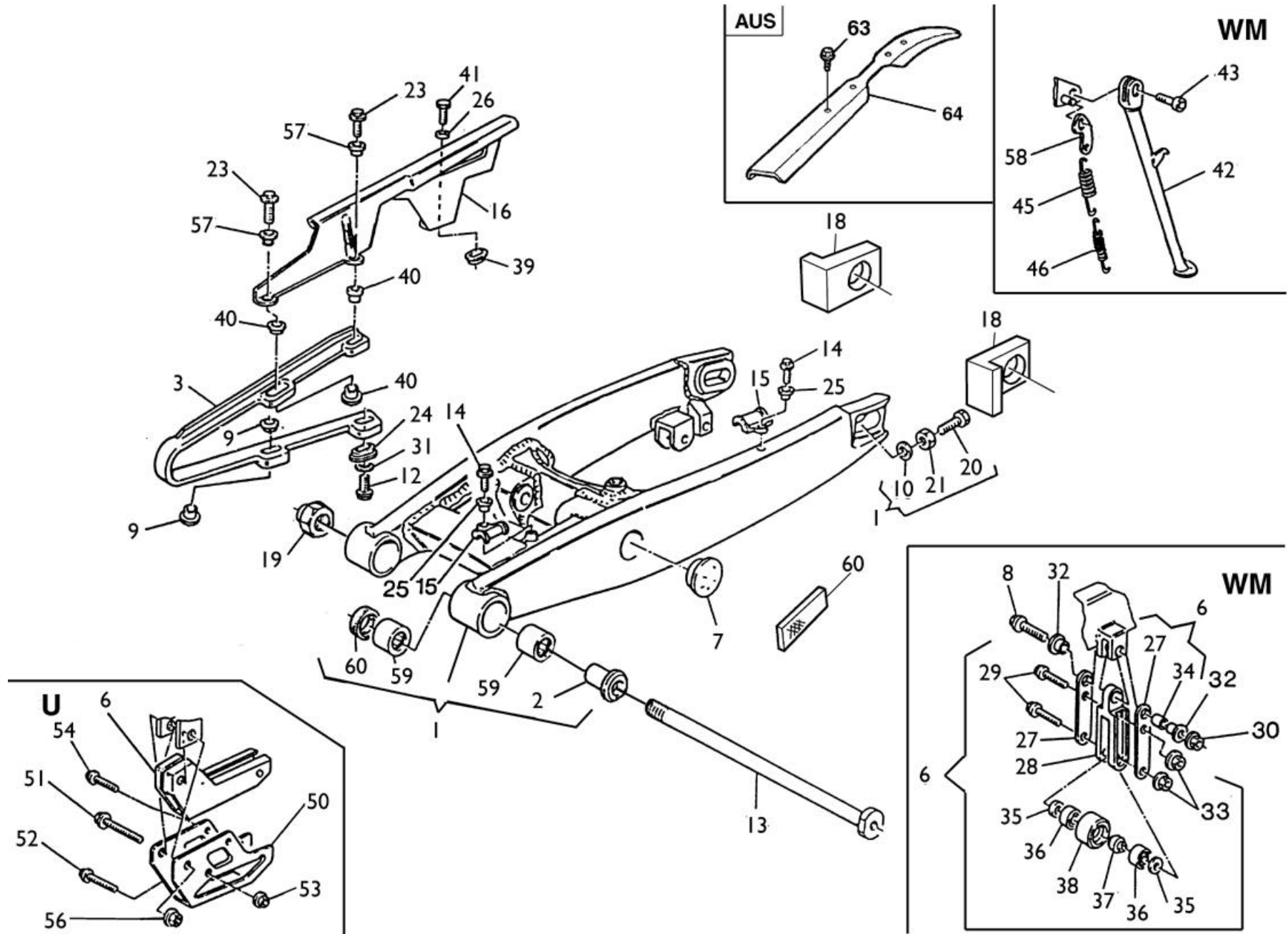

Note Notes Marke Notas	Pos. No. N. Index Pos.	N. Cod. Code No. Nr. Code Code Nr N. Cod.	Q.tà Q.ty Q.te M.ge C.ad	DENOMINAZIONE	NAME	DESIGNATION	BESHREIBUNG	DENOMINACION	Validità Validity Validité Gültig Validez
	1	8000 97059	1	Forcellone completo	Compl. fork	Fourche complete	Gabel, Kpl.	Horquilla compl.	
	2	8A00 83904	2	Bussola	Bushing	Douille	Buchse	Manguito	
	3	8000 72884	1	Pattino catena	Chain slider	Glissière	Gleitbahn	Plato catena	
WM	6	8000 72873	1	Guidacatena	Chain guide	Guide-chaîne	Kettenführung	Guía-cadena	
U	6	8000 72868	1	Guidacatena	Chain guide	Guide-chaîne	Kettenführung	Guía-cadena	
	7	80A0 74388	2	Tappo	Plug	Bouchon	Verschluss	Tapón	
Y	8	8000 62795	1	Vite	Screw	Vis	Schraube	Tornillo	
WM	9	8000 75166	2	Scodellino	Cup	Cuvette	Teller	Cubeta	
U	9	8000 75166	4	Scodellino	Cup	Cuvette	Teller	Cubeta	
	10	8000 08536	2	Rosetta	Washer	Rondelle	Scheibe	Arandela	
WM	12	8000 67997	2	Vite	Screw	Vis	Schraube	Tornillo	
U	12	8000 67997	4	Vite	Screw	Vis	Schraube	Tornillo	
	13	8000 71620	1	Perno forcellone	Fork pin	Pivot fourche	Gabelbolzen	Perno horquilla	
	14	8000 20536	2	Vite	Screw	Vis	Schraube	Tornillo	
	15	80A0 73456	2	Guidacavo	Cable guide	Guide câble	Kabelführung	Guía-cable	
XW	16	80A0 73426	1	Copricatena	Chain guard	Carter de chaîne	Kettenkasten	Cubre-cadena	
M	16	8AA0 73426	1	Copricatena	Chain guard	Carter de chaîne	Kettenkasten	Cubre-cadena	
	18	8000 96944	1	Tendicatena lato dado	Chain adjuster - nut side	Tendeur de chaîne côtés écrou	Kettenspanner Mutterseite	Tensor de cadena lato tuerca	
	18	8000 96941	1	Tendicatena lato perno	Chain adjuster - pin side	Tendeur de chaîne côtés pivot	Kettenspanner bolzenseite	Tensor de cadena lato perno	
	19	8000 71623	1	Dado	Nut	Ecrou	Mutter	Tuerca	
	20	8C00 61121	2	Vite	Screw	Vis	Schraube	Tornillo	
	21	8000 17810	2	Dado	Nut	Ecrou	Mutter	Tuerca	
XW	23	8C00 67997	2	Vite	Screw	Vis	Schraube	Tornillo	
WM	24	8000 59289	1	Scodellino	Cup	Cuvette	Teller	Cubeta	
U	24	8000 59289	2	Scodellino	Cup	Cuvette	Teller	Cubeta	
	25	8000 69282	2	Bussola	Bushing	Douille	Buchse	Manguito	
XY	26	8000 36137	1	Rosetta	Washer	Rondelle	Scheibe	Arandela	
Y	27	8000 72875	2	Lamiera guidacatena (XBR)	Chain guide (XBR)	Guide-chaîne (XBR)	Kettenführung (XBR)	Guía-cadena (XBR)	
Y	28	8000 72874	1	Piastra d'attacco	Plate	Plaque	Platte	Placa	
Y	29	8000 62731	2	Vite	Screw	Vis	Schraube	Tornillo	
Y	30	8000 43928	1	Dado	Nut	Ecrou	Mutter	Tuerca	

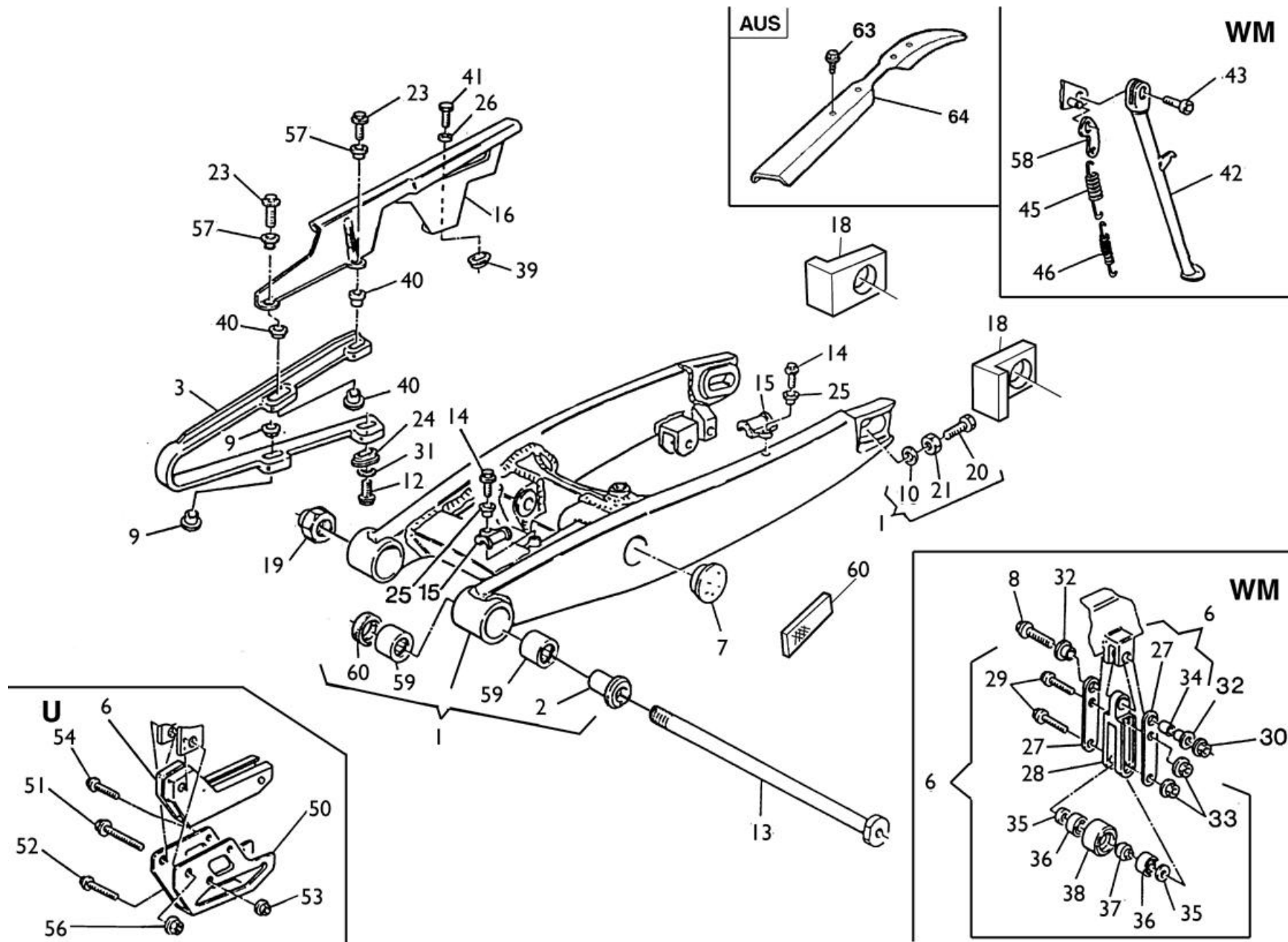

Note Notes Marke Notas	Pos. No. N. Index Pos.	N. Cod. Code No. Nr. Code Code Nr N. Cod.	Q.tà Q.ty Q.te M.ge C.ad	DENOMINAZIONE	NAME	DESIGNATION	BESHREIBUNG	DENOMINACION	Validità Validity Validité Gültig Validez
WM	31	8000 36137	2	Rosetta	Washer	Rondelle	Scheibe	Arandela	
U	31	8000 36137	4	Rosetta	Washer	Rondelle	Scheibe	Arandela	
Y	32	8A00 66661	1	Bussola	Bushing	Douille	Buchse	Manguito	
Y	33	8000 44240	2	Dado	Nut	Ecrou	Mutter	Tuerca	
Y	34	1515 50601	1	Bussola elastica	Bushing	Douille	Buchse	Manguito	
Y	35	8000 45495	2	Rosetta di spallamento	Washer	Rondelle	Scheibe	Arandela	
Y	36	8000 63312	2	Cuscinetto (ø8xØ22x7 mm)	Bearing (ø8xØ22x7 mm)	Roulement (ø8xØ22x7 mm)	Kugellager (ø8xØ22x7 mm)	Cojinete (ø8xØ22x7 mm)	
Y	37	8000 65412	1	Distanziale	Spacer	Entretoise	Distanzstück	Separador	
Y	38	8000 65411	1	Rullo guidacatena	Roller	Aiguille	Rolle	Rodillo	
XY	39	8000 59289	1	Scodellino	Cup	Cuvette	Teller	Cubeta	
XY	40	8000 75166	3	Scodellino	Cup	Cuvette	Teller	Cubeta	
XY	41	8000 20536	1	Vite	Screw	Vis	Schraube	Tornillo	
W	42	8B00 93066	1	Gamba laterale	Side stand	Bequille lat.	Seitenständer	Horquilla lateral	
M	42	8C00 93066	1	Gamba laterale	Side stand	Bequille lat.	Seitenständer	Horquilla lateral	
Y	43	8000 97977	1	Vite	Screw	Vis	Schraube	Tornillo	
WM	45	8000 94488	1	Molla esterna	Spring	Ressort	Feder	Resorte	
WM	46	8000 94489	1	Molla interna	Spring	Ressort	Feder	Resorte	
U	50	8000 72869	1	Staffa	Bracket	Etrier	Buegel	Brida	
U	51	8000 62795	1	Vite (M8x50 mm)	Screw (M8x50 mm)	Vis (M8x50 mm)	Schraube (M8x50 mm)	Tornillo (M8x50 mm)	
U	52	8000 62731	1	Vite (M6x45 mm)	Screw (M6x45 mm)	Vis (M6x45 mm)	Schraube (M6x45 mm)	Tornillo (M6x45 mm)	
U	53	8000 44240	1	Dado	Nut	Ecrou	Mutter	Tuerca	
U	54	8000 62725	1	Vite (M6x10 mm)	Screw (M6x10 mm)	Vis (M6x10 mm)	Schraube (M6x10 mm)	Tornillo (M6x10 mm)	
U	56	8000 43928	1	Dado	Nut	Ecrou	Mutter	Tuerca	
XY	57	8A00 69282	2	Distanziale	Spacer	Entretoise	Distanzstück	Separador	
W	58	8A00 62644	1	Piastrina	Plate	Plaquette	Plättchen	Placa	
	59	8000 76283	4	Gabbia a rulli	Needle cage	Cage à aiguilles	Nadelkäfig	Jaula de agujas del cojinete	
	60	8000 73832	2	Catadiottro (AUS, CDN)	Reflector (AUS, CDN)	Catadioptrique (AUS, CDN)	Rückstrahler (AUS, CDN)	Catafaros (AUS, CDN)	
	63	8000 81628	4	Vite (AUS)	Screw (AUS)	Vis (AUS)	Schraube (AUS)	Tornillo (AUS)	
	64	8000 A2352	1	Prolunga (AUS)	Guard(AUS)	Carter (AUS)	Kasten (AUS)	Protección (AUS)	

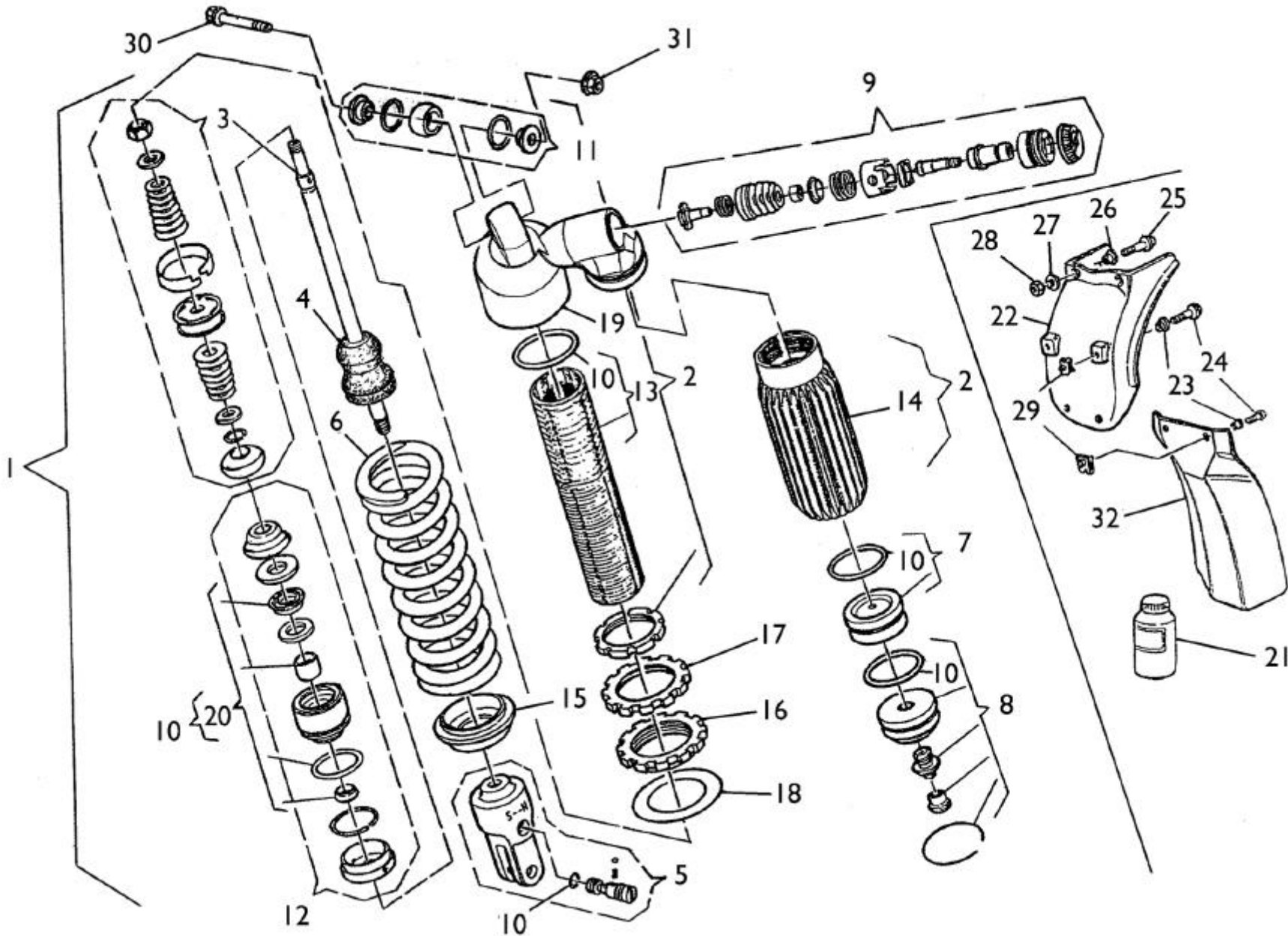

Note Notes Notas	Pos. No. N. Index Pos.	N. Cod. Code No. Nr. Code Code Nr N. Cod.	Q.tà Q.ty Q.te M.ge C.ad	DENOMINAZIONE	NAME	DESIGNATION	BESHREIBUNG	DENOMINACION	Validità Validity Validité Gültig Validez
W	1	8000 97049	1	Ammortizzatore completo	Shock-absorber	Ammortisseur	Stossdampfer	Amortigüador	
M	1	8000 97590	1	Ammortizzatore completo	Shock-absorber	Ammortisseur	Stossdampfer	Amortigüador	
	2	8000 98512	1	Gruppo corpo	Damper case assy	Groupe corps amortisseur	Stossdämpferkörper Kpl.	Corpo amortigüador compl.	
W	3	8000 98513	1	Gruppo stelo	Rod assy	Groupe tige	Pumpenstückgruppe	Grupo espiga	
M	3	8000 98519	1	Gruppo stelo	Rod assy	Groupe tige	Pumpenstückgruppe	Grupo espiga	
	4	8000 91238	1	Tampone	Pad	Tampon	Stopfen	Tampòn	
	5	8000 98489	1	Gruppo forcella	Fork assy	Groupe fourche	Gabelgruppe Kpl.	Grupo horquilla	
W	6	8000 98570	1	Molla (k=5,4 Kg/mm)	Spring (k=5,4 Kg/mm)	Ressort (k=5,4 Kg/mm)	Feder (k=5,4 Kg/mm)	Resorte (k=5,4 Kg/mm)	
M	6	8000 98520	1	Molla (k=6,4 Kg/mm)	Spring (k=6,4 Kg/mm)	Ressort (k=6,4 Kg/mm)	Feder (k=6,4 Kg/mm)	Resorte (k=6,4 Kg/mm)	
	7	8000 98490	1	Diaframma	Diaphragm	Diaphragme	Biegeplatte	Diafragma	
	8	8000 98491	1	Gruppo serbatoio	Tank assy	Groupe reservoir	Tankgruppe Kpl.	Grupo deposito compl.	
	9	8000 98492	1	Gruppo regolazione	Adjuster set	Groupe réglage	Reglergruppe Kpl.	Grupo regulacion	
	10	8000 98493	1	Gruppo guarnizioni	Gasket set	Groupe garnitures	Dichtungssatz	Grupo juntas	
	11	8000 89089	1	Gruppo snodo	Ball joint assy	Groupe joint a rotule	Kugelgelenkgruppe Kpl.	Grupo articulaciòn esferica	
	12	8000 98494	1	Gruppo guida stelo	Guide rod assy	Groupe guide tige	Pumpenstückführunggruppe	Grupo guja espiga	
	13	8000 98514	1	Corpo ammortizzatore	Damper case	Corps amortisseur	Stossdämpferkörper	Corpo amortigüador	
	14	8000 98515	1	Serbatoio	Tank	Reservoir	Tank	Deposito	
	15	8000 98496	1	Fondello	Bottom	Fond	Bodenscheibe	Casquilo	
	16	8000 98497	1	Ghiera	Ring nut	Embout	Nutmutter	Virola	
	17	8000 98498	1	Ghiera	Ring nut	Embout	Nutmutter	Virola	
	18	8000 98499	1	Rosetta per molla	Washer	Rondelle	Scheibe	Arandela	
	19	8000 98517	1	Supporto serbatoio	Tank support	Support reservoir	Gastankhalterung	Soporte deposito	
	20	8000 98495	1	Gruppo guarnizioni per stelo	Rod gasket set	Jeu joints pour tige	Dichtungs für Pumpenstock	Serie juntas por espiga	
R	21	8000 88231	1	Olio ammortizzatore	Shock-absorber oil	Huile amortisseur	Öl für Stossdampfer	Aceite amortigüador	
	22	8000 92961	1	Protezione ammortizzatore	Guard	Protection	Schutz	Protección	
	23	8000 69429	4	Bussola	Bushing	Douille	Buchse	Manguito	
	24	8000 62727	4	Vite	Screw	Vis	Schraube	Tornillo	
	25	8A00 67545	2	Vite	Screw	Vis	Schraube	Tornillo	
	26	8000 72268	2	Distanziale	Spacer	Entretoise	Distanzstück	Separador	
	27	8000 56359	2	Rosetta piana	Washer	Rondelle	Scheibe	Arandela	
	28	8000 44240	2	Dado	Nut	Ecrou	Mutter	Tuerca	

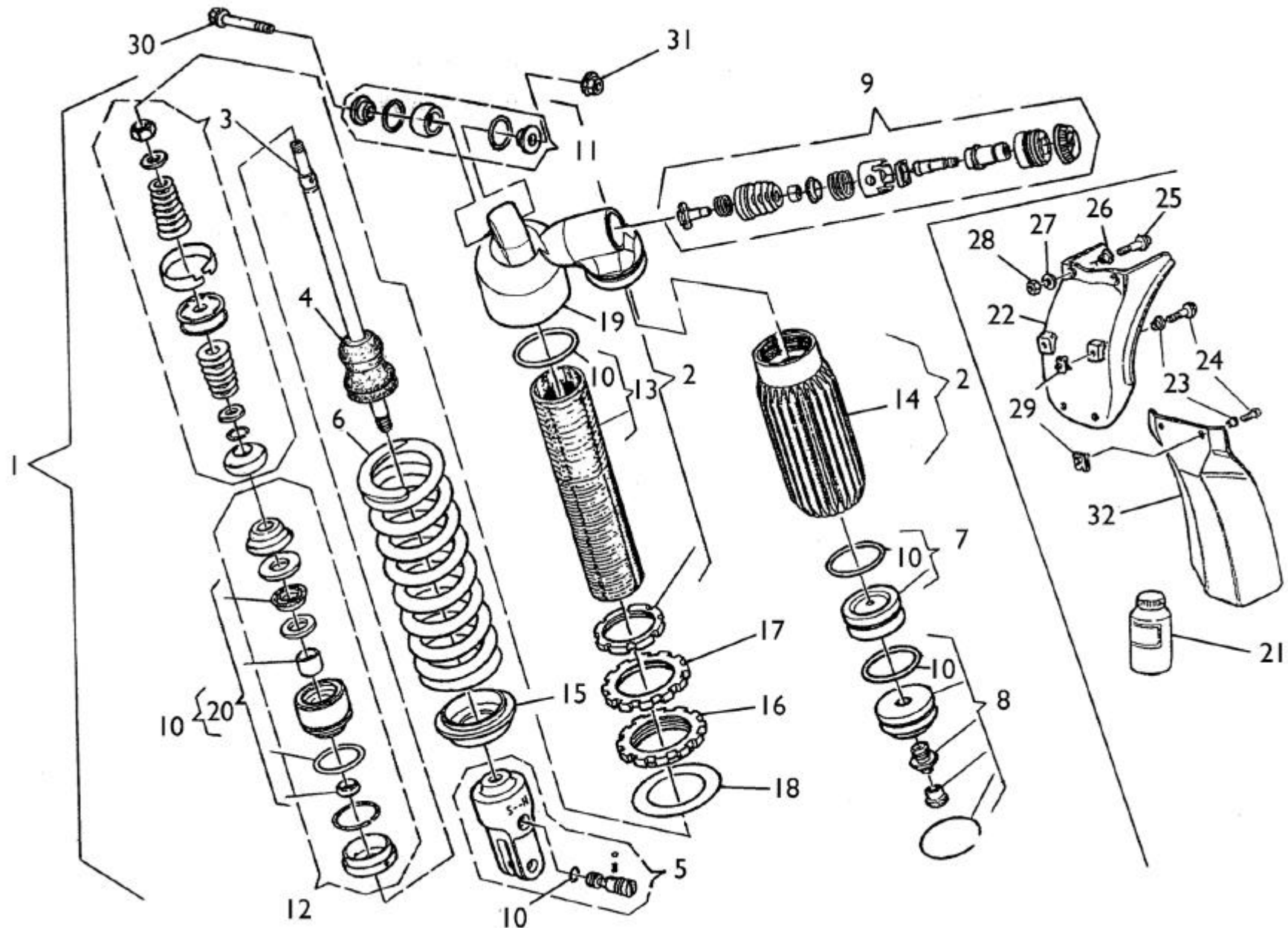

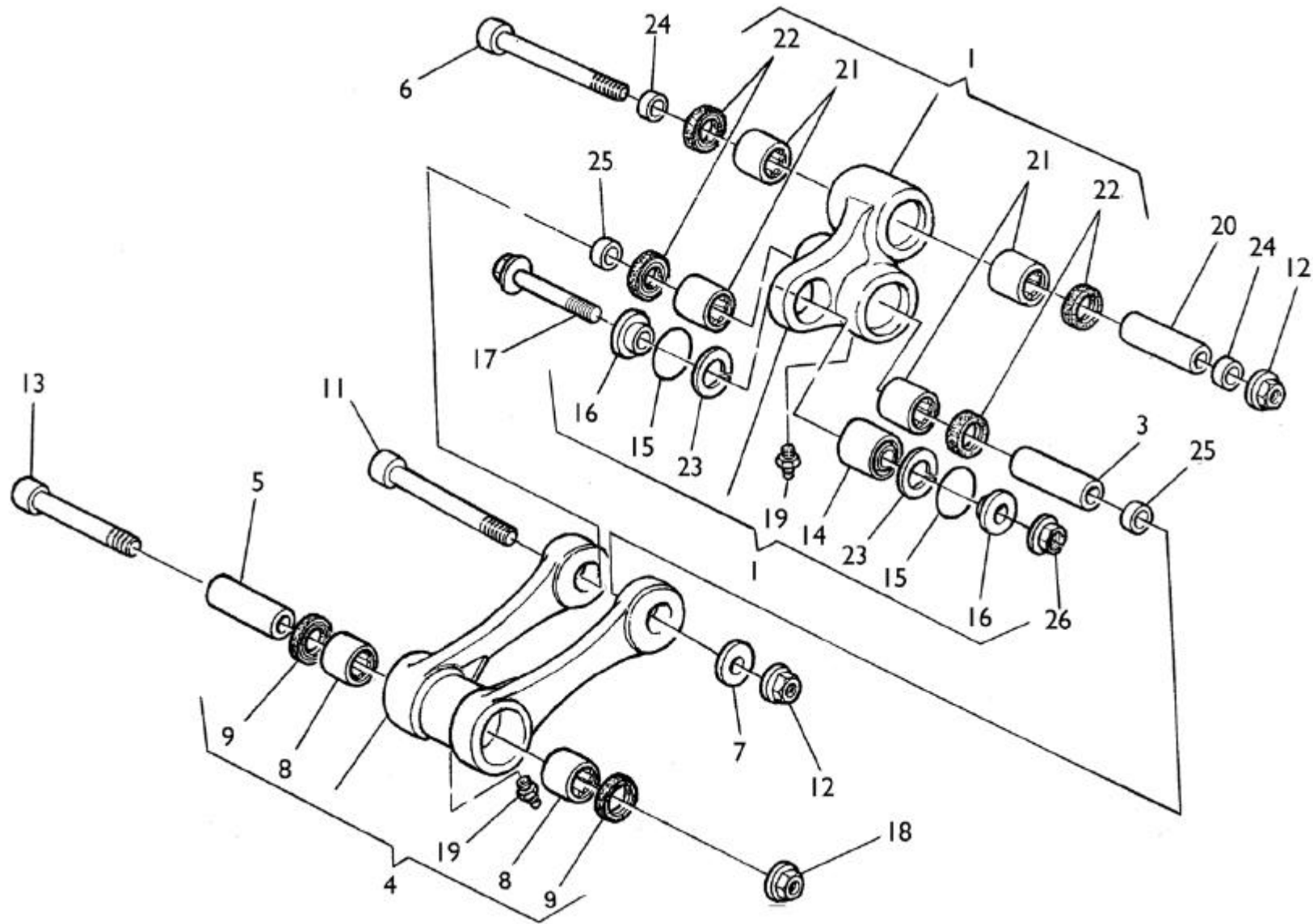

Note Notes Notas	Pos. No. Index Pos.	N. Cod. Code No. Nr. Code Code Nr N. Cod.	Q.tà Q.ty Q.te M.ge C.ad	DENOMINAZIONE	NAME	DESIGNATION	BESHREIBUNG	DENOMINACION	Validità Validity Validité Gültig Validez
	1	8000 97052	1	Assieme bilanciare	Rocking lever assy	Balancier compl.	Schwinge Kpl.	Balancines compl.	
	3	8000 86176	1	Spinotto	Gudgeon	Axe	Bolzen	Perno	
	4	8000 97054	1	Tirante completo	Tie rod	Tirant	Spannstange	Tirante	
	5	8000 97050	1	Spinotto	Gudgeon	Axe	Bolzen	Perno	
	6	8E00 86138	1	Vite (M12x100 mm)	Screw (M12x100 mm)	Vis (M12x100 mm)	Schraube (M12x100 mm)	Tornillo (M12x100 mm)	
	7	8000 86140	2	Rosetta	Washer	Rondelle	Scheibe	Arandela	
	8	8000 86136	2	Cuscinetto (ø22xø28x16 mm)	Bearing (ø22xø28x16 mm)	Roulement (ø22xø28x16 mm)	Lager (ø22xø28x16 mm)	Cojinete (ø22xø28x16 mm)	
	9	8000 38521	2	Anello di tenuta (ø22xø28x4 mm)	Seal ring (ø22xø28x4 mm)	Bague de retenue (ø22xø28x4 mm)	Dichtring (ø22xø28x4 mm)	Anillo de retención (ø22xø28x4 mm)	
	11	8000 93124	1	Vite (M12x103 mm)	Screw (M12x103 mm)	Vis (M12x103 mm)	Schraube (M12x103 mm)	Tornillo (M12x103 mm)	
	12	8000 42023	2	Dado	Nut	Ecrou	Mutter	Tuerca	
	13	8B00 86138	1	Vite (M12x121 mm)	Screw (M12x121 mm)	Vis (M12x121 mm)	Schraube (M12x121 mm)	Tornillo (M12x121 mm)	
	14	8000 72168	1	Cuscinetto sferico (ø12xø26x16 mm)	Bearing (ø12xø26x16 mm)	Roulement (ø12xø26x16 mm)	Lager (ø12xø26x16 mm)	Cojinete (ø12xø26x16 mm)	
	15	8000 38767	2	Anello OR	O-Ring	Bague OR	O-Ring	Anillo OR	
	16	1511 33302	2	Bussola	Bushing	Douille	Buchse	Manguito	
	17	8D00 62797	1	Vite (M10x47 mm)	Screw (M10x47 mm)	Vis (M10x47 mm)	Schraube (M10x47 mm)	Tornillo (M10x47 mm)	
	18	8000 42023	1	Dado	Nut	Ecrou	Mutter	Tuerca	
	19	8000 01412	2	Ingrassatore	Lubricator	Graisser	Schmierbüchse	Lubricador	
	20	8D00 86176	1	Spinotto	Gudgeon	Axe	Bolzen	Perno	
	21	8000 86136	4	Cuscinetto (ø22xø28x16 mm)	Bearing (ø22xø28x16 mm)	Roulement (ø22xø28x16 mm)	Lager (ø22xø28x16 mm)	Cojinete (ø22xø28x16 mm)	
	22	8000 86137	4	Anello di tenuta (ø26xø34x4 mm)	Seal ring (ø26xø34x4 mm)	Bague de retenue (ø26xø34x4 mm)	Dichtring (ø26xø34x4 mm)	Anillo de retención (ø26xø34x4 mm)	
	23	8000 90561	2	Anello elastico	Split ring	Anneau ressort	Sprengring	Anillo elástico	
	24	8A00 86177	2	Distanziale	Spacer	Entretoise	Distanzstück	Separadør	
	25	8000 86177	2	Distanziale	Spacer	Entretoise	Distanzstück	Separadør	
	26	8000 42022	1	Dado	Nut	Ecrou	Mutter	Tuerca	

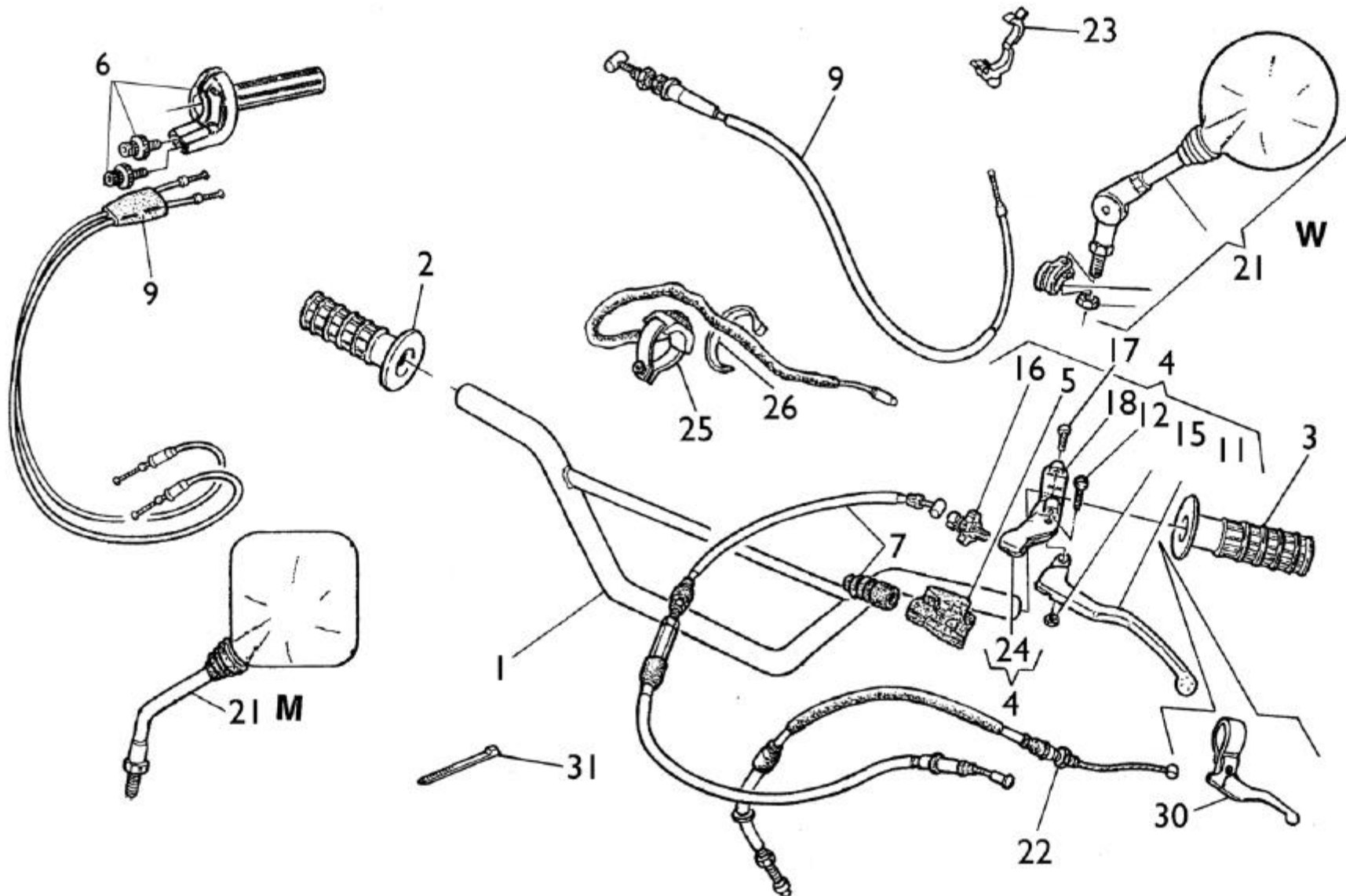

Note Notes Marka Notas	Pos. No. Index Pos.	N. Cod. Code No. Nr. Code Code Nr N. Cod.	Q.tà Q.ty Q.te M.ge C.ad	DENOMINAZIONE	NAME	DESIGNATION	BESHREIBUNG	DENOMINACION	Validità Validity Validité Gültig Validez
	1	8000 88280	1	Manubrio	Hanblebar	Guidon	Lenker	Manillar	
	2	8000 76688	1	Manopola Dx.	R.H. grip	Poignée G.	Griff R.	Manopla der.	
	3	8000 76687	1	Manopola Sx.	L.H. grip	Poignée G.	L. Griff	Manopla izrda.	
	4	8000 75330	1	Comando frizione compl.	Clutch control lever, assy	Levier com. embrayage compl.	Kupplungshebel, Kpl.	Palanca embrague comp.	
	5	8000 48917	1	Coprileva	Lever cover	Couvre levier	Hebeldeckel	Cubre-palanca mando embr.	
	6	8000 98209	1	Comando gas completo	Throttle control compl.	Commande gaz compl.	Gasgriff kpl.	Accionam. acelerador compl.	
	7	8000 96832	1	Trasmissione comando frizione	Clutch transm.	Transm. com. embrayage	Führungssteuer. der Kupplung	Tran. mando embr. compl.	
	9	8000 96833	1	Trasmissione comando gas	Throttle wire	Fil comm. gaz	Gaszugkabel	Trans. accionam. acelerador	
	11	8000 77737	1	Leva frizione	Clutch lever	Levier embrayage	Kupplungshebel	Palanca mando embrague	
	12	8000 38797	1	Vite	Screw	Vis	Schraube	Tornillo	
	15	8000 87812	1	Dado	Nut	Ecrou	Mutter	Tuerca	
	16	8000 48916	1	Gruppo registro	Adjuster set	Groupe reglage	Kupplungsreglergruppe	Grupo regul.	
	17	8000 62728	2	Vite	Screw	Vis	Schraube	Tornillo	
	18	8000 70698	1	Cavallotto	U-bolt	Cavalier	Bügelbolzen	Caballete	
MD	18	8000 78915	1	Cavallotto	U-bolt	Cavalier	Bügelbolzen	Caballete	
xwD	21	8000 65437	2	Specchietto retrov. Dx. e Sx.	Driving mirror	Rétrovisueur	Rückspiegel	Espejo retrovisor	
MD	21	8B00 68934	1	Specchietto retrov. Dx.	R.H. Driving mirror	Rétrovisueur D.	R. Rückspiegel	Espejo retrovisor der.	
MD	21	8C00 68934	1	Specchietto retrov. Sx.	L.H. Driving mirror	Rétrovisueur G.	L. Rückspiegel	Espejo retrovisor iz.	
	22	8A00 79754	1	Trasmissione decompressore	Decompression transm.	Trasm. décompression	Dekompressions Kabel	Transm. decompressore	
	23	8000 93101	1	Molletta	Clamp	Collier	Schelle	Banda	

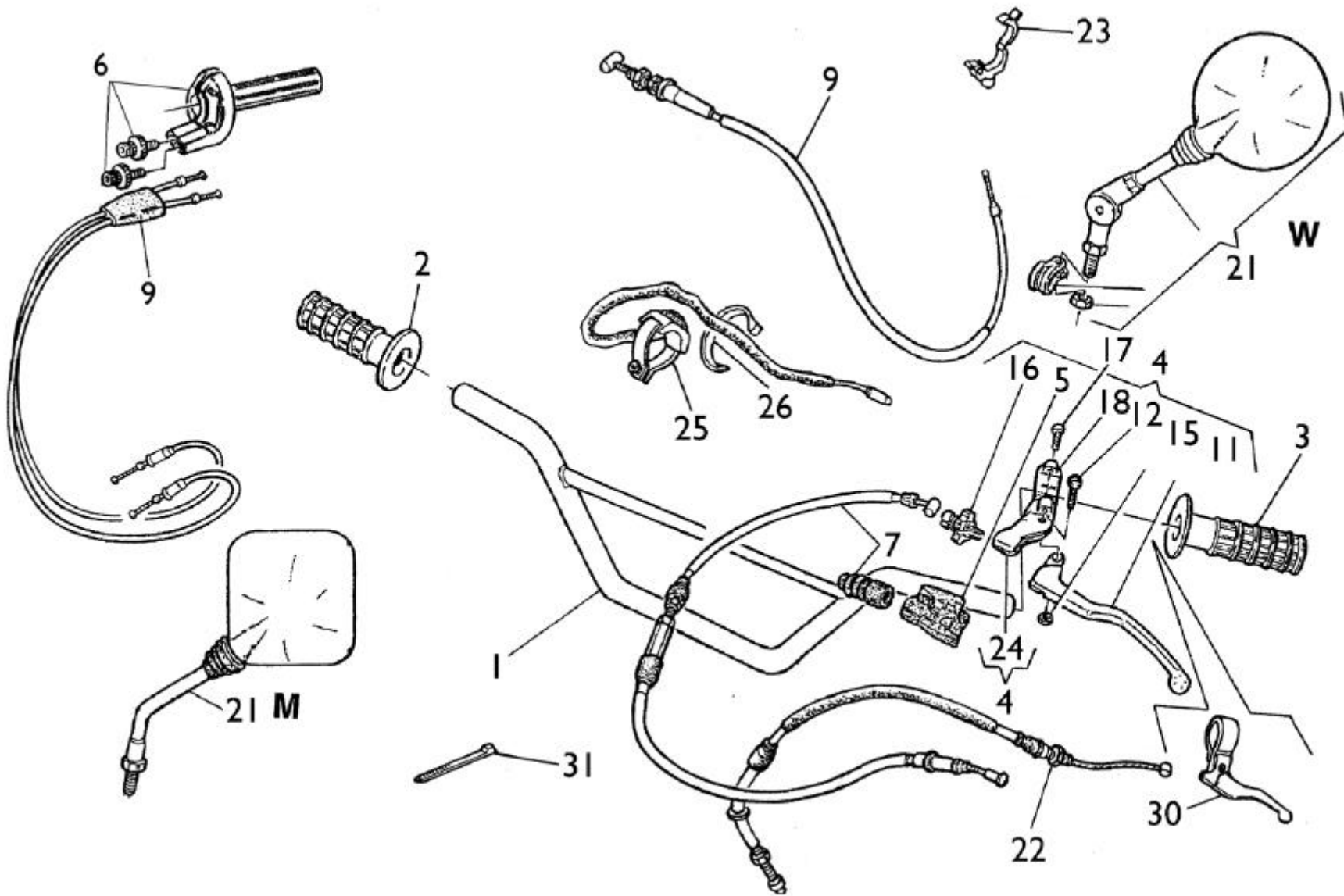

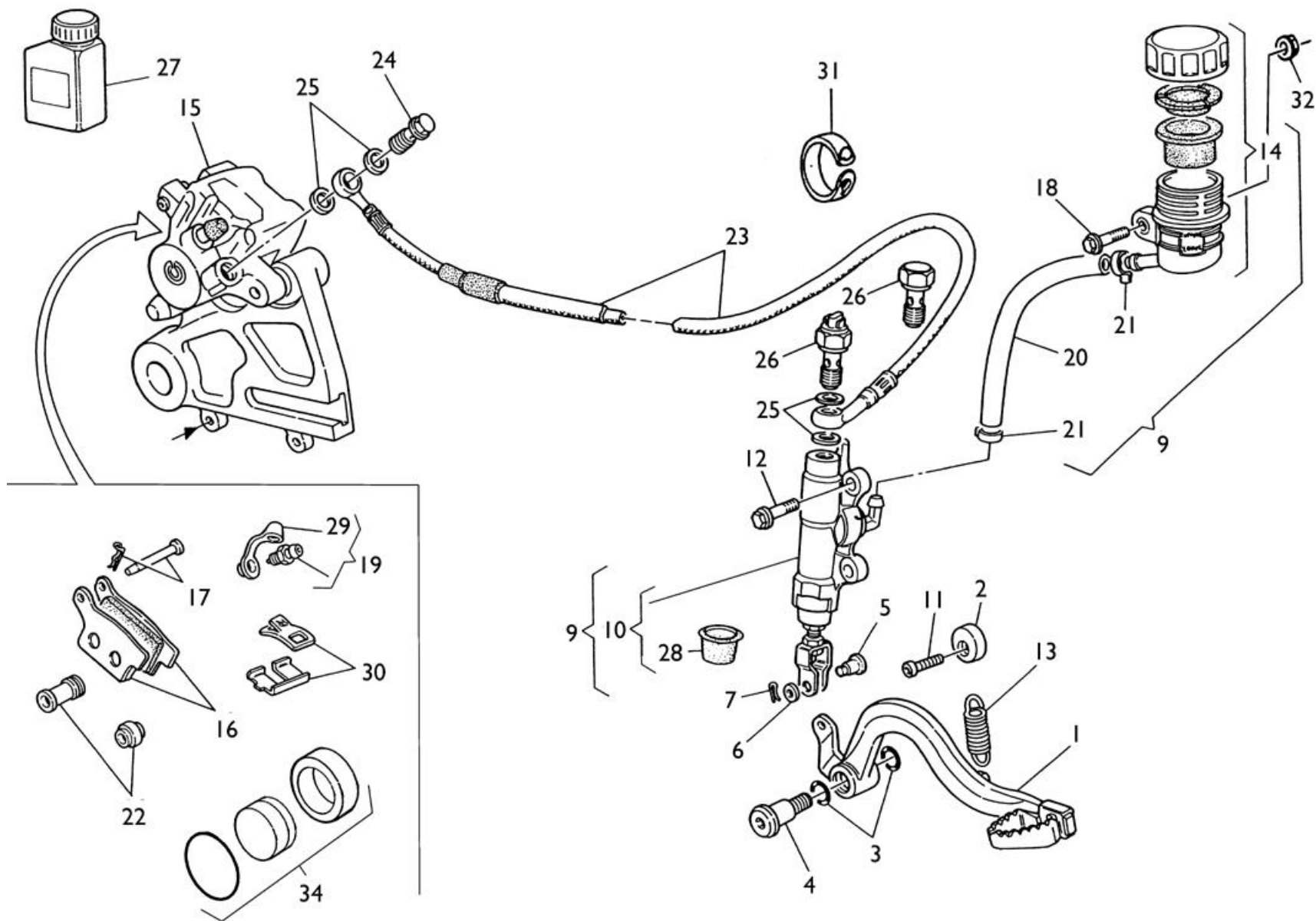

Note Notes Marka Notas	Pos. No. N. Index Pos.	N. Cod. Code No. Nr. Code Code Nr N. Cod.	Q.tà Q.ty Q.te M.ge C.ad	DENOMINAZIONE	NAME	DESIGNATION	BESHREIBUNG	DENOMINACION	Validità Validity Validité Gültig Validez
	1	8000 73343	1	Pedale comando freno	Brake control pedal	Pedal comm. frein	Bremspedal	Pedal accionamiento freno	
	2	8000 69125	1	Camma	Cam	Came	Nocken	Exéntrico	
	3	8000 22551	2	Anello OR	O-Ring	Bague OR	O-Ring	Anillo OR	
	4	8000 55902	1	Vite	Screw	Vis	Schraube	Tornillo	
	5	8000 70696	1	Perno	Pin	Pivot	Bolzen	Perno	
	6	8000 56377	1	Rosetta	Washer	Rondelle	Scheibe	Arandela	
	7	64NI 20068	1	Copiglia	Split pin	Goupille	Splint	Clavija	
	9	8C00 76026	1	Pompa comando freno compl.	Brake pump assy	Pompe frein complet	Bremspumpe kl.	Bomba freno compl.	
	10	8000 76338	1	Pompa freno	Brake pump	Pompe frein	Bremspumpe	Bomba freno	
	11	8A00 55241	1	Vite	Screw	Vis	Schraube	Tornillo	
	12	8000 62727	2	Vite	Screw	Vis	Schraube	Tornillo	
	13	8A00 55903	1	Molla	Spring	Ressort	Feder	Resorte	
	14	8000 61078	1	Serbatoio olio completo	Oil tank assy	Reservoir huile compl.	Öltank Kpl.	Depósito aceite completo	
	15	8000 99729	1	Pinza freno completa	Brake caliper assy	Pince de frein, compl.	Bremszange, Kpl.	Pinza freno compl.	
	16	8000 79072	1	Coppia pastiglie	Pads pair	Paire plaquettes	Bremsbelagpaar	Pareja pastillas	
R	16	8A00 79072	1	Coppia pastiglie sinterizzate	Pads pair sinterized	Paire plaquettes frittage	Bremsbelagpaar sistem	Pareja pastillas sinterizar	
	17	8000 A0936	1	Perno	Pin	Pivot	Bolzen	Perno	
	18	8000 62725	1	Vite	Screw	Vis	Schraube	Tornillo	
	19	8000 A0931	1	Spurgo	Spurgo	Drain	Entleerung	Purga	
	20	8S00 66179	1	Tubazione	Pipe	Tuyau	Rohr	Tubo	
	21	8000 42349	2	Molletta	Spring	Ressort	Feder	Resorte	
	22	8000 79066	1	Cuffie	Boots	Poussiers	haube	Gorro	
	23	8A00 78326	1	Tubo mandata olio	Pipe	Tuyau	Rohr	Tubo	
	24	8000 57155	1	Vite	Screw	Vis	Schraube	Tornillo	
	25	8000 21480	4	Rosetta	Washer	Rondelle	Scheibe	Arandela	
W	26	8000 94849	1	Interruttore stop posteriore	Rear stop switch	Interrupteur stop	Stopschalter	Interruptor stop	
U	26	8000 57155	1	Vite	Screw	Vis	Schraube	Tornillo	
R	27	8000 71445	1	Olio freni	Brake oil	Huile de frein	BremsÖl	Aceite freno	
	28	8000 79075	1	Cuffia	Boot	Poussier	haube	Gorro	
	29	8000 53259	1	Parapolvere	Boots	Para-poudre	Schutzhaube	Para-polvo	
	30	8000 85932	1	Molla-lamierino	Spring-steel clip	Ressort	Feder	Rresorte	

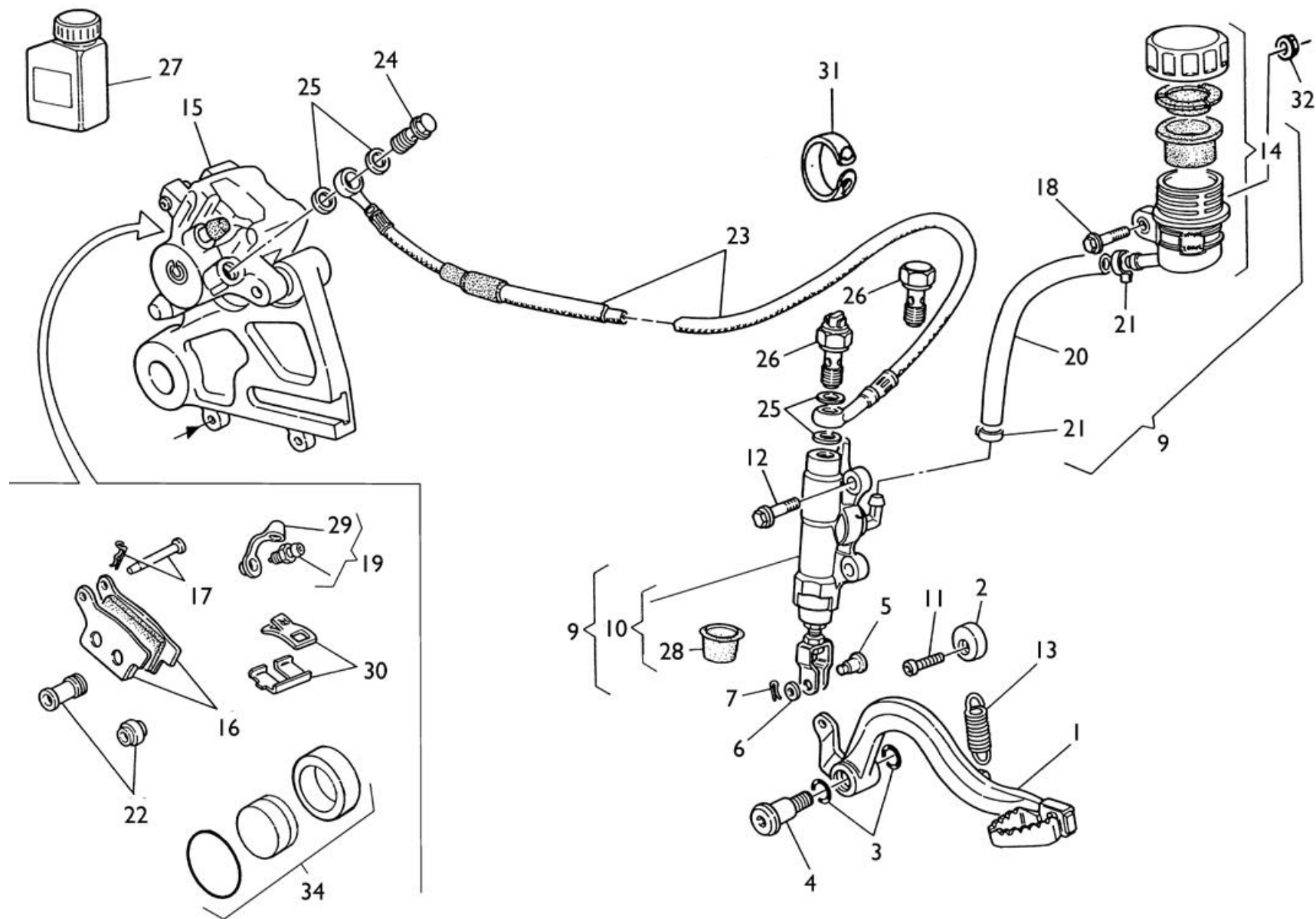



TE 570-
SM 570 R/ 2003

TAVOLA
DRAWING
TABLE
BILD
TABLA

18

FRENO IDRAULICO POSTERIORE - REAR HYDRAULIC BRAKE
FREIN HYDRAULIQUE ARRIERE - HINTERBREMSE
FRENO HIDRAULICO TRASERO

Note Notes Marke Notas	Pos. No. N. Index Pos.	N. Cod. Code No. Nr. Code Code Nr N. Cod.	Q.tà Q.ty Q.te M.ge C.ad	DENOMINAZIONE	NAME	DESIGNATION	BESHREIBUNG	DENOMINACION	Validità Validity Validité Gültig Validez
	31	8000 53724	2	Fascetta	Guard	Protection	Schut	Protecion	
	32	8000 44240	1	Dado	Bushing	Douille	Buchse	Manguito	
	34	8000 A0935	1	Pistone	Piston	Piston	Kolben	Pistón	

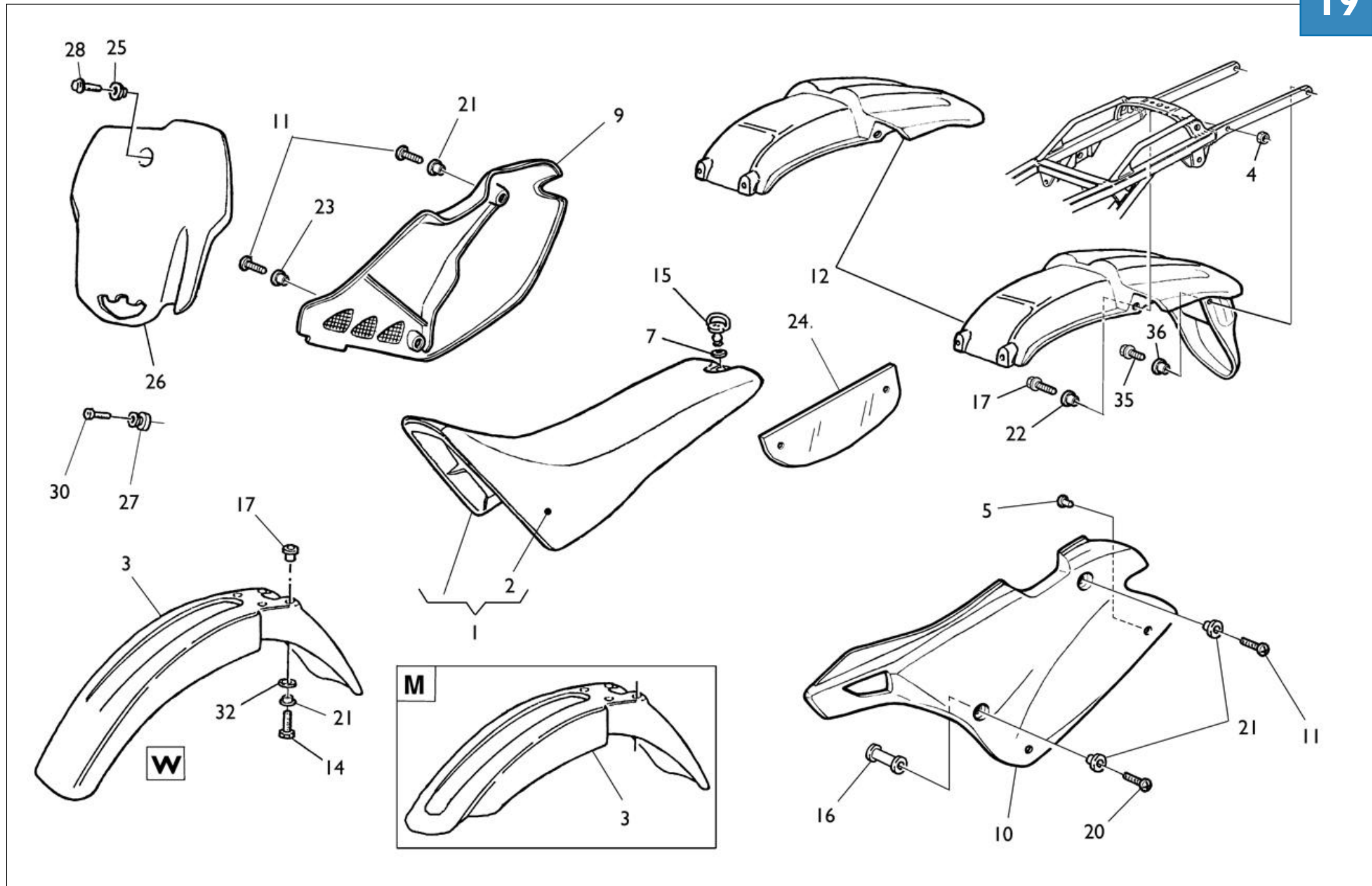

Note Notes Marka Notas	Pos. No. N. Index Pos.	N. Cod. Code No. Nr. Code Code Nr N. Cod.	Q.tà Q.ty Q.te M.ge C.ad	DENOMINAZIONE	NAME	DESIGNATION	BESHREIBUNG	DENOMINACION	Validità Validity Validité Gültig Validez
W	1	8000 A0193	1	Sella	Seat	Siège	Sattel	Sillín	
M	1	8B00 A0193	1	Sella (codice colore E)	Seat (color code E)	Siège (code couleur E)	Sattel (Code Farbe E)	Sillín (còdigo colòr E)	
M	1	8A00 A0193	1	Sella (codice colore G)	Seat (color code G)	Siège (code couleur G)	Sattel (Code Farbe G)	Sillín (còdigo colòr G)	
W	2	8000 A0192	1	Rivestimento sella	Saddle covering	Revetement selle	Sattelverkleidung	Revestimiento sillín	
M	2	8000 A0192	1	Rivestimento sella (codice colore E)	Saddle covering (color code E)	Revetement selle (code couleur E)	Sattelverkleidung (Code Farbe E)	Revestimiento sillín (còdigo colòr E)	
M	2	8A00 A0192	1	Rivestimento sella (codice colore G)	Saddle covering (color code G)	Revetement selle (code couleur G)	Sattelverkleidung (Code Farbe G)	Revestimiento sillín (còdigo colòr G)	
W	3	8000 A1589	1	Parafango anteriore	Front mudguard	Garde-boue avant	Vord. Kotfluegel	Guarda-barros delantero	
M	3	8000 A1761	1	Parafango anteriore (tipo corto) (codice colore E)	Front mudguard (short type) (color code E)	Garde-boue avant (type court) (code couleur E)	Vord. Kotfluegel (short type) (Code Farbe E)	Guarda-barros delantero (tipo corto) (còdigo colòr E)	
M	3	80A0 A1761	1	Parafango anteriore (tipo corto) (codice colore G)	Front mudguard (short type) (color code G)	Garde-boue avant (type court) (code couleur G)	Vord. Kotfluegel (short type) (Code Farbe G)	Guarda-barros delantero (tipo corto) (còdigo colòr G)	
	4	8000 61313	2	Dado	Nut	Ecrou	Mutter	Tuerca	
	5	8000 45490	2	Gommino	Rubber pad	Pièce caoutchouc	Gummstück	Junta de goma	
	7	8000 69149	1	Rosetta elastica	Spring washer	Rondelle élastique	Federscheibe	Arandela elástica	
W	9	80B0 92958	1	Pannello destro	R.H. panel	Panneau, D.	Streifen, R.	Panel der.	
M	9	80B0 92958	1	Pannello destro (codice colore E)	R.H. panel (color code E)	Panneau, D. (code couleur E)	Streifen, R. (Code Farbe E)	Panel der. (còdigo colòr E)	
M	9	80A0 92958	1	Pannello destro (codice colore G)	R.H. panel (color code G)	Panneau, D. (code couleur G)	Streifen, R. (Code Farbe G)	Panel der. (còdigo colòr G)	
W	10	80B0 92959	1	Pannello sinistro	L.H. panel	Panneau, G.	Streifen, L.	Panel izq.	
M	10	80B0 92959	1	Pannello sinistro (codice colore E)	L.H. panel (color code E)	Panneau, G. (code couleur E)	Streifen, L. (Code Farbe E)	Panel izq. (còdigo colòr E)	
M	10	80A0 92959	1	Pannello sinistro (codice colore G)	L.H. panel (color code G)	Panneau, G. (code couleur G)	Streifen, L. (Code Farbe G)	Panel izq. (còdigo colòr G)	

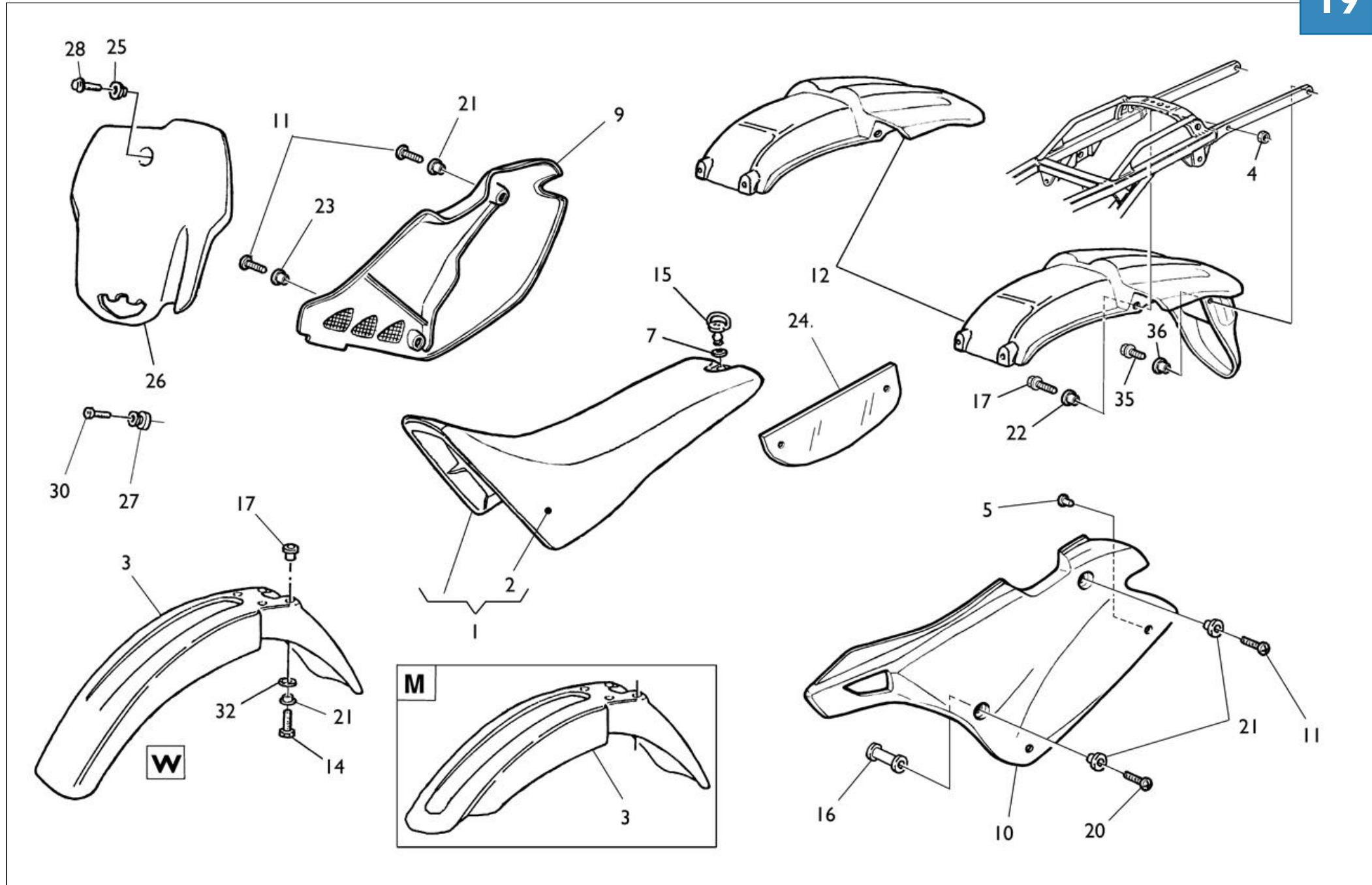

Note Notes Marka Notas	Pos. No. N. Index Pos.	N. Cod. Code No. Nr. Code Code Nr N. Cod.	Q.tà Q.ty Q.te M.ge C.ad	DENOMINAZIONE	NAME	DESIGNATION	BESCHREIBUNG	DENOMINACION	Validità Validity Validité Gültig Validez
	11	8000 62728	2	Vite anteriore (M6x20 mm)	Front screw (M6x20 mm)	Vis avant (M6x20 mm)	Vord. Schraube (M6x20 mm)	Tornillo del. (M6x20 mm)	
	11	8000 62727	2	Vite posteriore (M6x16 mm)	Rear screw (M6x16 mm)	Vis arriere (M6x16 mm)	Hint. Schraube (M6x16 mm)	Tornillo tras. (M6x16 mm)	
EW	12	8AA0 88856	1	Parafango posteriore	Rear mudguard	Garde-boue arriere	Hint.Kotfluegel	Guarda-barros trasero	
W	12	8A00 A0545	1	Parafango posteriore	Rear mudguard	Garde-boue arriere	Hint.Kotfluegel	Guarda-barros trasero	
				(codice colore E)	(color code E)	(code couleur E)	(Code Farbe E)	(còdigo colòr E)	
W	12	8BA0 A0545	1	Parafango posteriore	Rear mudguard	Garde-boue arriere	Hint.Kotfluegel	Guarda-barros trasero	
				(codice colore G)	(color code G)	(code couleur G)	(Code Farbe G)	(còdigo colòr G)	
U	12	8A00 A0546	1	Parafango posteriore	Rear mudguard	Garde-boue arriere	Hint.Kotfluegel	Guarda-barros trasero	
M	12	8BA0 A0545	1	Parafango posteriore	Rear mudguard	Garde-boue arriere	Hint.Kotfluegel	Guarda-barros trasero	
	14	8000 62727	4	Vite (M6x16 mm)	Screw (M6x16 mm)	Vis (M6x16 mm)	Schraube (M6x16 mm)	Tornillo (M6x16 mm)	
	15	8000 69148	1	Perno	Pin	Pivot	Bolzen	Perno	
	16	1519 76702	1	Distanziale	Spacer	Entretoise	Distanzstück	Separador	
	17	8000 62728	2	Vite (M6x20 mm)	Screw (M6x20 mm)	Vis (M6x20 mm)	Schraube (M6x20 mm)	Tornillo (M6x20 mm)	
	20	8D00 67545	1	Vite (M6x60 mm)	Screw (M6x60 mm)	Vis (M6x60 mm)	Schraube (M6x60 mm)	Tornillo (M6x60 mm)	
	21	8000 69429	5	Bussola	Bushing	Douille	Buchse	Manguito	
	22	8000 69429	2	Bussola	Bushing	Douille	Buchse	Manguito	
	23	8A00 69429	1	Bussola	Bushing	Douille	Buchse	Manguito	
	24	8000 94267	1	Protezione	Guard	Protection	Schutz	Protección	
U	25	8B00 69282	1	Bussola	Bushing	Douille	Buchse	Manguito	
U	26	80B0 87800	1	Portanumero	Number holder	Porte numero	Nummerträger	Porta numero	
M	26	80A0 87800	1	Portanumero (USA)	Number holder (USA)	Porte numero (USA)	Nummerträger (USA)	Porta numero (USA)	
U	27	8000 A0241	2	Attacco portanumero	Spacer	Entretoise	Distanzstück	Separador	
U	28	8C00 67997	1	Vite	Screw	Vis	Schraube	Tornillo	
U	30	8000 62726	2	Vite	Screw	Vis	Schraube	Tornillo	
	32	8000 48814	4	Rosetta	Washer	Rondelle	Scheibe	Arandela	
	35	8000 62726	2	Vite (M6x14 mm)	Screw (M6x14 mm)	Vis (M6x14 mm)	Schraube (M6x14 mm)	Tornillo (M6x14 mm)	
	36	8000 45495	2	Bussola	Bushing	Douille	Buchse	Manguito	

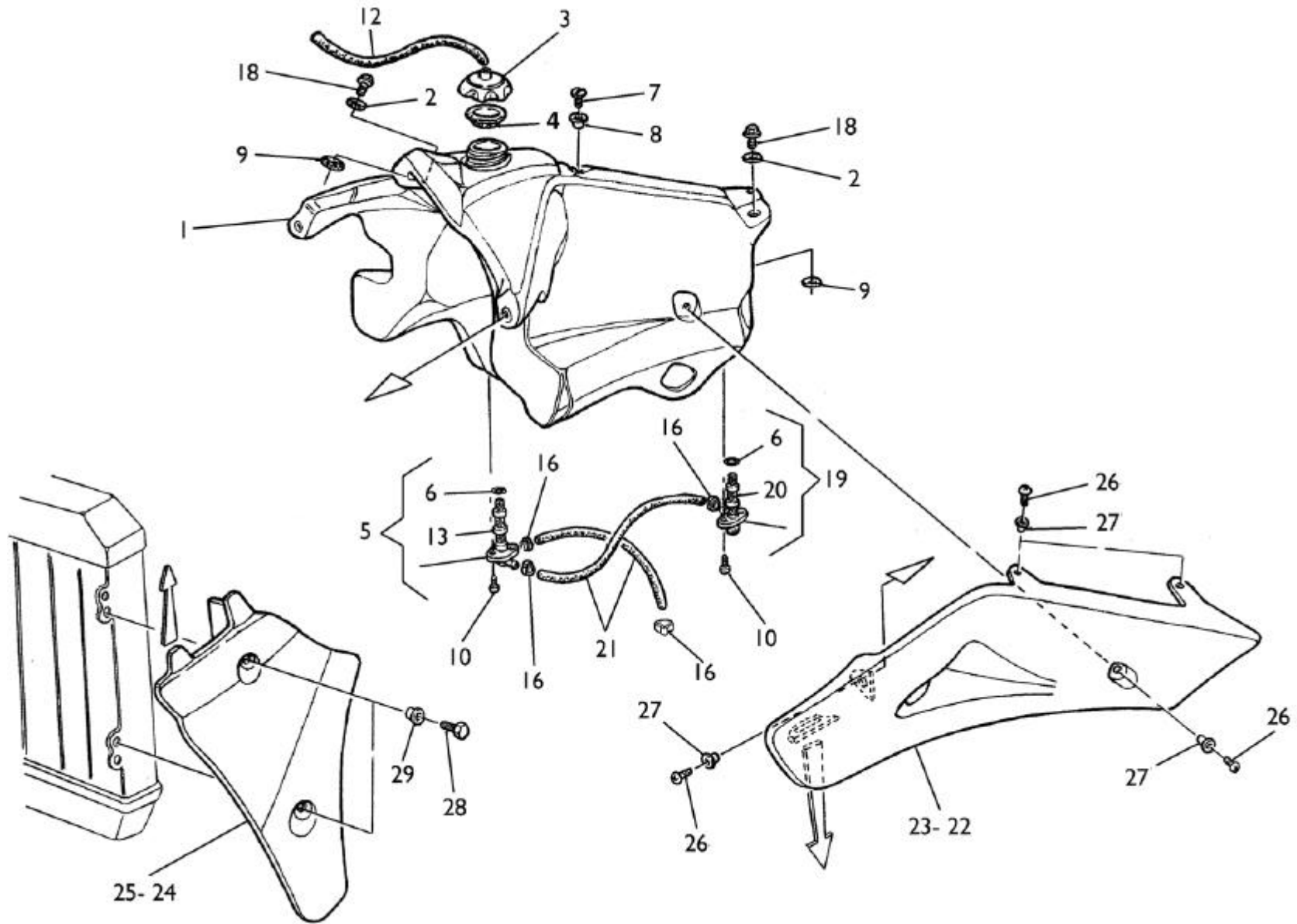

Note Notes Marka Notas	Pos. No. N. Index Pos.	N. Cod. Code No. Nr. Code Code Nr N. Cod.	Q.tà Q.ty Q.te M.ge C.ad	DENOMINAZIONE	NAME	DESIGNATION	BESHREIBUNG	DENOMINACION	Validità Validity Validité Gültig Validez
	1	8A00 96819	1	Serbatoio carburante (l 9)	Fuel tank (l 9)	Réservoir essence (l 9)	Kraftstoffbehälter (l 9)	Depósito gasolina (l 9)	
	2	8000 30319	3	Rosetta piana	Washer	Rondelle	Scheibe	Arandela	
	3	8000 94098	1	Tappo	Plug	Bouchon	Verschluss	Tapón	
	4	8000 56381	1	Guarnizione	Gasket	Garniture	Dichtung	Junta	
	5	8000 66648	1	Rubinetto Dx.	R.H. cock	Robinet D.	R.Kraftstoffahn	Llave de paso der.	
	6	8000 01199	2	Anello OR	O-Ring	Bague OR	O-Ring	Anillo OR	
	7	60NI 04134	1	Vite	Screw	Vis	Schraube	Tornillo	
	8	8000 66238	1	Distanziale	Spacer	Entretoise	Distanzstück	Separador	
	9	8000 61362	3	Tampone	Pad	Tampon	Stopfen	Tampón	
	10	8000 37745	4	Vite	Screw	Vis	Schraube	Tornillo	
	12	8S00 68873	1	Tubetto sfianto	Battery breather pipe	Event batterie	Batterieentlüfter	Tubo de purga batería	
	13	8000 38748	1	Filtro benzina	Fuel filter	Filtre essence	Benzinfilter	Filtro gasolina	
	16	80A0 42349	4	Fascetta	Clamp	Collier	Schelle	Banda	
	18	8000 62726	3	Vite	Screw	Vis	Schraube	Tornillo	
	19	8000 67440	1	Rubinetto Sx.	L.H. cock	Robinet G.	L.Kraftstoffahn	Llave de paso izq.	
	20	8000 67700	1	Filtro benzina	Fuel filter	Filtre essence	Benzinfilter	Filtro gasolina	
	21	8A00 94010	1	Condotto benzina (L=210 mm)	Pipe (L=210 mm)	Tuyau (L=210 mm)	Rohr (L=210 mm)	Tubo (L=210 mm)	
	21	8C00 94010	1	Condotto benzina (L=260 mm)	Pipe (L=260 mm)	Tuyau (L=260 mm)	Rohr (L=260 mm)	Tubo (L=260 mm)	
W	22	8000 96816	1	Convogliatore DX	R. side panel	Flanc D.	Flanke R.	Lateral D.	
M	22	8000 96816	1	Conv. DX (codice colore E)	R. side panel (color code E)	Flanc D. (code couleur E)	Flanke R. (Code Farbe E)	Lateral D. (código colòr E)	
M	22	8AA0 96816	1	Conv. DX (codice colore G)	R. side panel (color code G)	Flanc D. (code couleur G)	Flanke R. (Code Farbe G)	Lateral D. (código colòr G)	
W	23	8000 96815	1	Convogliatore SX	L. side panel	Flanc G.	Flanke L.	Lateral I.	
M	23	8000 96815	1	Conv. SX (codice colore E)	L. side panel (color code E)	Flanc G. (code couleur E)	Flanke L. (Code Farbe E)	Lateral I. (código colòr E)	
M	23	8AA0 96815	1	Conv. SX (codice colore G)	L. side panel (color code G)	Flanc G. (code couleur G)	Flanke L. (Code Farbe G)	Lateral I. (código colòr G)	
	24	8000 96818	1	Protezione Dx	R.H. protection	Protection D.	Schutz Rechte	Protección derecha	
	25	8000 96817	1	Protezione Sx	L.H. protection	Protection G.	Schutz Linke	Protección izquierda	
	26	8000 36467	8	Vite (M6x10 mm)	Screw (M6x10 mm)	Vis (M6x10 mm)	Schraube (M6x10 mm)	Tornillo (M6x10 mm)	
	27	8000 45495	8	Bussola	Bushing	Douille	Buchse	Manguito	
	28	8000 62727	4	Vite (M6x16 mm)	Screw (M6x16 mm)	Vis (M6x16 mm)	Schraube (M6x16 mm)	Tornillo (M6x16 mm)	
	29	8000 69429	4	Bussola	Bushing	Douille	Buchse	Manguito	

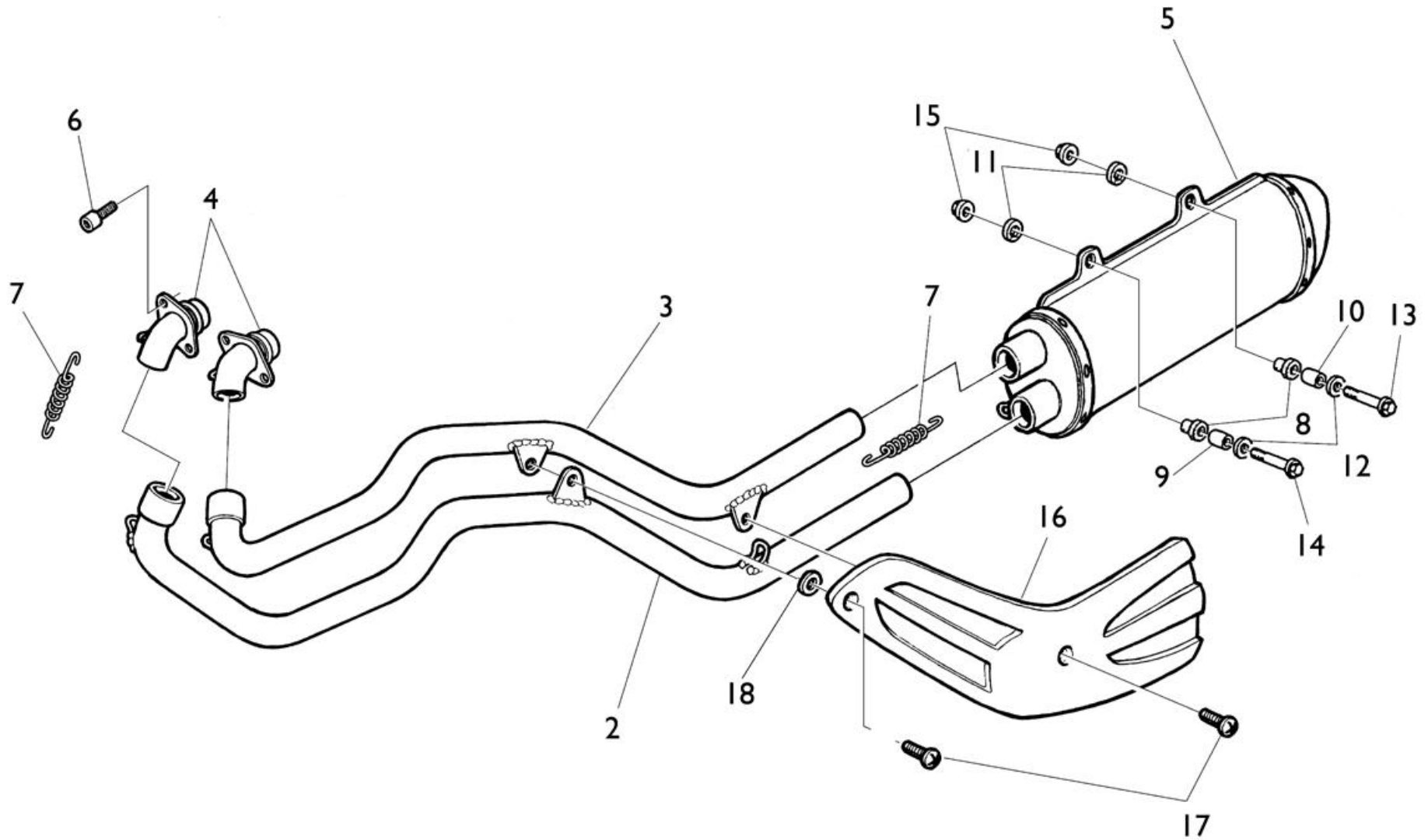

Note Notes Marka Notas	Pos. No. Index Pos.	N. Cod. Code No. Nr. Code Code Nr N. Cod.	Q.tà Q.ty M.ge C.ad	DENOMINAZIONE	NAME	DESIGNATION	BESHREIBUNG	DENOMINACION	Validità Validity Validité Gültig Validez
	2	8000 93052	1	Tubo di scarico Dx	R.H. exhaust pipe	Tuyau d'échapp. D..	Auspuffrohr R..	Tubo de escape der	
	3	8000 93051	1	Tubo di scarico Sx	L.H. exhaust pipe.	Tuyau d'échapp. G..	Auspuffrohr L..	Tubo de escape izq.	
	4	8000 93916	2	Raccordo tubi scarico	Union exhaust pipe	Raccord tuyau d'échapp.	Anschluss Auspuffrohr	Empalme tubo de escape	
WM	5	8000 93049	1	Silenziatore	Exhaust silencer	Silencieux d'échappement	Schalldämpfer	Silenciador de escape	
U	5	8000 93100	1	Silenziatore	Exhaust silencer	Silencieux d'échappement	Schalldämpfer	Silenciador de escape	
	6	60N4 07335	4	Vite	Screw	Vis	Schraube	Tornillo	
	7	8000 67496	3	Molla	Spring	Ressort	Feder	Resorte	
	8	1514 10702	2	Distanziale in gomma	Rubber spacer	Entretoise en caoutchouc	Gummi Distanzstück	Separador de goma	
W	9	8000 70379	1	Distanziale	Spacer	Entretoise	Distanzstück	Separador	
M	9	8B00 70379	1	Distanziale	Spacer	Entretoise	Distanzstück	Separador	
W	10	8A00 70379	1	Distanziale	Spacer	Entretoise	Distanzstück	Separador	
M	10	8D00 70379	1	Distanziale	Spacer	Entretoise	Distanzstück	Separador	
	11	1513 41401	2	Rosetta in gomma	Rubber washer	Rondelle en caoutchouc	Gummischeibe	Arandela de goma	
	12	1513 74301	2	Rosetta	Washer	Rondelle	Scheibe	Arandela	
W	13	8E00 67545	1	Vite (M6x40 mm)	Screw (M6x40 mm)	Vis (M6x40 mm)	Schraube (M6x40 mm)	Tornillo (M6x40 mm)	
M	13	8000 62731	1	Vite (M6x45 mm)	Screw (M6x45 mm)	Vis (M6x45 mm)	Schraube (M6x45 mm)	Tornillo (M6x45 mm)	
W	14	8A00 67545	1	Vite (M6x35 mm)	Screw (M6x35 mm)	Vis (M6x35 mm)	Schraube (M6x35 mm)	Tornillo (M6x35 mm)	
M	14	8E00 67545	1	Vite (M6x40 mm)	Screw (M6x40 mm)	Vis (M6x40 mm)	Schraube (M6x40 mm)	Tornillo (M6x40 mm)	
	15	8000 44240	2	Dado	Nut	Ecrou	Mutter	Tuerca	
	16	8000 93917	1	Griglia	Grille	Grille	Gitter	Rejilla	
	17	8000 60898	2	Vite	Screw	Vis	Schraube	Tornillo	
	18	8000 60969	1	Rosetta	Washer	Rondelle	Scheibe	Arandela	

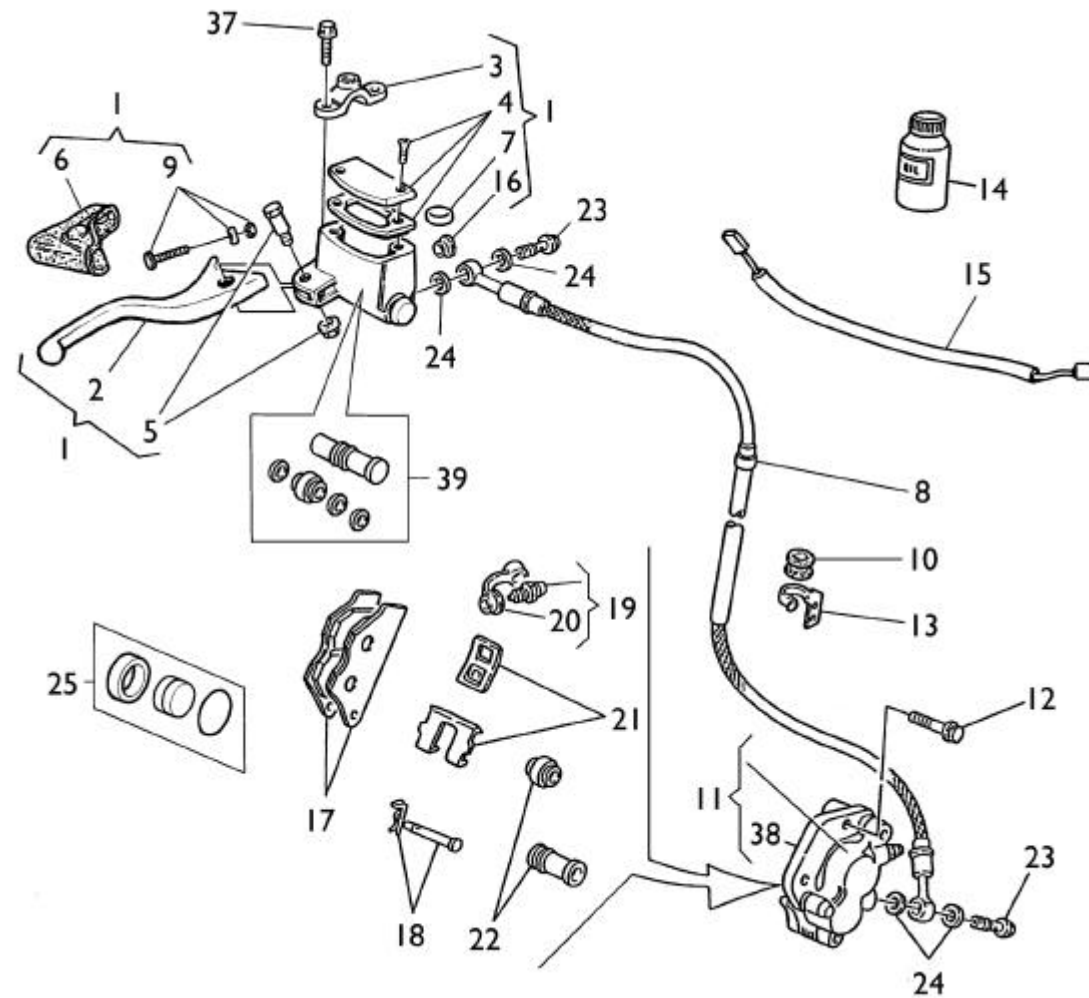

Note Notes Marka Notas	Pos. No. N. Index Pos.	N. Cod. Code No. Nr. Code Code Nr N. Cod.	Q.tà Q.ty Q.te M.ge C.ad	DENOMINAZIONE	NAME	DESIGNATION	BESHREIBUNG	DENOMINACION	Validità Validity Validité Gültig Validez
W	1	8000 99715	1	Pompa comando freno ant.	Brake pump	Pompe frein	Bremspumpe	Bomba freno	
U	1	8000 96831	1	Pompa comando freno ant.	Brake pump	Pompe frein	Bremspumpe	Bomba freno	
	2	8000 96830	1	Leva	Lever	Levier	Hebel	Palanca	
	3	8000 94125	1	Cavallotto	U-bolt	Cavalier	Bügelbolzen	Caballete	
	4	8000 94126	1	Kit tappo	Plug kit	Bouchon kit	Verschluss Gruppe	Kit tapón	
	5	8000 94127	1	Perno	Pin	Pivot	Bolzen	Perno	
	6	8000 94128	1	Cappuccio	Cap	Capuchon	Kappe	Capuchon	
	7	8000 79099	1	Antiemulsione	Antiemulsion	Antiemulsion	Eulsionwidriger	Antiemulsion	
W	8	8000 A0600	1	Tube mandata olio	Pipe	Tuyau	Rohr	Tube	
W	9	8000 94129	1	Regolazione	Adjuster	Registre	Regler	Regulizador	
	10	8000 71806	1	Occhiello passatubo	Fairlead	Passe câble	Kabelführung	Prensa cable	
W	11	8000 99674	1	Pinza freno	Brake caliper	Etrier frein	Bremssattel	Pinza	
	12	8000 62733	2	Vite	Screw	Vis	Schraube	Tornillo	
W	13	8000 90104	1	Piastrina di ritegno	Plate	Plaque	Platte	Placa	
U	13	8000 72022	1	Piastrina di ritegno	Plate	Plaque	Platte	Placa	
R	14	8000 71445	1	Olio freni	Brake oil	Huile frein	Bremsol	Aceite freni	
XW	15	8000 A0929	1	Interruttore stop	Stop switch	Interrupteur stop	Stopschalter	Interruptor stop	
	16	8000 49654	1	Oblò	Inspection plug	Capuchon de inspection	Stopfen	Portilla	
	17	8000 96934	1	Coppia pastiglie	Pads pair	Paire plaquettes	Bremsbelagpaar	Pareja pastillas	
W	18	8000 A0932	1	Perno	Pin	Pivot	Bolzen	Perno	
W	19	8000 A0931	1	Spurgo	Spurgo	Drain	Entleerung	Purga	
	20	8000 53259	1	Parapolvere	Boots	Para-poudre	Schutzhaube	Para-polvo	
	21	8000 79065	1	Molla-lamierino	Spring-steel clip	Ressort	Feder	Rresorte	
	22	8000 79066	1	Cuffie	Boots	Poussiers	haube	Gorro	
	23	8000 57155	2	Vite	Screw	Vis	Schraube	Tornillo	
	24	8000 21480	4	Rosetta	Washer	Rondell'e	Scheibe	Arandela	
	25	8000 A0930	1	Pistone	Piston	Piston	Kolben	Pistón	

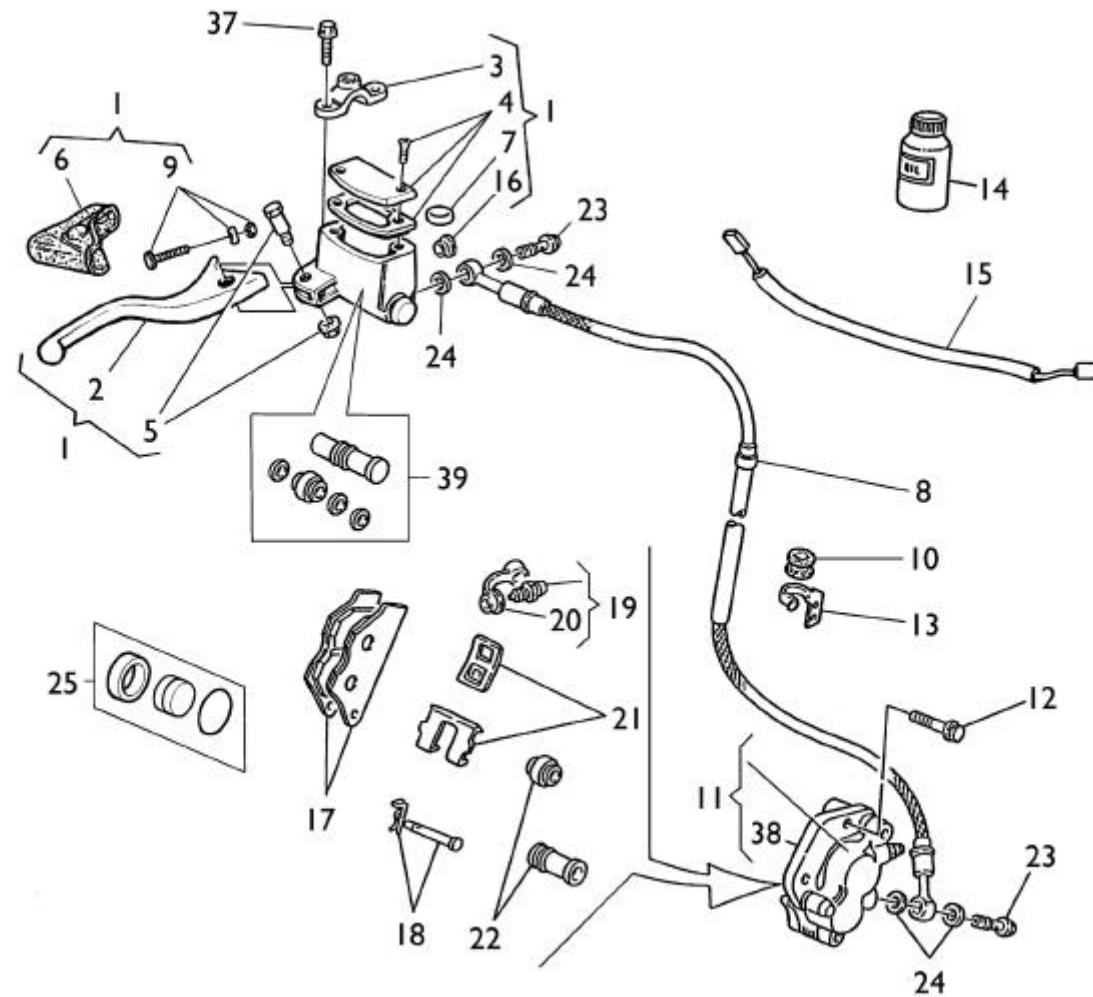

Note Notes Notas	Pos. No. Index Pos.	N. Cod. Code No. Nr. Code Code Nr N. Cod.	Q.tà Q.ty Q.te M.ge C.ad	DENOMINAZIONE	NAME	DESIGNATION	BESHREIBUNG	DENOMINACION	Validità Validity Validité Gültig Validez
	37	8000 62729	2	Vite	Screw	Vis	Schraube	Tornillo	
	38	8000 99859	1	Supporto	Holder	Support	Halterung	Soporte	
W	39	8000 A0928	1	Flottante	Pin	Pivot	Bolzen	Perno	
U	39	8000 A1137	1	Flottante	Pin	Pivot	Bolzen	Perno	

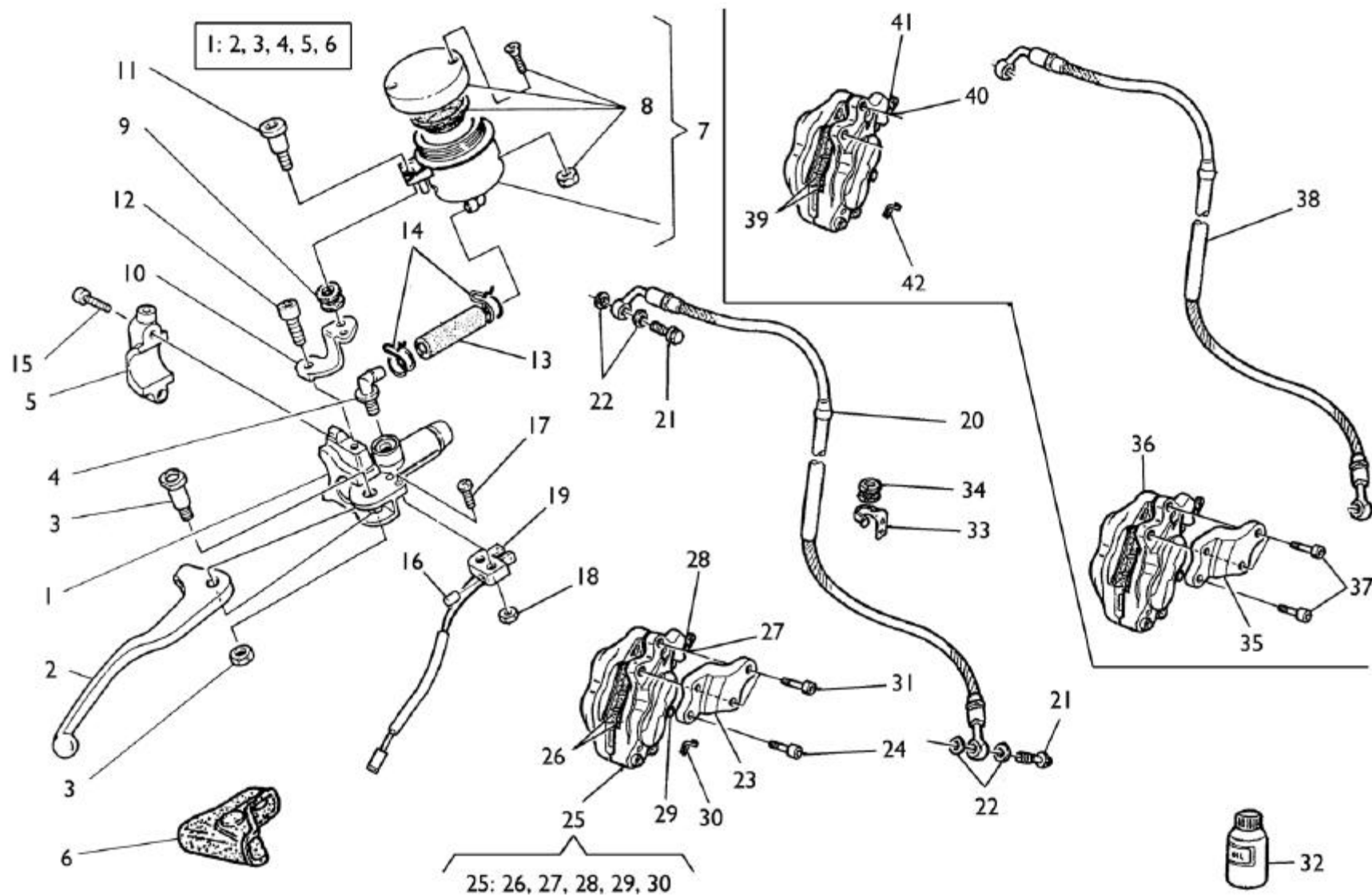

Note Notes Marka Notas	Pos. No. N. Index Pos.	N. Cod. Code No. Nr. Code Code Nr N. Cod.	Q.tà Q.ty Q.te M.ge C.ad	DENOMINAZIONE	NAME	DESIGNATION	BESHREIBUNG	DENOMINACION	Validità Validity Validité Gültig Validez
	1	8000 A0694	1	Pompa comando freno ant.	Brake pump	Pompe frein	Bremspumpe	Bomba freno	
	2	80A0 52662	1	Leva	Lever	Levier	Hebel	Palanca	
	3	8000 46664	1	Gruppo revisione perno leva	Pin lever	Goujon levier	Bolzen Hebel	Perno palanca	
	4	8000 42345	1	Gruppo revisione raccordo	Connection set	Kit revision raccord	Anschluss repar. Stz	Grupo revis. empalme	
	5	8000 A0879	1	Cavallotto	U-bolt	Cavalier	Bügelbolzen	Caballette	
	6	8000 A0811	1	Cappuccio	Cap	Capuchon	Kappe	Capuchon	
	7	8000 66181	1	Serbatoio olio	Oil tank	Reservoir huile	Öltank	Depósito aceite	
	8	8000 68490	1	Gruppo revisione tappo	Plug set	Kit revision capuchon	Stopfensatz	Grupo revis. tapón	
	9	8000 33288	1	Antivibrante	Rubber pad	Pièce caoutchouc	Gummistück	Junta de goma	
	10	8A00 62714	1	Piastrina	Plate	Plaquette	Plättchen	Placa	
	11	8000 A1189	1	Vite	Screw	Vis	Schraube	Tornillo	
	12	8000 62725	1	Vite	Screw	Vis	Schraube	Tornillo	
	13	8G00 66179	1	Tubazione	Pipe	Tuyau	Rohr	Tubo	
	14	8000 18921	2	Anello SEEGER	SEEGER ring	Anneau SEEGER	Ring SEEGER	Anillo SEEGER	
	15	8000 62729	2	Vite (M6x25mm)	Screw (M6x25mm)	Vis (M6x25mm)	Schraube (M6x25mm)	Tornillo (M6x25mm)	
X	16	8000 55772	1	Nottolino	Pawl	Cliquet	Klinke	Pestillo	
X	17	60NI 07701	2	Vite	Screw	Vis	Schraube	Tornillo	
X	18	6INI 15501	2	Dado	Nut	Ecrou	Mutter	Tuerca	
X	19	8000 A0672	1	Interruttore stop	Stop switch	Interrupteur stop	Stopschalter	Interruptor stop	
E	20	8000 A0393	1	Tubo mandata olio	Pipe	Tuyau	Rohr	Tubo	
	21	8000 57155	2	Bocchettone	Pipe union	Goulotte	Stutzen	Boca	
	22	8000 21480	4	Rosetta di tenuta	Washer	Rondelle	Scheibe	Arandela	
E	23	8A00 95599	1	Piastra	Plate	Plaque	Platte	Placa	
	24	8A00 94060	2	Vite (M10x35mm)	Screw (M10x35mm)	Vis (M10x35mm)	Schraube (M10x35mm)	Tornillo (M10x35mmmm)	
E	25	8000 93216	1	Pinza freno	Brake caliper	Etrier frein	Bremssattel	Pinza	
E	26	8000 94411	1	Coppia pastiglie	Pads pair	Paire plaquettes	Bremsbelagpaar	Pareja pastillas	
E	27	8000 94412	1	Vite di spurgo	Bleeding screw	Vis de curage	Reinigungsschraube	Tornillo de purga	
E	28	8000 94413	1	Parapolvere	Dust cover	Para poussière	Staubdeckel	Tapa retención polvo	
E	29	8000 94414	1	Perni pastiglie	Pin kit	Kit pivot	Bolzengruppe	Grupo perno	
E	30	8000 94415	1	Copiglia	Split pin	Goupille	Splint	Clavija	

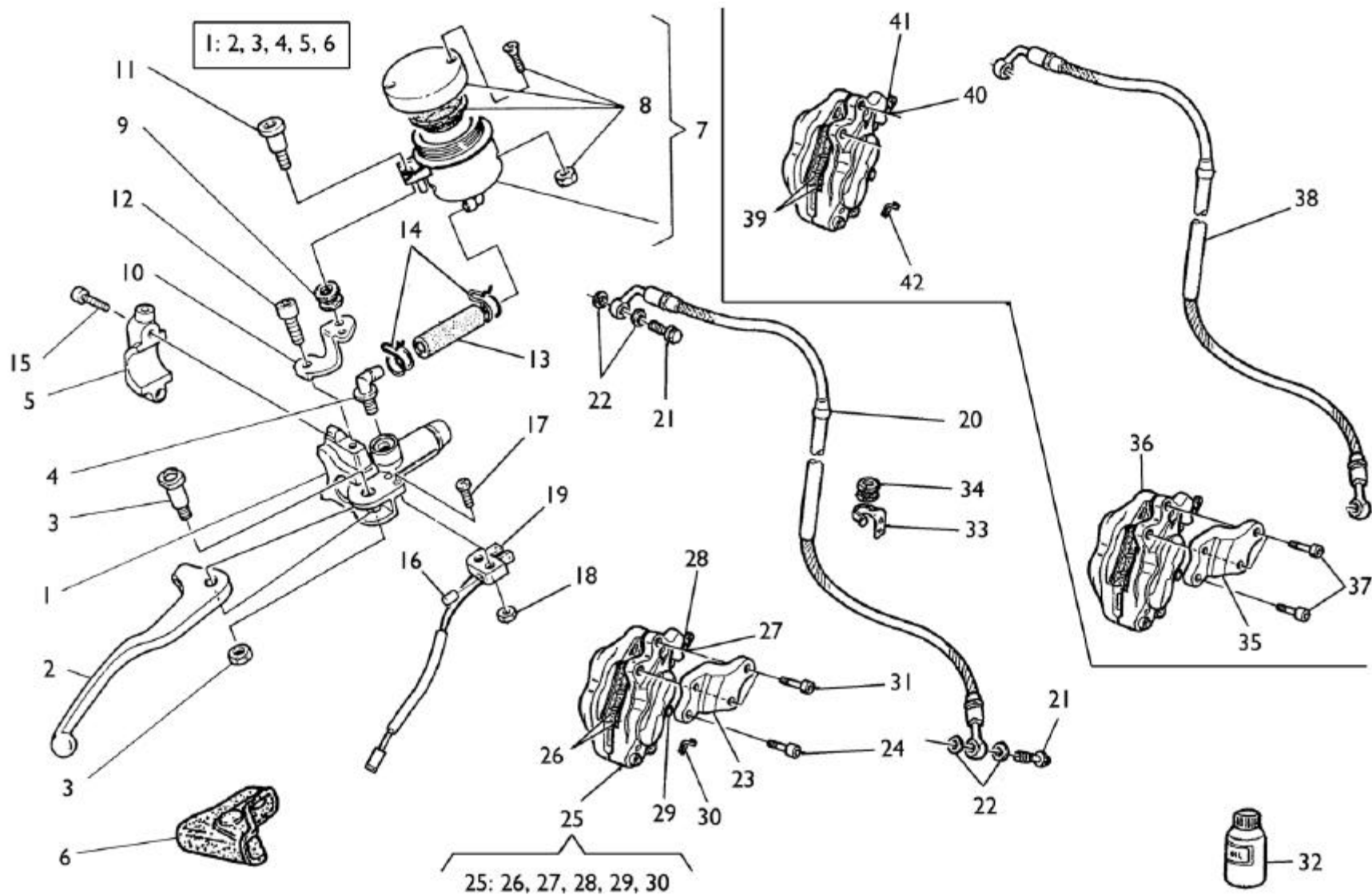

Note Notes Marka Notas	Pos. No. N. Index Pos.	N. Cod. Code No. Nr. Code Code Nr N. Cod.	Q.tà Q.ty Q.te M.ge C.ad	DENOMINAZIONE	NAME	DESIGNATION	BESHREIBUNG	DENOMINACION	Validità Validity Validité Gültig Validez
	31	8000 94060	2	Vite (M10x25mm)	Screw (M10x25mm)	Vis (M10x25mm)	Schraube (M10x25mm)	Tornillo (M10x25mmmm)	
R	32	8000 71445	1	Olio freni	Brake oil	Huile frein	Bremsöl	Aceite freni	
	33	8000 90104	1	Piastrina	Plate	Plaquette	Plättchen	Placa	
	34	8000 71806	1	Guida cavo	Cable guide	Guide câble	Kabelführung	Guía-cable	
§	35	8000 A1708	1	Piastra	Plate	Plaque	Platte	Placa	
§	36	8000 A1707	1	Pinza freno	Brake caliper	Etrier frein	Bremssattel	Pinza	
	37	8C00 62797	4	Vite (M10x35mm)	Screw (M10x35mm)	Vis (M10x35mm)	Schraube (M10x35mm)	Tornillo (M10x35mmmm)	
§	38	8000 A1706	1	Tubo mandata olio	Pipe	Tuyau	Rohr	Tubo	
§	39	8000 A2040	1	Coppia pastiglie	Pads pair	Paire plaquettes	Bremsbelagpaar	Pareja pastillas	
§	40	8000 A2041	1	Vite di spurgo	Bleeding screw	Vis de curage	Reinigungsschraube	Tornillo de purga	
§	41	8000 A2042	1	Parapolvere	Dust cover	Para poussière	Staubdeckel	Tapa retención polvo	
§	42	8000 A2043	1	Copiglia	Split pin	Goupille	Splint	Clavija	
			E	per disco 8000 95751 (ø320mm; S= 4mm- tav. 22C)	disc 8000 95751 (ø320mm; S= 4mm- drwg 22C)	disque 8000 95751 (ø320mm; S= 4mm- table 22C)	Bremsscheibe 8000 95751 (ø320mm; S= 4mm- bild 22C)	disco 8000 95751 (ø320mm; S= 4mm- tav. 22C)	
			§	per disco 8000 A1709 (ø320mm; S= 5mm- tav. 22C)	disc 8000 A1709 (ø320mm; S= 5mm- drwg 22C)	disque 8000 A1709 (ø320mm; S= 5mm- table 22C)	Bremsscheibe 8000 A1709 (ø320mm; S= 5mm- bild 22C)	disco 8000 A1709 (ø320mm; S= 5mm- tav. 22C)	

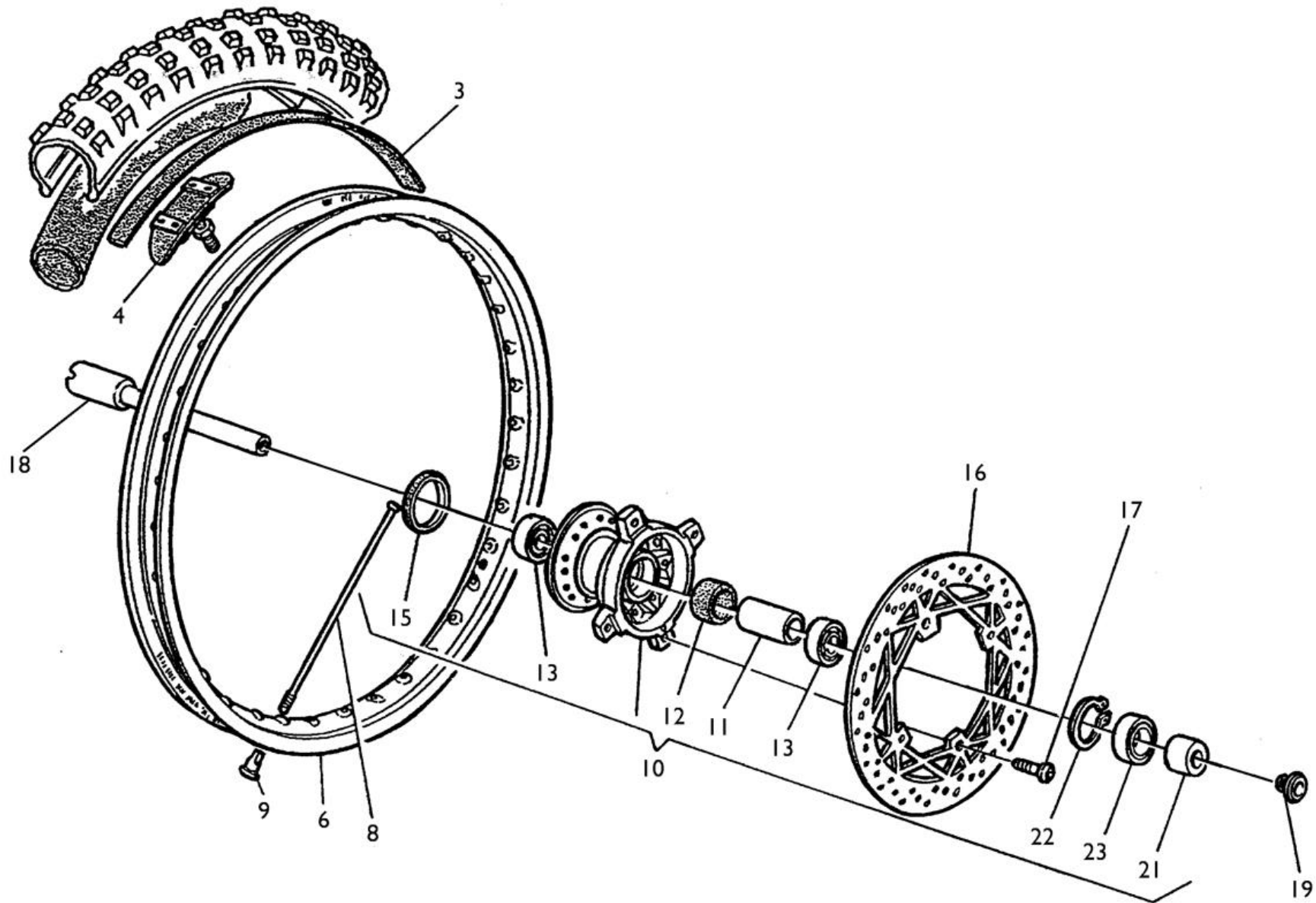

Note Notes Marka Notas	Pos. No. N. Index Pos.	N. Cod. Code No. Nr. Code Code Nr N. Cod.	Q.tà Q.ty Q.te M.ge C.ad	DENOMINAZIONE	NAME	DESIGNATION	BESHREIBUNG	DENOMINACION	Validità Validity Validité Gültig Validez
	3	8000 13346	1	Fascia copriraggi	Rim strip	Bande	Band	Banda	
	4	8000 49036	1	Staffa fermacopertone	Bracket	Etrier	Buegel	Brida	
	6	8A00 53504	1	Cerchio (1,6x21")	Rim (1,6x21")	Jante (1,6x21")	Felge (1,6x21")	Llanta (1,6x21")	
	8	8000 A0080	36	Raggio	Spoke	Bras	Speiche	Radio	
	9	8000 A0081	36	Nipplo	Nipple	Nipple	Nippel	Nipple	
	10	8000 96838	1	Mozzo completo	Hub assy	Moyeau compl.	Radnabe, Kpl.	Cubo compl.	
	11	8000 96928	1	Distanziale	Spacer	Entretoise	Distanzstück	Separador	
	12	8000 92797	1	Portadistanziale	Spacer holder	Porte-entretoise	Abstandstückhalter	Porta-distancial	
	13	8000 84938	2	Cuscinetto a sfere (ø25xØ42x9 mm)	Ball bearing (ø25xØ42x9 mm)	Roulement à billes (ø25xØ42x9 mm)	Kugellager (ø25xØ42x9 mm)	Cojinete de bolas (ø25xØ42x9 mm)	
	15	8A00 92986	1	Anello di tenuta (ø28xØ50x5 mm)	Seal ring (ø28xØ50x5 mm)	Bague d'étanchéité (ø28xØ50x5 mm)	Dichtungsring (ø28xØ50x5 mm)	Anillo de retención (ø28xØ50x5 mm)	
	16	8000 99632	1	Disco freno (Ø260 mm)	Brake disc (Ø260 mm)	Disque frein (Ø260 mm)	Bremsscheibe (Ø260 mm)	Disco freno (Ø260 mm)	
	17	8A00 55241	4	Vite	Screw	Vis	Schraube	Tornillo	
	18	8000 96932	1	Perno ruota	Pin	Pivot	Bolzen	Perno ruoda	
	19	8000 96933	1	Vite	Screw	Vis	Schraube	Tornillo	
	21	8000 96930	1	Distanziale	Spacer	Entretoise	Distanzstück	Separador	
	22	66N0 21270	1	Anello SEEGER	SEEGER ring	Anneau SEEGER	Ring SEEGER	Anillo SEEGER	
	23	8000 22966	1	Anello di tenuta (ø32xØ42x7 mm)	Seal ring (ø32xØ42x7 mm)	Bague d'étanchéité (ø32xØ42x7 mm)	Dichtungsring (ø32xØ42x7 mm)	Anillo de retención (ø32xØ42x7 mm)	

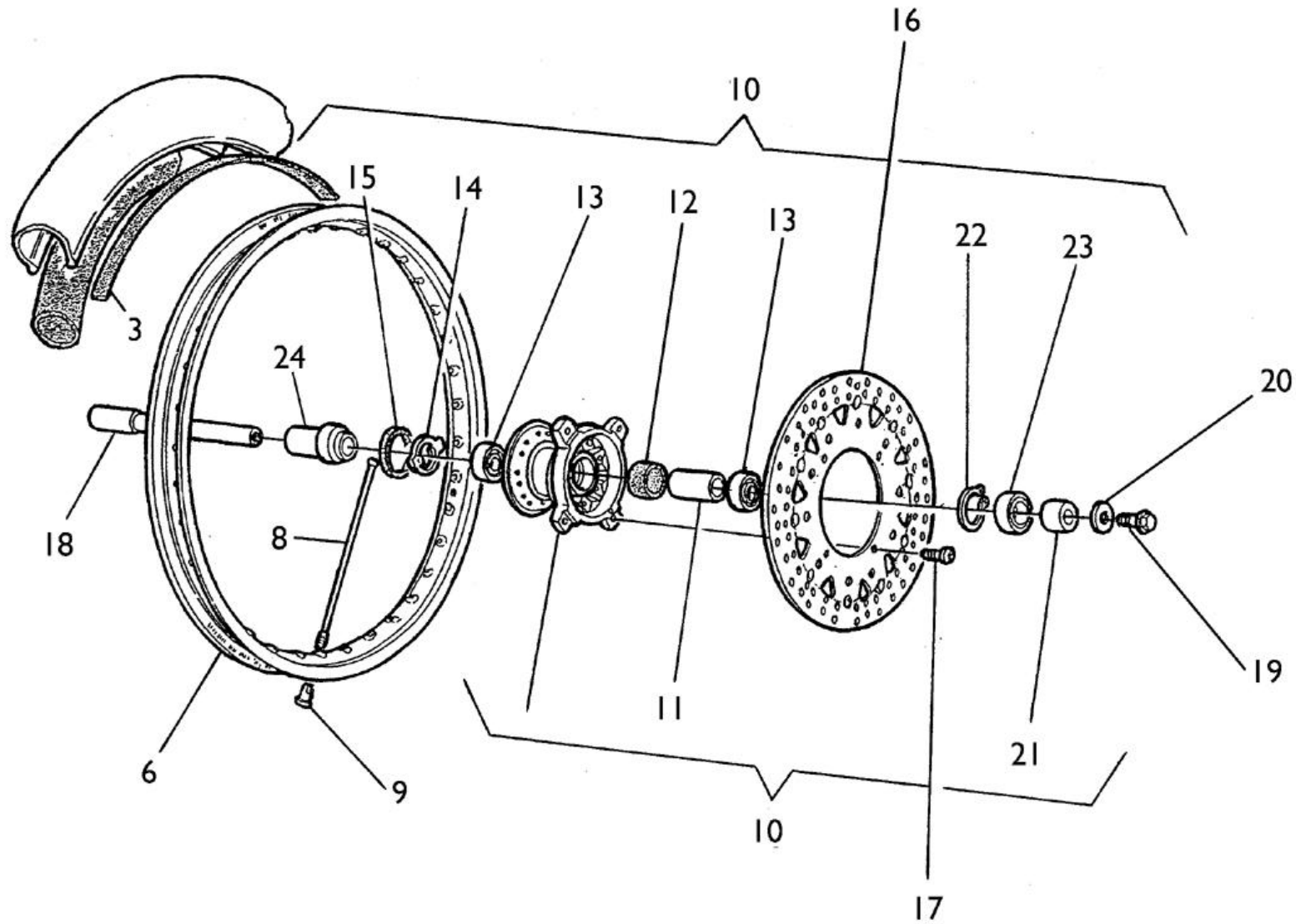

Note Notes Marka Notas	Pos. No. N. Index Pos.	N. Cod. Code No. Nr. Code Code Nr N. Cod.	Q.tà Q.ty Q.te M.ge C.ad	DENOMINAZIONE	NAME	DESIGNATION	BESHREIBUNG	DENOMINACION	Validità Validity Validité Gültig Validez
	3	8B00 82879	1	Fascia copriraggi	Rim strip	Bande	Band	Banda	
	6	8000 94709	1	Cerchio (3,5x17")	Rim (3,5x17")	Jante (3,5x17")	Felge (3,5x17")	Llanta (3,5x17")	
	8	8000 94754	36	Raggio	Spoke	Bras	Speiche	Radio	
	9	69N4 29004	36	Nipplo	Nipple	Nipple	Nippel	Nipple	
	10	8A00 94696	1	Mozzo completo	Hub assy	Moyeau compl.	Radnabe, Kpl.	Cubo compl.	
	11	8000 95629	1	Distanziale	Spacer	Entretoise	Distanzstück	Separador	
	12	8000 92797	1	Portadistanziale	Spacer holder	Porte-entretoise	Abstandstückhalter	Porta-distancial	
	13	8A00 39651	2	Cuscinetto a sfere (ø20xø42x12mm)	Ball bearing (ø20xø42x12mm)	Roulement à billes (ø20xø42x12mm)	Kugellager (ø20xø42x12mm)	Cojinete de bolas (ø20xø42x12mm)	
	14	8000 77884	1	Anello trascinatoro	Ring	Bague	Ring	Anillo	
	15	8000 51957	1	Anello di tenuta (ø40xø50x4mm)	Seal ring (ø40xø50x4mm)	Bague d'étanchéité (ø40xø50x4mm)	Dichtungsring (ø40xø50x4mm)	Anillo de retención (ø40xø50x4mm)	
E	16	8000 95751	1	Disco freno (ø320mm; S= 4mm)	Brake disc (ø320mm; S= 4mm)	Disque frein (ø320mm; S= 4mm)	Bremsscheibe (ø320mm; S= 4mm)	Disco freno (ø320mm; S= 4mm)	
§	16	8000 A1709	1	Disco freno (ø320mm; S= 5mm)	Brake disc (ø320mm; S= 5mm)	Disque frein (ø320mm; S= 5mm)	Bremsscheibe (ø320mm; S= 5mm)	Disco freno (ø320mm; S= 5mm)	
	17	8A00 92876	4	Vite	Screw	Vis	Schraube	Tornillo	
	18	8D00 75042	1	Perno ruota	Pin	Pivot	Bolzen	Perno rueda	
	19	8000 48773	1	Vite	Screw	Vis	Schraube	Tornillo	
	20	8000 48772	1	Rosetta piana	Washer	Rondelle	Scheibe	Arandela	
	21	8000 88889	1	Parapolvere	Dust guard	Pare poussière	Staubdeckel	Tapa retención polvo	
	22	66N0 21270	1	Anello SEEGER	SEEGER ring	Anneau SEEGER	Ring SEEGER	Anillo SEEGER	
	23	8B00 92792	1	Distanziale	Spacer	Entretoise	Distanzstück	Separador	
	24	8000 77749	1	Distanziale	Spacer	Entretoise	Distanzstück	Separador	
			E	per pinza n°25 tavola 22A	caliper n°25 drawing 22A	etrier n°25 table 22A	Bremssattel n°25 bild 22A	pinza n°25 tabla 22A	
			§	per pinza n°36 tavola 22A	caliper n°36 drawing 22A	etrier n°36 table 22A	Bremssattel n°36 bild 22A	pinza n°36 tabla 22A	

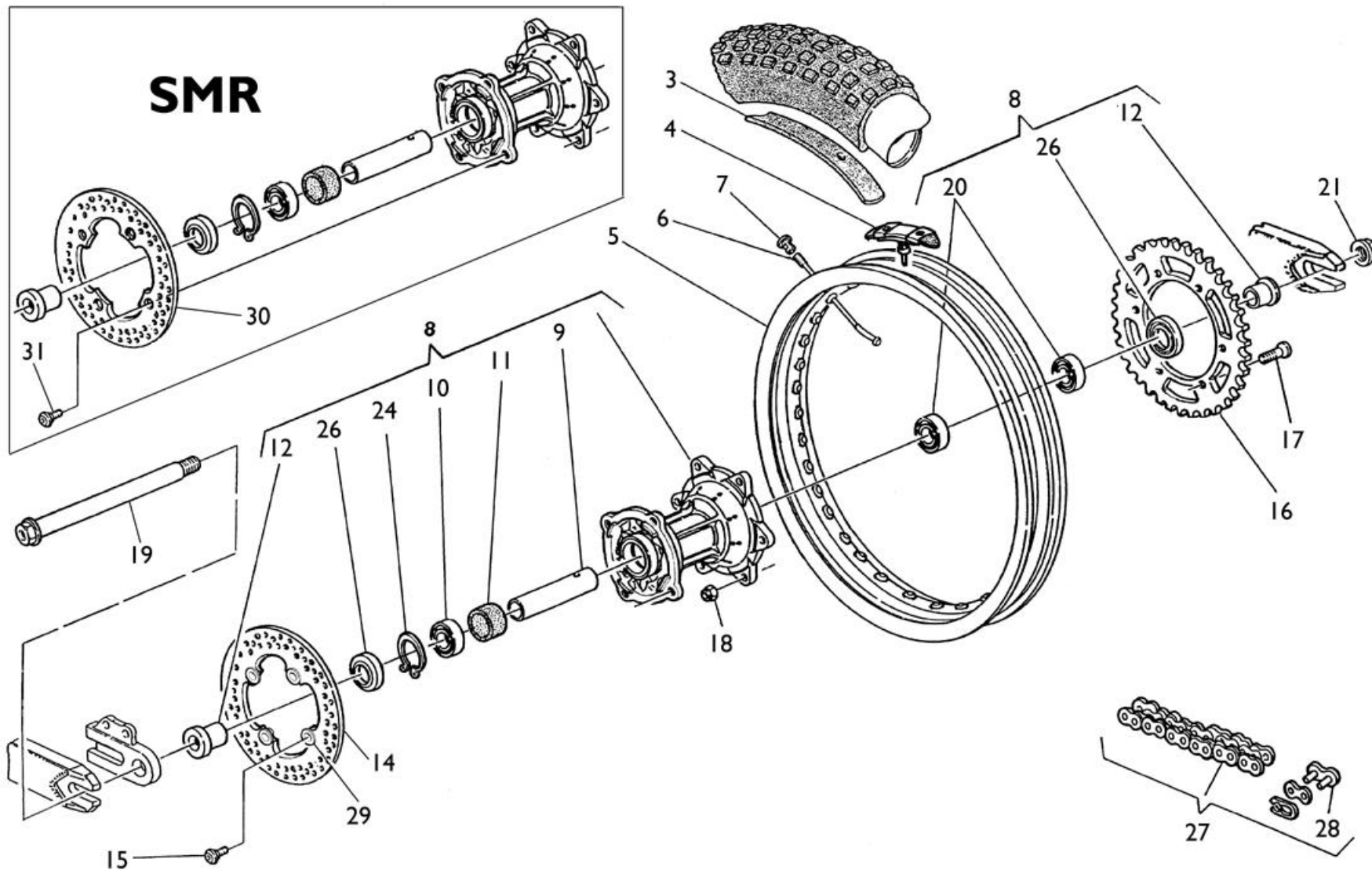

Note Notes Marka Notas	Pos. No. Index Pos.	N. Cod. Code No. Nr. Code Code Nr N. Cod.	Q.tà Q.ty Q.te M.ge C.ad	DENOMINAZIONE	NAME	DESIGNATION	BESHREIBUNG	DENOMINACION	Validità Validity Validité Gültig Validez
W	3	8000 01688	1	Fascia copriraggi	Rim strip	Bande	Band	Banda	
M	3	8B00 82879	1	Fascia copriraggi	Rim strip	Bande	Band	Banda	
W	4	8000 54073	1	Staffa fermacopertone	Bracket	Etrier	Buegel	Brida	
W	5	8A00 55860	1	Cerchio (2,15 x 18")	Rim (2,15 x 18")	Jante (2,15 x 18")	Felge (2,15 x 18")	Llanta (2,15 x 18")	
M	5	8000 94713	1	Cerchio (4,25 x 17")	Rim (4,25 x 17")	Jante (4,25 x 17")	Felge (4,25 x 17")	Llanta (4,25 x 17")	
W	6	8000 A0085	36	Raggio	Spoke	Bras	Speiche	Radio	
M	6	8000 94757	18	Raggio lato SINISTRO	Spoke (L.H. side)	Bras (cote gauche)	Speiche (linke Seite)	Radio (lado izquierdo)	
M	6	8000 95341	18	Raggio lato DESTRO	Spoke (R.H. side)	Bras (cote gauche)	Speiche (rechte Seite)	Radio (lado derecho)	
W	7	8000 A0086	36	Nipplo	Nipple	Nipple	Nippel	Nipple	
M	7	69N4 29005	36	Nipplo	Nipple	Nipple	Nippel	Nipple	
W	8	8000 96937	1	Mozzo completo	Hub assy	Moyeau compl.	Radnabe, Kpl.	Cubo compl.	
M	8	8000 97593	1	Mozzo completo	Hub assy	Moyeau compl.	Radnabe, Kpl.	Cubo compl.	
W	9	8000 92414	1	Distanziale	Spacer	Entretoise	Distanzstück	Separador	
M	9	8A00 86938	1	Distanziale	Spacer	Entretoise	Distanzstück	Separador	
	10	8B00 26846	1	Cuscinetto(ø25xø47x16 mm)	Bearing (ø25xø47x16 mm)	Roulement (ø25xø47x16 mm)	Kugellager (ø25xø47x16 mm)	Cojinete (ø25xø47x16 mm)	
A	10	8D00 26846	1	Cuscinetto(ø25xø47x16 mm)	Bearing (ø25xø47x16 mm)	Roulement (ø25xø47x16 mm)	Kugellager (ø25xø47x16 mm)	Cojinete (ø25xø47x16 mm)	
	11	8000 92797	1	Porta distanziale	Spacer	Entretoise	Distanzstück	Separador	
	12	8000 96938	2	Distanziale	Spacer	Entretoise	Distanzstück	Separador	
WC	14	8000 A0692	1	Disco freno (ø220 mm)	Brake disc (ø220 mm)	Disque frein (ø220 mm)	Bremsscheibe (ø220 mm)	Disco freno (ø220 mm)	
WC	15	8000 62726	4	Vite	Screw	Vis	Schraube	Tornillo	
R	16	8A00 96837	1	Corona (Z = 47)	Ring gear (Z = 47)	Couronne (Z = 47)	Kranz (Z = 47)	Corona (Z = 47)	
WM	16	8B00 96837	1	Corona (Z = 48)	Ring gear (Z = 48)	Couronne (Z = 48)	Kranz (Z = 48)	Corona (Z = 48)	
R	16	8C00 96837	1	Corona (Z = 49)	Ring gear (Z = 49)	Couronne (Z = 49)	Kranz (Z = 49)	Corona (Z = 49)	
R	16	8D00 96837	1	Corona (Z = 50)	Ring gear (Z = 50)	Couronne (Z = 50)	Kranz (Z = 50)	Corona (Z = 50)	
R	16	8E00 96837	1	Corona (Z = 51)	Ring gear (Z = 51)	Couronne (Z = 51)	Kranz (Z = 51)	Corona (Z = 51)	
R	16	8F00 96837	1	Corona (Z = 52)	Ring gear (Z = 52)	Couronne (Z = 52)	Kranz (Z = 52)	Corona (Z = 52)	
	17	8C00 40796	6	Vite	Screw	Vis	Schraube	Tornillo	
	18	8000 43928	6	Dado	Nut	Ecrou	Mutter	Tuierca	
	19	8000 96940	1	Perno	Pin	Pivot	Bolzen	Perno	
	20	8A00 26846	2	Cuscinetto (ø25xø47x12 mm)	Bearing (ø25xø47x12 mm)	Roulement (ø25xø47x12 mm)	Kugellager (ø25xø47x12 mm)	Cojinete (ø25xø47x12 mm)	

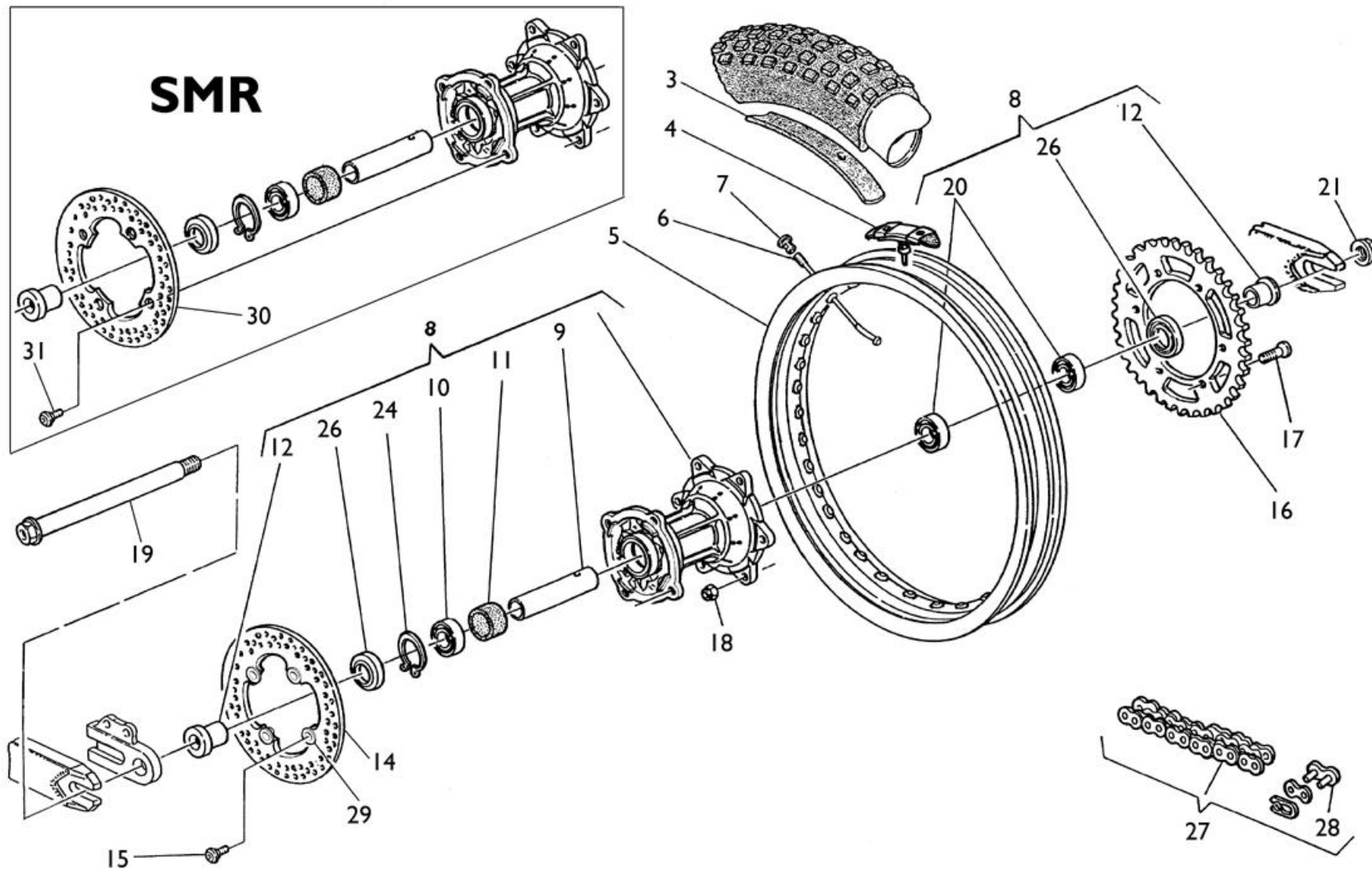

Note Notes Marka Notas	Pos. No. N. Index Pos.	N. Cod. Code No. Nr. Code Code Nr N. Cod.	Q.tà Q.ty Q.te M.ge C.ad	DENOMINAZIONE	NAME	DESIGNATION	BESHREIBUNG	DENOMINACION	Validità Validity Validité Gültig Validez
A	20	8C00 26846	2	Cuscinetto (ø25xø47x12 mm)	Bearing (ø25xø47x12 mm)	Roulement (ø25xø47x12 mm)	Kugellager (ø25xø47x12 mm)	Cojinete (ø25xø47x12 mm)	
	21	8000 93072	1	Dado	Nut	Ecrou	Mutter	Tuerca	
	24	66N0 21272	1	Anello SEEGER	SEEGER ring	Anneau SEEGER	Ring SEEGER	Anillo SEEGER	
	26	8000 89572	2	Anello di tenuta (ø32xø47x7 mm)	Seal ring (ø32xø47x7 mm)	Bague d'étanchéité (ø32xø47x7 mm)	Dichtungsring (ø32xø47x7 mm)	Anillo de retención (ø32xø47x7 mm)	
WM	27	8A00 65442	1	Catena 5/8"x6,5 (116 maglie)	Chain 5/8"x6,5 (116 link)	Chaîne 5/8"x6,5 (116 maillon)	Kette 5/8"x6,5 (116 Schake)	Cadena 5/8"x6,5 (116 malla)	
WMA	27	8C00 79783	1	Catena 5/8"x6,5 (116 maglie)	Chain 5/8"x1/4"(116 link)	Chaîne 5/8"x6,5 (116 maillon)	Kette 5/8"x6,5 (116 Schake)	Cadena 5/8"x6,5 (116 malla)	
WM	28	8000 65464	1	Giunto	Coupling	Joint	Kupplung	Junta	
WMA	28	8000 79789	1	Giunto	Coupling	Joint	Kupplung	Junta	
WC	29	8000 A0693	4	Bussola	Bushing	Douille	Buchse	Manguito	
M	30	8000 88887	1	Disco freno(ø220 mm)	Brake disc (ø220 mm)	Disque frein (ø220 mm)	Bremsscheibe (ø220 mm)	Disco freno (ø220 mm)	
M	31	8000 55878	4	Vite	Screw	Vis	Schraube	Tornillo	

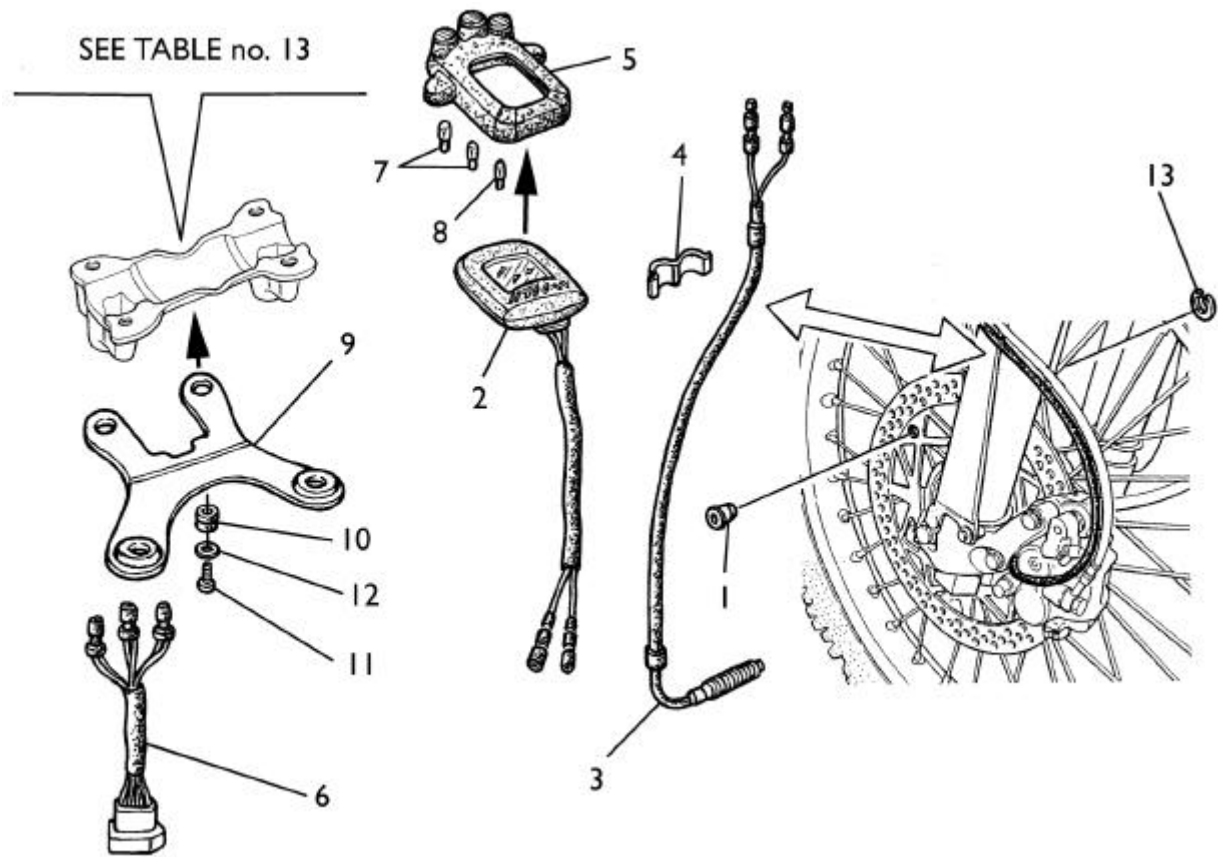

Note Notes Marka Notas	Pos. No. Index Pos.	N. Cod. Code No. Nr. Code Code Nr N. Cod.	Q.tà Q.ty Q.te M.ge C.ad	DENOMINAZIONE	NAME	DESIGNATION	BESHREIBUNG	DENOMINACION	Validità Validity Validité Gültig Validez
WX	1	8000 99775	1	Magnete	Magnet	Amiant	Magnet	Imán	
MX	1	8000 A0843	1	Magnete	Magnet	Amiant	Magnet	Imán	
X	1	8000 99775	1	Magnete	Magnet	Amiant	Magnet	Imán	
X	2	8000 99650	1	Contachilometri digitale	Digital speedometer	Compteur-km digital	Digital Tachometer	Cuenta-kilómetros digital	
X	3	8000 99652	1	Sensore magnetico	Sensor	Palpeur	Sensor	Sensor	
X	4	8000 A0664	2	Molletta	Clip	Collier	Schelle	Banda	
X	5	8000 A0883	1	Supporto spie	Holder	Support	Halterung	Soporte	
X	6	8000 99651	1	Gruppo cavi	Cable assy	Cables compl.	Kabel Kpl.	Grupo cables	
X	7	8000 20602	2	Lampadina (12V-1,2 W)	Lamp (12V-1,2 W)	Lampe (12V-1,2 W)	Lampe (12V-1,2 W)	Lamparilla (12V-1,2 W)	
X	8	8000 60033	2	Lampadina (12V-2 W)	Lamp (12V-2 W)	Lampe (12V-2 W)	Lampe (12V-2 W)	Lamparilla (12V-2 W)	
X	9	8000 99774	1	Piastra	Plate	Plaque	Platte	Placa	
X	10	8000 41862	2	Passacavo	Fairlead	Passe-câble	Kabelführung	Prensa-cable	
X	11	60N4 98033	2	Vite	Screw	Vis	Schraube	Tornillo	
X	12	62N4 15547	2	Rosetta	Washer	Rondelle	Scheibe	Arandela	
WX	13	66N0 21200	1	Anello elastico	Snap ring	Bague d'arret	Haltering	Anillo elástico	
MX	13	66N0 21197	1	Anello elastico	Snap ring	Bague d'arret	Haltering	Anillo elástico	

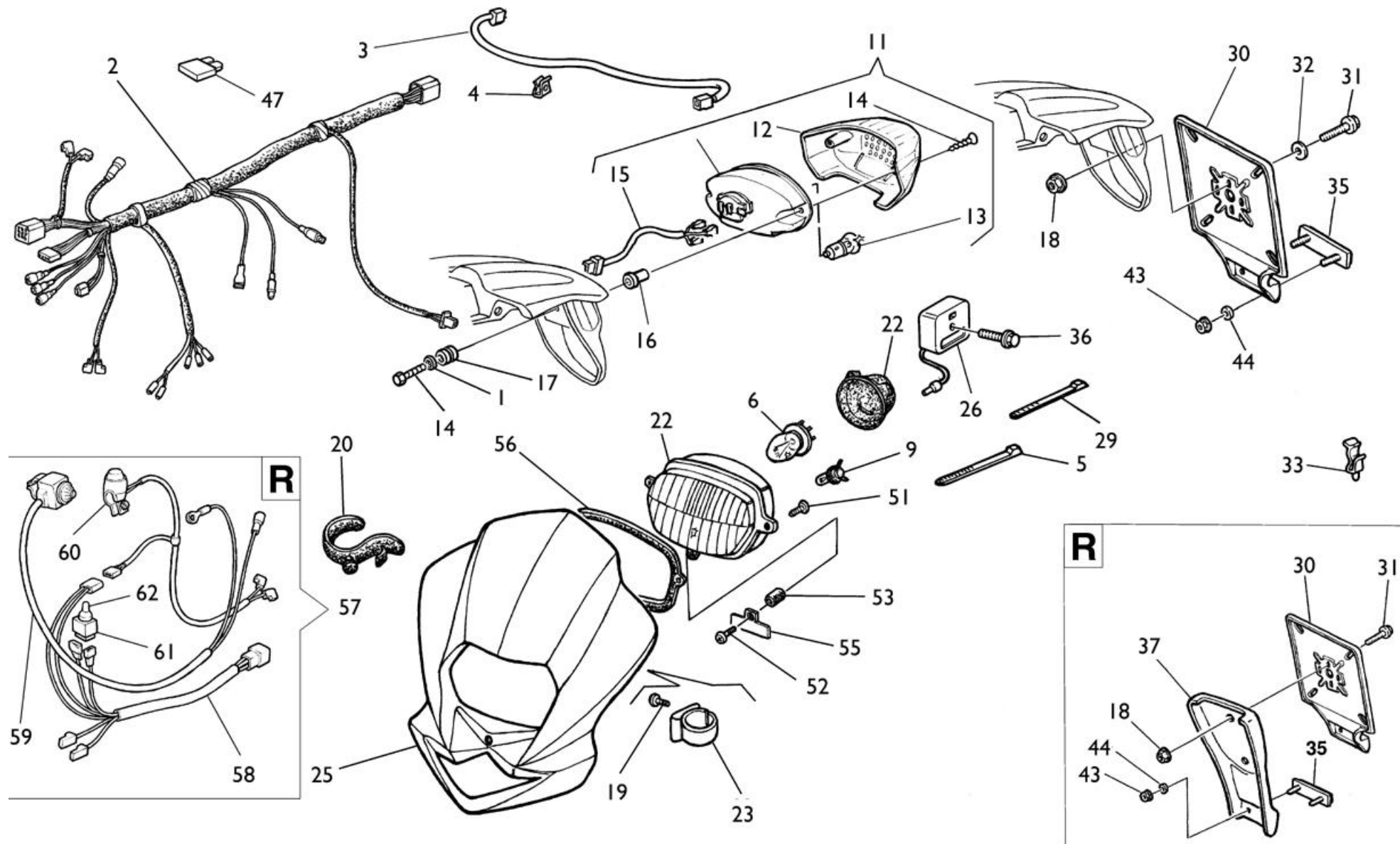

Note Notes Notas	Pos. No. Index Pos.	N. Cod. Code No. Nr. Code Code Nr N. Cod.	Q.tà Q.ty Q.te M.ge C.ad	DENOMINAZIONE	NAME	DESIGNATION	BESHREIBUNG	DENOMINACION	Validità Validity Validité Gültig Validez
X	1	8A00 20373	2	Rosetta piana	Washer	Rondelle	Scheibe	Arandela	
X	2	8000 A0627	1	Gruppo principale cavi	Cable assy	Cables compl.	Kabel Kpl.	Grupo principal cables	
X	3	8000 70277	1	Cavo posteriore	Cable	Cable	Kabel	Cable	
X	4	8000 72494	1	Passacavo	Fairlead	Passe-câble	Kabelführung	Prensa-cable	
	5	8000 34002	5	Fascetta	Clamp	Collier	Schelle	Banda	
X	6	8000 20137	1	Lampada (12V-35/35 W)	Lamp (12V-35/35 W)	Lampe (12V-35/35 W)	Lampe (12V-35/35 W)	Lamparilla (12V-35/35 W)	
X	9	8000 26694	1	Lampada (12V-3 W)	Lamp (12V-3 W)	Lampe (12V-3 W)	Lampe (12V-3 W)	Lamparilla (12V-3 W)	
X	11	8A00 88873	1	Fanale posteriore completo	Tail light	Feux arrière	Hinterleuchte	Faro trasero	
X	12	8A00 94119	1	Lente	Lens	Loupe	Linse	Lente	
X	13	8A00 18246	1	Lampada (12V-5/12 W)	Lamp (12V-5/12 W)	Lampe (12V-5/12 W)	Lampe (12V-5/12 W)	Lamparilla (12V-5/12 W)	
X	14	8000 A0953	2	Vite	Screw	Vis	Schraube	Tornillo	
X	15	8000 94121	1	Cablaggio	Cable	Cable	Kabel	Cable	
X	16	8A00 94120	2	Distanziale	Spacer	Entretoise	Distanzstück	Separador	
X	17	8000 18048	2	Gommino	Rubber pad	Pièce caoutchouc	Gummistück	Junta de goma	
X	18	8000 44240	2	Dado	Nut	Ecrou	Mutter	Tuerca	
X	19	8A00 37283	2	Vite	Screw	Vis	Schraube	Tornillo	
X	20	8000 88602	4	Elastico	Elastic	Elastique	Elastisch	Elástico	
X	22	8000 A0278	1	Gruppo ottico	Optical group	Groupe optique	Optische Gruppe	Grupo óptico	
X	23	8000 A0864	1	Anello	Ring	Bague	Ring	Anilo	
WX	25	8000 A0233	1	Cupolino	Fairing	Carenage	Verkleidung	Cúpula	
MX	25	8000 A0233	1	Cupolino (codice colore E)	Fairing (color code E)	Carenage (code couleur E)	Verkleidung (Code Farbe E)	Cúpula (còdigo colòr E)	
MX	25	80A0 A0233	1	Cupolino (codice colore G)	Fairing (color code G)	Carenage (code couleur G)	Verkleidung (Code Farbe G)	Cúpula (còdigo colòr G)	
Y	26	8000 79571	1	Regolatore di tensione	Voltage rectifier	Régulateur de tension	Spannungsregler	Regulador de tensión	
X	29	8000 56444	8	Fascetta (L=188 mm)	Clamp (L=188 mm)	Collier (L=188 mm)	Schelle (L=188 mm)	Banda (L=188 mm)	
X	30	8000 94595	1	Portatarga	Licence plate holder	Portebalai	Schildträger	Portamatricula	
X	31	8000 62727	2	Vite	Screw	Vis	Schraube	Tornillo	

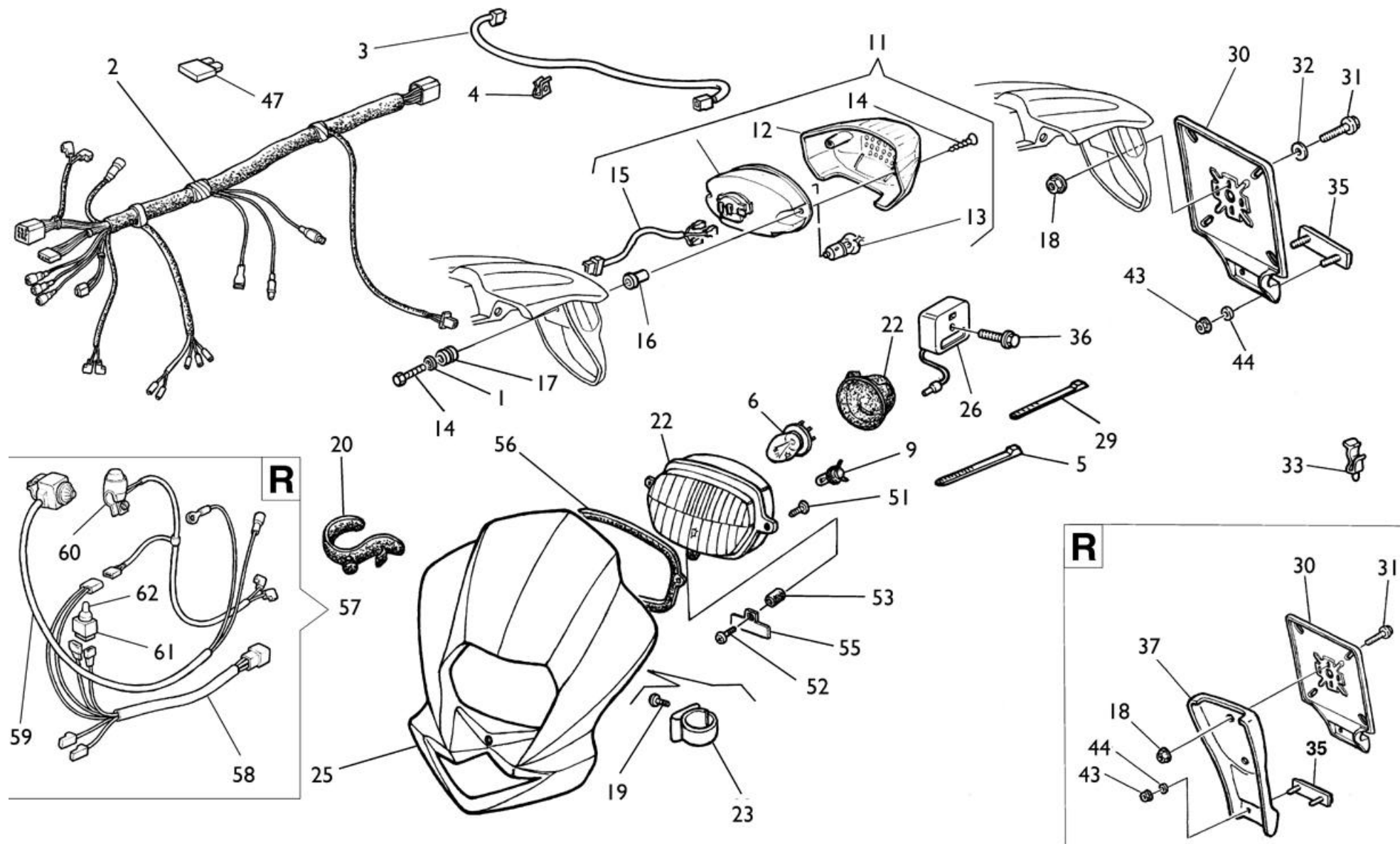

Note Notes Marka Notas	Pos. No. Index Pos.	N. Cod. Code No. Nr. Code Code Nr N. Cod.	Q.tà Q.ty M.ge C.ad	DENOMINAZIONE	NAME	DESIGNATION	BESHREIBUNG	DENOMINACION	Validità Validity Validité Gültig Validez
X	32	8000 56359	2	Vite	Screw	Vis	Schraube	Tornillo	
X	33	8000 58207	2	Passacavo	Fairlead	Passe-câble	Kabelführung	Prensa-cable	
X	35	8000 73834	1	Catadiottro	Reflector	Catadioptrique	Ruckstrahler	Catafaros	
X	36	8000 62730	1	Vite	Screw	Vis	Schraube	Tornillo	
RX	37	8000 94342	1	Paraspruzzi	Rear end	Terminal	Hinterkiff	Para rociada	
X	38	8A00 67997	2	Vite	Screw	Vis	Schraube	Tornillo	
X	40	8000 87696	1	Piastra	Plate	Plaque	Platte	Placa	
X	43	8000 40717	2	Dado	Nut	Ecrou	Mutter	Tuerca	
X	44	62N1 15547	2	Rosetta	Washer	Rondelle	Scheibe	Arandela	
X	46	8000 68690	1	Fascetta	Clamp	Collier	Schelle	Banda	
X	47	8000 47472	1	Fusibile (15A)	Fuse (15A)	Fusible (15A)	Sicherung (15A)	Fusible (15A)	
X	50	8AA0 55705	2	Linguetta fermacavo	Retainer	Arret	Klammer	Abrazadera de sujeción	
X	51	60N4 98033	2	Vite	Screw	Vis	Schraube	Tornillo	
X	52	8000 24962	1	Vite	Screw	Vis	Schraube	Tornillo	
X	53	8000 A1051	1	Distanziale	Spacer	Entretoise	Distanzstück	Separador	
X	54	8000 62725	1	Vite	Screw	Vis	Schraube	Tornillo	
X	55	8000 A1052	1	Piastrina	Plate	Plaque	Platte	Placa	
X	56	8000 A1053	1	Guarnizione	Gasket	Garniture	Dichtung	Junta	
RW	57	8000 A1883	1	Kit cablaggio RACING	RACING main wiring harness	Kit cables RACING	RACING Kabel Kit	Kit grupo cables RACING	
RW	58	8000 A1219	1	Cablaggio RACING	RACING wiring	Cables RACING	RACING Kabel	Cables RACING	
RW	59	8000 96828	1	Pulsante arresto motore	Engine stop button	Poussoir arret moteur	Knopf	Pulsador parada motor	
RW	60	8000 94145	1	Pulsante avvisatore acustico	Horn button	Poussoir avertisseur acoust.	Knopf	Pulsador avisador acustico	
RW	61	8000 93221	1	Interruttore luci	Lights switch	Poussoir feu	Schalter	Pulsador luces	
RW	62	8000 71755	1	Cappucio	Rubber cap	Capuchon	Gummihäube	Capuchón	

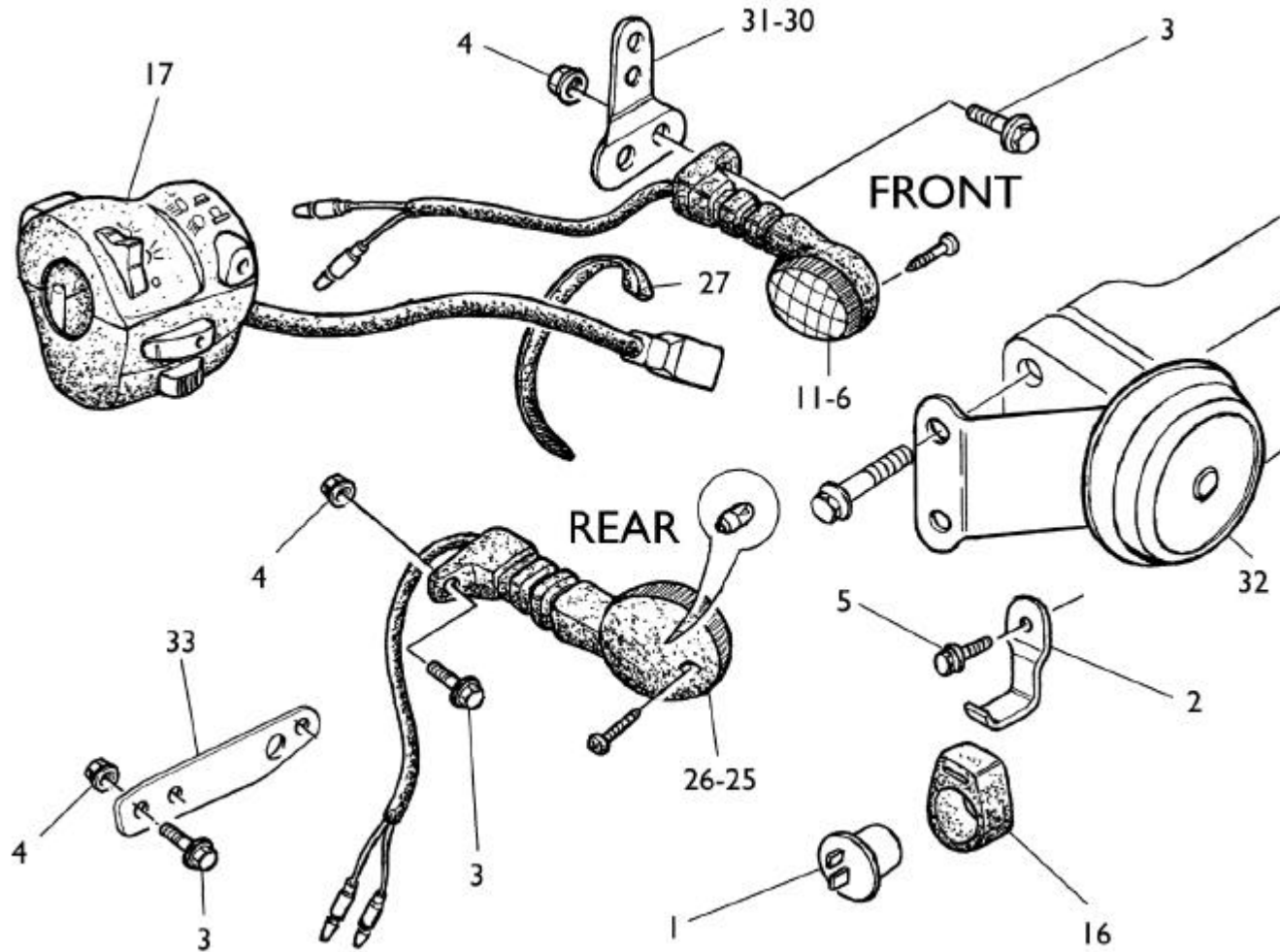

Note Notes Markes Notas	Pos. No. N. Index Pos.	N. Cod. Code No. Nr. Code Code Nr N. Cod.	Q.tà Q.ty Q.te M.ge C.ad	DENOMINAZIONE	NAME	DESIGNATION	BESHREIBUNG	DENOMINACION	Validità Validity Validité Gültig Validez
DX	1	8000 57511	1	Intermittenza	Flash device	Intermittence	Blinkgeber	Intermitencia	
DX	2	8000 A0678	1	Piastra per intermittenza	Plate (Flash device)	Plaque (Intermittence)	Platte (Blinkgeber)	Placa (Intermitencia)	
DX	3	8000 62727	8	Vite (M6x16 mm)	Screw (M6x16 mm)	Vis (M6x16 mm)	Schraube (M6x16 mm)	Tornillo (M6x16 mm)	
DX	4	8000 44240	8	Dado	Nut	Ecrou	Mutter	Tuerca	
DX	5	8000 67997	2	Vite	Screw	Vis	Schraube	Tornillo	
DX	6	8000 A0227	1	Indicatore anteriore DX	Blinker R	Clignotant D	Blinker R	Intermitente D	
DX	11	8000 A0228	1	Indicatore anteriore SX	Blinker L	Clignotant G	Blinker L	Intermitente I	
DX	16	8000 37599	1	Supporto elastico	Support	Support	Halterung	Soporte	
X	17	8000 A0634	1	Commutatore compl.	Switch compl.	Commutateur compl.	Kombischalter kpl.	Conmutador compl.	
	17	8000 A0747	1	Commutatore compl. (J)	Switch compl. (J)	Commutateur compl. (J)	Kombischalter kpl. (J)	Conmutador compl. (J)	
DX	25	8000 A0229	1	Indicatore posteriore DX	Blinker R	Clignotant D	Blinker R	Intermitente D	
DX	26	8000 A0230	1	Indicatore posteriore SX	Blinker L	Clignotant G	Blinker L	Intermitente I	
	27	8000 71578	2	Fascetta	Clamp	Collier	Schelle	Banda	
DX	30	8000 93011	1	Piastrina DX	R.H.Plate	Plaque D.	R. Platte	Placa D.	
DX	31	8A00 93011	1	Piastrina SX	L.H.Plate	Plaque G.	L. Platte	Placa I.	
DX	32	8000 90107	1	Avvisatore acustico	Horn	Signal acoustique	Hupe	Avisador acustico	
DX	33	8000 A0636	1	Piastrina posteriore	Rear plate	Plaque arriere	Hint. Platte	Placa trasera	

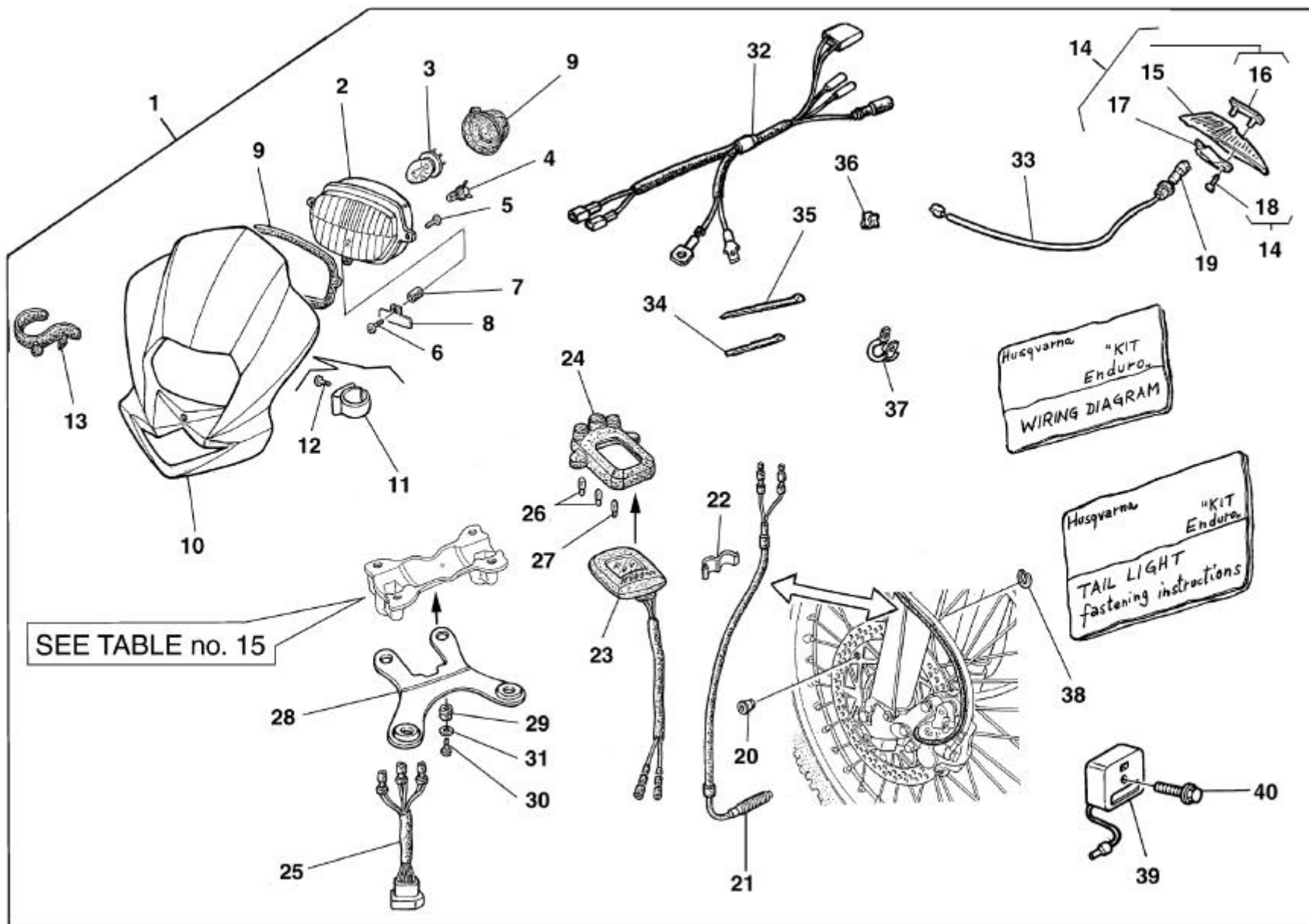

Note Notes Notas	Pos. No. Index Pos.	N. Cod. Code No. Nr. Code Code Nr N. Cod.	Q.tà Q.ty M.ge C.ad	DENOMINAZIONE	NAME	DESIGNATION	BESHREIBUNG	DENOMINACION	Validità Validity Validité Gültig Validez
W	1	8000 A0436	1	Kit ENDURO	ENDURO Kit	Groupe ENDURO	Gruppe ENDURO	Kit ENDURO	
M	1	8000 A0814	1	Kit ENDURO	ENDURO Kit	Groupe ENDURO	Gruppe ENDURO	Kit ENDURO	
	2	8000 A0278	1	Gruppo ottico	Optical group	Groupe optique	Optische Gruppe	Grupo óptico	
	3	8000 20137	1	Lampada (12V-35/35 W)	Lamp (12V-35/35 W)	Lampe (12V-35/35 W)	Lampe (12V-35/35 W)	Lamparilla (12V-35/35 W)	
	4	8000 26694	2	Lampadina (12V-3 W)	Lamp (12V-3 W)	Lampe (12V-3 W)	Lampe (12V-3 W)	Lamparilla (12V-3 W)	
	5	60N4 98033	2	Vite	Screw	Vis	Schraube	Tornillo	
	6	60N4 24962	1	Vite	Screw	Vis	Schraube	Tornillo	
	7	8000 A1051	1	Distanziale	Spacer	Entretoise	Distanzstück	Separador	
	8	8000 A1052	1	Piastrina	Plate	Plaque	Platte	Placa	
	9	8000 A1053	1	Guarnizione	Gasket	Garniture	Dichtung	Junta	
W	10	8000 A0635	1	Cupolino con decalcomanie	Fairing with decals	Carenage avec decalc.	Verkleidung mit abziehbild	Cúpula con calcomanias	
M	10	8000 A1021	1	Cupolino con decalcomanie	Fairing with decals	Carenage avec decalc.	Verkleidung mit abziehbild	Cúpula con calcomanias	
	11	8000 A0864	1	Anello	Ring	Bague	Ring	Anillo	
	12	8A00 37283	2	Vite	Screw	Vis	Schraube	Tornillo	
	13	8000 88602	4	Elastico	Elastic	Elastique	Elastisch	Elástico	
	14	8000 71213	1	Fanale posteriore completo	Tail light group	Groupe feux arrière	Hinterleuchte Gruppe	Grupo faro trasero	
	15	8000 71214	1	Fanale posteriore	Tail light	Feux arrière	Hinterleuchte	Faro trasero	
	16	8000 71215	1	Fascetta	Clamp	Collier	Schelle	Banda	
	17	8000 71216	1	Protezione	Guard	Protection	Schutz	Protección	
	18	8000 71217	2	Vite	Screw	Vis	Schraube	Tornillo	
	19	8000 26694	2	Lampadina (12V-3 W)	Lamp (12V-3 W)	Lampe (12V-3 W)	Lampe (12V-3 W)	Lamparilla (12V-3 W)	
W	20	8000 99775	1	Magnete	Magnet	Amiant	Magnet	Imán	
M	20	8000 A0843	1	Magnete	Magnet	Amiant	Magnet	Imán	
	21	8000 99652	1	Sensore magnetico	Sensor	Palpeur	Sensor	Sensor	
	22	8000 A0664	2	Molletta	Clip	Collier	Schelle	Banda	
	23	8000 99650	1	Contachilometri digitale	Digital speedometer	Compteur-km digital	Digital Tachometer	Cuenta-kilómetros digital	
	24	8000 A0883	1	Supporto spie	Holder	Support	Halterung	Soporte	
	25	8000 99651	1	Gruppo cavi	Cable assy	Cables compl.	Kabel Kpl.	Grupo cables	

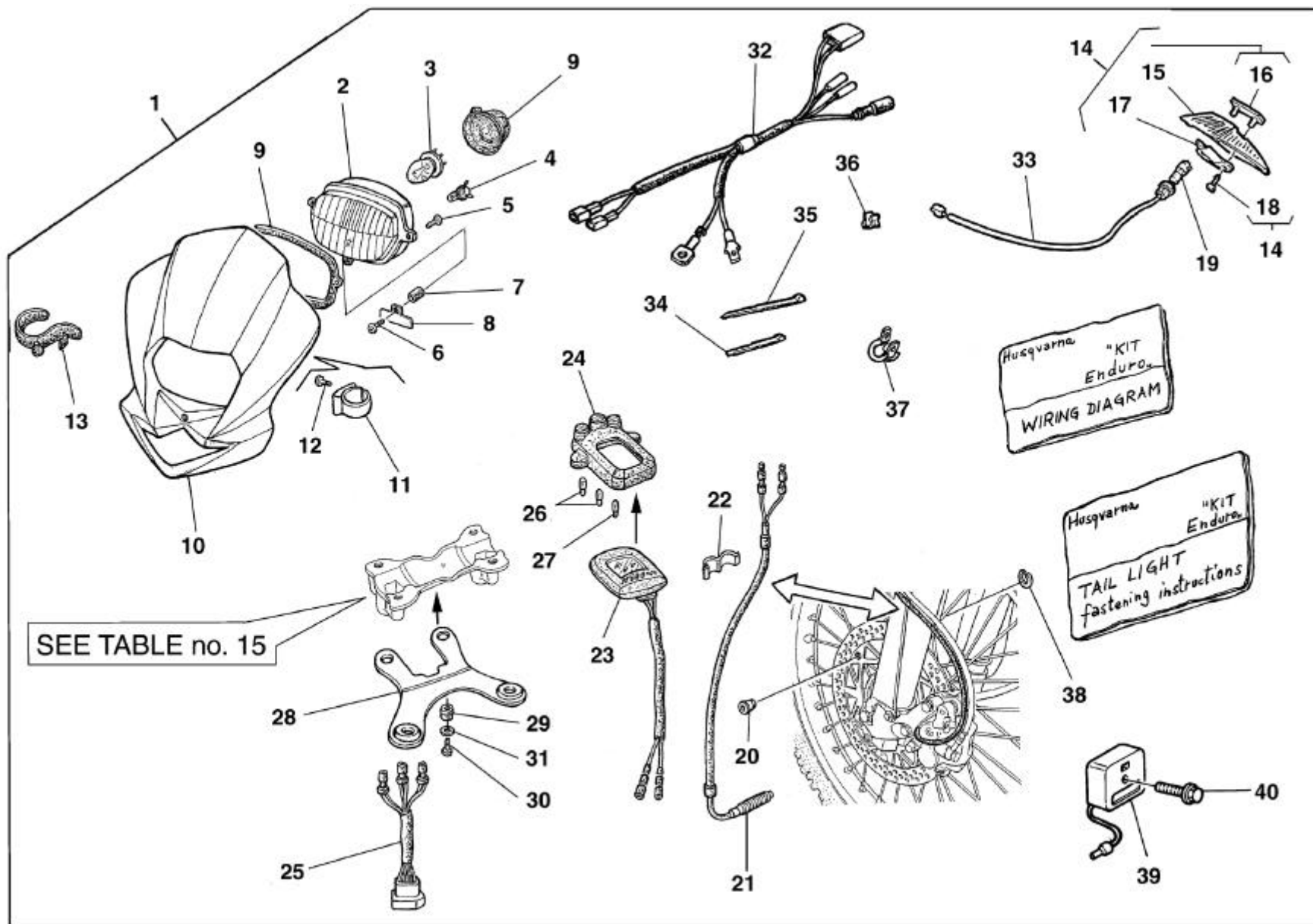

Notes Notes Marka Notas	Pos. No. N. Index Pos.	N. Cod. Code No. Nr. Code Code Nr N. Cod.	Q.tà Q.ty Q.te M.ge C.ad	DENOMINAZIONE	NAME	DESIGNATION	BESHREIBUNG	DENOMINACION	Validità Validity Validité Gültig Validez
	26	8000 20602	2	Lampadina (12V-1,2 W)	Lamp (12V-1,2 W)	Lampe (12V-1,2 W)	Lampe (12V-1,2 W)	Lamparilla (12V-1,2 W)	
	27	8000 60033	2	Lampadina (12V-2 W)	Lamp (12V-2 W)	Lampe (12V-2 W)	Lampe (12V-2 W)	Lamparilla (12V-2 W)	
	28	80A0 99774	1	Piastra	Plate	Plaque	Platte	Placa	
	29	8000 41862	2	Passacavo	Fairlead	Passe-câble	Kabelführung	Prensa-cable	
	30	60N4 98033	2	Vite	Screw	Vis	Schraube	Tornillo	
	31	62N4 15547	2	Rosetta	Washer	Rondelle	Scheibe	Arandela	
	32	8000 A0434	1	Gruppo cavi (ANTERIORE)	Cable assy (FRONT)	Cables compl. (AVANT)	Kabel Kpl. (VORDERE)	Grupo cables (DELANTERO)	
	33	8000 71221	1	Gruppo cavi (POSTERIORE)	Cable assy (REAR)	Cables compl. (ARRIERE)	Kabel Kpl. (HINTERE)	Grupo cables (TRASERO)	
	34	8000 56444	3	Fascetta (L=188mm)	Clamp (L=188mm)	Collier (L=188mm)	Schelle (L=188mm)	Banda (L=188mm)	
	35	8000 34002	2	Fascetta (L=240mm)	Clamp (L=240mm)	Collier (L=240mm)	Schelle (L=240mm)	Banda (L=240mm)	
	36	8000 72494	2	Molletta	Clip	Collier	Schelle	Banda	
	37	8000 68690	1	Fascetta	Clamp	Collier	Schelle	Banda	
W	38	66N0 21200	1	Anello elastico	Snap ring	Bague d'arret	Haltering	Anillo elástico	
M	38	66N0 21197	1	Anello elastico	Snap ring	Bague d'arret	Haltering	Anillo elástico	
	39	8000 79571	1	Regolatore	Regulator	Régulateur	Regler	Regulador	
	40	8000 62730	1	Vite	Screw	Vis	Schraube	Tornillo	



Note Notes Marka Notas	Pos. No. Index Pos.	N. Cod. Code No. Nr. Code Code Nr N. Cod.	Q.tà Q.ty M.ge C.ad	DENOMINAZIONE	NAME	DESIGNATION	BESHREIBUNG	DENOMINACION	Validità Validity Validité Gültig Validez
	2	80A0 97856	1	Decal per parafango anteriore	Transfer	Decalcomania	Abziehbild	Calcomania	
	3	80B0 97857	1	Decal per portafaro	L.H. transfer	Decalcomania G.	Abziehbild L.	Calcomania izq.	
	4	80A0 97922	1	Decal per convogliatore Dx	R.H. transfer	Decalcomania D.	Abziehbild R.	Calcomania der.	
	5	80A0 97921	1	Decal per convogliatore Sx	L.H. transfer	Decalcomania G.	Abziehbild L.	Calcomania izq.	
	6	8000 A0614	1	Decal per fianchetto Dx	R.H. transfer	Decalcomania D.	Abziehbild R.	Calcomania der.	
	7	8000 A0615	1	Decal per fianchetto Sx	L.H. transfer	Decalcomania G.	Abziehbild L.	Calcomania izq.	
	8	80K0 96951	2	Decal per forcellone	Fork transfer	Decalcomania	Abziehbild	Calcomania	
	11	8000 A2122	1	Decal per parafango posteriore	Rear fender transfer	Decalcomania	Abziehbild	Calcomania	



Note Notes Marka Notas	Pos. No. Index Pos.	N. Cod. Code No. Nr. Code Code Nr N. Cod.	Q.tà Q.ty M.ge C.ad	DENOMINAZIONE	NAME	DESIGNATION	BESHREIBUNG	DENOMINACION	Validità Validity Validité Gültig Validez
	2	80A0 97856	1	Decal per parafango anteriore	Transfer	Decalcomania	Abziehbild	Calcomania	
	3	80B0 97857	1	Decal per portanumero	L.H. transfer	Decalcomania G.	Abziehbild L.	Calcomania izq.	
	4	80A0 97922	1	Decal per convogliatore Dx	R.H. transfer	Decalcomania D.	Abziehbild R.	Calcomania der.	
	5	80A0 97921	1	Decal per convogliatore Sx	L.H. transfer	Decalcomania G.	Abziehbild L.	Calcomania izq.	
	6	8000 A0614	1	Decal per fianchetto Dx	R.H. transfer	Decalcomania D.	Abziehbild R.	Calcomania der.	
	7	8000 A0615	1	Decal per fianchetto Sx	L.H. transfer	Decalcomania G.	Abziehbild L.	Calcomania izq.	
	8	80K0 96951	2	Decal per forcellone	Fork transfer	Decalcomania	Abziehbild	Calcomania	
	11	8000 A2122	1	Decal per parafango posteriore	Rear fender transfer	Decalcomania	Abziehbild	Calcomania	



Note Notes Marka Notas	Pos. No. N. Index Pos.	N. Cod. Code No. Nr. Code Code Nr N. Cod.	Q.tà Q.ty M.ge C.ad	DENOMINAZIONE	NAME	DESIGNATION	BESHREIBUNG	DENOMINACION	Validità Validity Validité Gültig Validez
	2	80A0 97856	1	Decal per parafango anteriore (codice colore E)	Transfer (color code E)	Decalcomania (code couleur E)	Abziehbild (Code Farbe E)	Calcomania (còdigo colòr E)	
	2	8000 A0638	1	Decal per parafango anteriore (codice colore G)	Transfer (color code G)	Decalcomania (code couleur G)	Abziehbild (Code Farbe G)	Calcomania (còdigo colòr G)	
	3	80B0 97857	1	Decal per portafaro (codice colore E)	Transfer (color code E)	Decalcomania G. (code couleur E)	Abziehbild L. (Code Farbe E)	Calcomania izq. (còdigo colòr E)	
	3	8000 A1628	1	Decal per portafaro (codice colore G)	Transfer (color code G)	Decalcomania G. (code couleur G)	Abziehbild L. (Code Farbe G)	Calcomania izq. (còdigo colòr G)	
	4	80A0 97922	1	Decal per convogliatore Dx (codice colore E)	R.H. transfer (color code E)	Decalcomania D. (code couleur E)	Abziehbild R. (Code Farbe E)	Calcomania der. (còdigo colòr E)	
	4	8000 A0640	1	Decal per convogliatore Dx (codice colore G)	R.H. transfer (color code G)	Decalcomania D. (code couleur G)	Abziehbild R. (Code Farbe G)	Calcomania der. (còdigo colòr G)	
	5	80A0 97921	1	Decal per convogliatore Sx (codice colore E)	L.H. transfer (color code E)	Decalcomania G. (code couleur E)	Abziehbild L. (Code Farbe E)	Calcomania izq. (còdigo colòr E)	
	5	8000 A0641	1	Decal per convogliatore Sx (codice colore G)	L.H. transfer (color code G)	Decalcomania G. (code couleur G)	Abziehbild L. (Code Farbe G)	Calcomania izq. (còdigo colòr G)	
	6	8000 A0614	1	Decal per fianchetto Dx (codice colore E)	R.H. transfer (color code E)	Decalcomania D. (code couleur E)	Abziehbild R. (Code Farbe E)	Calcomania der. (còdigo colòr E)	
	6	8000 A1766	1	Decal per fianchetto Dx (codice colore G)	R.H. transfer (color code G)	Decalcomania D. (code couleur G)	Abziehbild R. (Code Farbe G)	Calcomania der. (còdigo colòr G)	
	7	8000 A0615	1	Decal per fianchetto Sx (codice colore E)	L.H. transfer (color code E)	Decalcomania G. (code couleur E)	Abziehbild L. (Code Farbe E)	Calcomania izq. (còdigo colòr E)	
	7	8000 A1765	1	Decal per fianchetto Sx (codice colore G)	L.H. transfer (color code G)	Decalcomania G. (code couleur G)	Abziehbild L. (Code Farbe G)	Calcomania izq. (còdigo colòr G)	
	8	80M0 96951	2	Decal Sx per forcellone (codice colore E)	L.H. swing arm transfer (color code E)	Decalcomania G. (code couleur E)	Abziehbild L. (Code Farbe E)	Calcomania izq. (còdigo colòr E)	
	8	8000 A0284	2	Decal Sx per forcellone (codice colore G)	L.H. swing arm transfer (color code G)	Decalcomania G. (code couleur G)	Abziehbild L. (Code Farbe G)	Calcomania izq. (còdigo colòr G)	
	11	8000 A2122	1	Decal per parafango posteriore	Rear fender transfer	Decalcomania	Abziehbild	Calcomania	

DISEGNO DRAWING DESSIN ZEICHNUNG DIBUJO	TAVOLA DRAWING TABLE BILD TABLA	INDEX NO. POS. N. INDICE	DISEGNO DRAWING DESSIN ZEICHNUNG DIBUJO	TAVOLA DRAWING TABLE BILD TABLA	INDEX NO. POS. N. INDICE	DISEGNO DRAWING DESSIN ZEICHNUNG DIBUJO	TAVOLA DRAWING TABLE BILD TABLA	INDEX NO. POS. N. INDICE	DISEGNO DRAWING DESSIN ZEICHNUNG DIBUJO	TAVOLA DRAWING TABLE BILD TABLA	INDEX NO. POS. N. INDICE	DISEGNO DRAWING DESSIN ZEICHNUNG DIBUJO	TAVOLA DRAWING TABLE BILD TABLA	INDEX NO. POS. N. INDICE
1511 33302	16	16	1611 71701	8	62	1615 28801	2	11	60N3 02461	10	3	8000 02124	3	1
1513 07001	12	2	1611 74601	7	38	1615 29401	2	10	60N4 07335	21	6	8000 08536	2	44
1513 41401	21	11	1611 81604	6	14	1615 29601	2	13	60N4 24962	27	6	8000 08536	14	10
1513 71301	4	4	1611 83701	8	27	1615 30301	2	17	60N4 98033	24	11	8000 13346	22B	3
1513 71401	8	47	1612 35701	8	43	1615 31502	8	3	60N4 98033	25	51	8000 17810	14	21
1513 72201	6	29	1612 36101	8	49	1615 33201	2	4	60N4 98033	27	5	8000 18048	25	17
1513 72602	6	3	1612 36201	8	18	1615 34801	7	14	60N4 98033	27	30	8000 18422	2	32
1513 72602	7	19	1612 36301	8	21	1615 35101	2	15	61N1 15062	8	8	8000 18921	22A	14
1513 74301	21	12	1612 36502	8	41	1615 35801	2	3	61N1 15195	2	1	8000 19768	6	25
1514 10702	21	8	1612 38401	8	33	1615 35902	2	18	61N1 15195	3	22	8000 19789	2	49
1514 13401	1	6	1612 38801	8	46	1615 35902	7	18	61N1 15501	22A	18	8000 20137	25	6
1515 50601	14	34	1612 39001	8	23	1615 38302	9	10	62N0 15682	6	43	8000 20137	27	3
1515 59101	1	5	1612 41501	8	48	1615 38801	8	30	62N1 15504	6	9	8000 20536	14	14
1515 80301	11	10	1612 48001	8	20	1615 39101	7	32	62N1 15504	12	35	8000 20536	14	41
1517 94701	1	1	1612 48101	8	19	1615 39301	3	15	62N1 15519	5	28	8000 20602	24	7
1517 94902	1	8	1612 69901	8	39	1615 40702	2	2	62N1 15547	25	44	8000 20602	27	26
1519 65301	1	2	1612 84201	8	22	1615 40802	3	23	62N1 15567	3	37	8000 21375	3	29
1519 76702	19	16	1614 46901	7	58	1616 36201	7	37	62N1 15658	3	6	8000 21480	6	20
1519 80501	1	4	1614 59002	7	7	1617 95501	2	37	62N4 15547	24	12	8000 21480	18	25
1519 84701	1	13	1614 72801	9	15	1619 69801	1	16	62N4 15547	27	31	8000 21480	22	24
1610 77601	7	8	1615 01404	6	27	60N1 01219	13	62	62N4 15548	9	13	8000 21480	22A	22
1610 77701	6	33	1615 02301	2	14	60N1 02487	9	8	63N0 16374	8	58	8000 22551	18	3
1610 77701	7	10	1615 02501	2	12	60N1 02504	7	75	64N1 20048	12	36	8000 22966	22B	23
1611 08401	7	73	1615 03601	3	17	60N1 02509	7	50	64N1 20068	12	8	8000 23110	6	37
1611 08501	7	67	1615 04201	3	13	60N1 02510	6	15	64N1 20068	18	7	8000 24319	2	48
1611 21601	7	27	1615 04301	3	8	60N1 02510	8	17	66N0 21197	24	13	8000 24962	25	52
1611 27101	7	28	1615 04501	3	11	60N1 02511	2	34	66N0 21197	27	38	8000 26694	25	9
1611 65003	7	13	1615 04901	3	7	60N1 02512	7	47	66N0 21200	24	13	8000 26694	27	4
1611 67702	7	35	1615 08401	3	27	60N1 02513	6	6	66N0 21200	27	38	8000 26694	27	19
1611 68001	7	33	1615 08501	3	28	60N1 02513	7	54	66N0 21205	7	31	8000 26884	6	12
1611 68101	7	34	1615 09501	3	12	60N1 02513	9	6	66N0 21208	7	70	8000 26970	7	20
1611 68401	7	24	1615 09601	3	9	60N1 02515	6	13	66N0 21211	6	21	8000 27960	7	45
1611 68601	7	21	1615 09801	4	3	60N1 02520	6	7	66N0 21211	8	24	8000 28182	6	4
1611 69201	7	22	1615 10501	7	15	60N1 02525	5	6	66N0 21270	22B	22	8000 29043	12	43
1611 69901	8	32	1615 11601	6	26	60N1 02557	2	35	66N0 21270	22C	22	8000 30319	20	2
1611 70101	8	40	1615 12301	3	24	60N1 02866	7	16	66N0 21272	23	24	8000 30326	8	36
1611 70401	7	61	1615 12802	3	21	60N1 02900	7	49	69N4 29004	22C	9	8000 31271	7	66
1611 70601	7	62	1615 13302	1	3	60N1 02927	3	33	69N4 29005	23	7	8000 33288	22A	9
1611 70801	2	8	1615 14104	3	19	60N1 04134	20	7	6BN0 21509	8	15	8000 33373	12	12
1611 70801	7	39	1615 15601	3	10	60N1 07335	2	22	8000 01199	20	6	8000 34002	25	5
1611 71501	8	44	1615 26602	3	4	60N1 07335	7	69	8000 01412	16	19	8000 34002	27	35
1611 71701	8	2	1615 27501	9	14	60N1 07701	22A	17	8000 01688	23	3	8000 34317	8	60

DISEGNO DRAWING DESSIN ZEICHNUNG DIBUJO	TAVOLA DRAWING TABLE BILD TABLA	INDEX NO. POS. N. INDICE	DISEGNO DRAWING DESSIN ZEICHNUNG DIBUJO	TAVOLA DRAWING TABLE BILD TABLA	INDEX NO. POS. N. INDICE	DISEGNO DRAWING DESSIN ZEICHNUNG DIBUJO	TAVOLA DRAWING TABLE BILD TABLA	INDEX NO. POS. N. INDICE	DISEGNO DRAWING DESSIN ZEICHNUNG DIBUJO	TAVOLA DRAWING TABLE BILD TABLA	INDEX NO. POS. N. INDICE	DISEGNO DRAWING DESSIN ZEICHNUNG DIBUJO	TAVOLA DRAWING TABLE BILD TABLA	INDEX NO. POS. N. INDICE
8000 34609	6	40	8000 44240	15	28	8000 56359	25	32	8000 60470	8	55	8000 62728	3	18
8000 35099	7	41	8000 44240	18	32	8000 56377	18	6	8000 60472	7	72	8000 62728	5	10
8000 35531	12	24	8000 44240	21	15	8000 56381	20	4	8000 60472	8	38	8000 62728	11	20
8000 35751	5	15	8000 44240	25	18	8000 56410	6	31	8000 60473	8	37	8000 62728	17	17
8000 35823	8	35	8000 44240	26	4	8000 56443	13	72	8000 60474	7	40	8000 62728	19	11
8000 36137	14	26	8000 45183	6	19	8000 56444	17	31	8000 60475	7	36	8000 62728	19	17
8000 36137	14	31	8000 45194	2	26	8000 56444	25	29	8000 60476	7	6	8000 62729	13	40
8000 36137	14	31	8000 45194	7	71	8000 56444	27	34	8000 60477	7	57	8000 62729	22	37
8000 36467	20	26	8000 45490	19	5	8000 56806	11	21	8000 60577	7	63	8000 62729	22A	15
8000 36786	7	46	8000 45495	11	17	8000 56909	12	33	8000 60577	7	76	8000 62730	2	40
8000 36856	8	53	8000 45495	14	35	8000 56920	1	21	8000 60873	5	23	8000 62730	3	32
8000 36857	8	51	8000 45495	19	36	8000 57155	18	24	8000 60898	12	40	8000 62730	25	36
8000 37299	3	20	8000 45495	20	27	8000 57155	18	26	8000 60898	21	17	8000 62731	3	31
8000 37599	26	16	8000 46664	22A	3	8000 57155	22	23	8000 60969	21	18	8000 62731	14	29
8000 37745	20	10	8000 46893	5	34	8000 57155	22A	21	8000 61078	18	14	8000 62731	14	52
8000 38110	7	30	8000 46893	11	8	8000 57196	4	24	8000 61263	7	5	8000 62731	21	13
8000 38521	16	9	8000 46893	11	11	8000 57242	5	13	8000 61269	7	74	8000 62733	22	12
8000 38748	20	13	8000 46893	15	29	8000 57511	26	1	8000 61275	4	18	8000 62795	14	8
8000 38767	16	15	8000 47422	7	25	8000 58140	7	68	8000 61313	19	4	8000 62795	14	51
8000 38797	17	12	8000 47472	25	47	8000 58207	25	33	8000 61314	13	63	8000 62796	12	14
8000 40449	7	29	8000 47708	2	20	8000 59289	14	24	8000 61355	13	53	8000 62796	13	2
8000 40717	25	43	8000 47763	7	53	8000 59289	14	24	8000 61362	20	9	8000 63312	12	20
8000 41459	12	34	8000 48772	22C	20	8000 59289	14	39	8000 62725	2	52	8000 63312	14	36
8000 41862	24	10	8000 48773	22C	19	8000 59433	12	19	8000 62725	5	26	8000 63424	8	42
8000 41862	27	29	8000 48814	19	32	8000 59434	12	21	8000 62725	5	27	8000 63425	8	9
8000 42022	15	31	8000 48916	17	16	8000 59801	5	9	8000 62725	14	54	8000 63817	2	9
8000 42022	16	26	8000 48917	17	5	8000 59802	5	7	8000 62725	18	18	8000 63821	8	26
8000 42023	16	12	8000 49036	22B	4	8000 59803	5	8	8000 62725	22A	12	8000 63822	8	56
8000 42023	16	18	8000 49654	22	16	8000 59939	3	14	8000 62725	25	54	8000 63829	6	22
8000 42278	2	21	8000 50322	3	47	8000 59940	2	36	8000 62726	19	30	8000 63829	6	22
8000 42345	22A	4	8000 51957	22C	15	8000 59941	3	35	8000 62726	19	35	8000 63830	6	22
8000 42349	18	21	8000 53155	13	61	8000 59942	2	28	8000 62726	20	18	8000 63830	6	22
8000 43391	12	23	8000 53259	18	29	8000 59965	8	2	8000 62726	23	15	8000 63832	6	22
8000 43715	5	4	8000 53259	22	20	8000 59975	7	3	8000 62727	2	39	8000 63832	6	22
8000 43789	6	5	8000 53339	2	38	8000 59976	7	4	8000 62727	11	2	8000 64726	2	5
8000 43928	12	16	8000 53724	18	31	8000 59977	6	17	8000 62727	15	24	8000 64988	3	39
8000 43928	14	30	8000 54073	23	4	8000 60033	24	8	8000 62727	18	12	8000 64988	7	83
8000 43928	14	56	8000 54692	8	7	8000 60033	27	8	8000 62727	19	11	8000 65411	14	38
8000 43928	23	18	8000 55772	22A	16	8000 60233	13	59	8000 62727	19	14	8000 65412	14	37
8000 44240	5	20	8000 55878	23	31	8000 60234	13	60	8000 62727	20	28	8000 65437	17	21
8000 44240	14	33	8000 55902	18	4	8000 60463	8	45	8000 62727	25	31	8000 65464	23	28
8000 44240	14	53	8000 56359	15	27	8000 60464	6	36	8000 62727	26	3	8000 65653	6	16

DISEGNO DRAWING DESSIN ZEICHNUNG DIBUJO	TAVOLA DRAWING TABLE BILD TABLA	INDEX NO. POS. N. INDICE	DISEGNO DRAWING DESSIN ZEICHNUNG DIBUJO	TAVOLA DRAWING TABLE BILD TABLA	INDEX NO. POS. N. INDICE	DISEGNO DRAWING DESSIN ZEICHNUNG DIBUJO	TAVOLA DRAWING TABLE BILD TABLA	INDEX NO. POS. N. INDICE	DISEGNO DRAWING DESSIN ZEICHNUNG DIBUJO	TAVOLA DRAWING TABLE BILD TABLA	INDEX NO. POS. N. INDICE	DISEGNO DRAWING DESSIN ZEICHNUNG DIBUJO	TAVOLA DRAWING TABLE BILD TABLA	INDEX NO. POS. N. INDICE
8000 66101	7	52	8000 69148	19	1	8000 71787	4	12	8000 77884	22C	14	8000 88889	22C	21
8000 66181	22A	7	8000 69149	19	7	8000 71755	25	62	8000 78915	17	18	8000 89089	15	11
8000 66238	20	8	8000 69150	12	4	8000 71806	22	10	8000 79015	1	11	8000 89572	23	26
8000 66395	2	45	8000 69156	2	2	8000 71806	22A	34	8000 79065	22	21	8000 89829	7	78
8000 66427	2	27	8000 69282	13	69	8000 72022	22	13	8000 79066	18	22	8000 89908	4	16
8000 66428	2	7	8000 69282	14	25	8000 72168	16	14	8000 79066	22	22	8000 89910	2	42
8000 66648	20	5	8000 69315	13	57	8000 72268	15	26	8000 79072	18	16	8000 90052	7	60
8000 66651	12	32	8000 69429	15	23	8000 72289	3	42	8000 79075	18	28	8000 90054	7	23
8000 66652	12	26	8000 69429	19	21	8000 72290	3	43	8000 79077	5	2	8000 90056	7	79
8000 66802	1	7	8000 69429	19	22	8000 72426	6	41	8000 79099	22	7	8000 90057	7	77
8000 66807	2	25	8000 69429	20	29	8000 72427	6	11	8000 79571	25	26	8000 90104	22	13
8000 66850	5	12	8000 69715	8	1	8000 72494	25	4	8000 79571	27	39	8000 90104	22A	33
8000 66858	5	19	8000 69722	8	57	8000 72494	27	36	8000 79789	23	28	8000 90107	26	32
8000 67440	20	19	8000 69723	8	59	8000 72868	14	6	8000 80260	13	54	8000 90561	16	23
8000 67449	5	18	8000 69729	8	50	8000 72869	14	50	8000 80277	12	13	8000 91238	15	4
8000 67496	21	7	8000 69736	8	28	8000 72873	14	6	8000 81508	8	13	8000 91288	1	9
8000 67610	5	16	8000 69737	8	54	8000 72874	14	28	8000 81519	8	61	8000 91289	1	14
8000 67700	20	20	8000 69769	7	1	8000 72875	14	27	8000 81628	14	63	8000 91474	13	13
8000 67724	12	27	8000 69783	11	6	8000 72884	14	3	8000 83395	13	3	8000 91479	13	19
8000 67744	2	6	8000 70215	7	80	8000 73140	12	3	8000 84321	7	65	8000 91480	13	48
8000 67821	4	22	8000 70216	7	81	8000 73150	3	2	8000 84665	12	11	8000 91506	13	6
8000 67822	4	23	8000 70217	7	82	8000 73343	18	1	8000 84938	22B	13	8000 91519	13	55
8000 67824	4	11	8000 70277	25	3	8000 73832	14	60	8000 85322	9	7	8000 91610	13	21
8000 67970	11	5	8000 70379	21	9	8000 73834	25	35	8000 85932	18	30	8000 91743	6	18
8000 67997	13	68	8000 70637	1	10	8000 75166	14	9	8000 86136	16	8	8000 92414	23	9
8000 67997	14	12	8000 70696	18	5	8000 75166	14	9	8000 86136	16	21	8000 92797	22B	12
8000 67997	14	12	8000 70698	17	18	8000 75166	14	40	8000 86137	16	22	8000 92797	22C	12
8000 67997	26	5	8000 71028	3	3	8000 75330	17	4	8000 86140	16	7	8000 92797	23	11
8000 68174	7	64	8000 71213	27	14	8000 75584	2	17	8000 86176	16	3	8000 92944	7	51
8000 68195	6	10	8000 71214	27	15	8000 75671	11	9	8000 86177	16	25	8000 92946	11	1
8000 68490	22A	8	8000 71215	27	16	8000 75672	11	15	8000 87119	5	1	8000 92947	11	7
8000 68584	7	48	8000 71216	27	17	8000 75673	11	13	8000 87120	5	3	8000 92948	11	6
8000 68686	7	17	8000 71217	27	18	8000 76283	14	59	8000 87696	25	40	8000 92948	11	6
8000 68690	25	46	8000 71221	27	33	8000 76338	18	10	8000 87812	17	15	8000 92961	15	22
8000 68690	27	37	8000 71445	18	27	8000 76687	17	3	8000 87859	5	17	8000 93011	26	30
8000 68710	7	42	8000 71445	22	14	8000 76688	17	2	8000 88073	4	19	8000 93049	21	5
8000 68905	2	19	8000 71445	22A	32	8000 77373	13	20	8000 88143	12	41	8000 93051	21	3
8000 68908	2	23	8000 71578	17	26	8000 77391	9	3	8000 88231	15	21	8000 93052	21	2
8000 69056	12	29	8000 71578	17	31	8000 77478	9	10	8000 88280	17	1	8000 93072	23	21
8000 69056	12	30	8000 71578	26	27	8000 77715	4	21	8000 88602	25	20	8000 93100	21	5
8000 69111	12	17	8000 71620	14	13	8000 77737	17	11	8000 88602	27	13	8000 93101	17	23
8000 69125	18	2	8000 71623	14	19	8000 77749	22C	24	8000 88887	23	30	8000 93124	16	11

INDICE NUMERICO PROGRESSIVO / NUMERICAL INDEX / INDEX
NUMERIQUE

Husqvarna

NUMMERNVERZEICHNIS / ÍNDICE NUMÉRICO PROGRESIVO

TE 570 - SM 570 R /2003

DISEGNO DRAWING DESSIN ZEICHNUNG DIBUJO	TAVOLA DRAWING TABLE BILD TABLA	INDEX NO. POS. N. INDICE	DISEGNO DRAWING DESSIN ZEICHNUNG DIBUJO	TAVOLA DRAWING TABLE BILD TABLA	INDEX NO. POS. N. INDICE	DISEGNO DRAWING DESSIN ZEICHNUNG DIBUJO	TAVOLA DRAWING TABLE BILD TABLA	INDEX NO. POS. N. INDICE	DISEGNO DRAWING DESSIN ZEICHNUNG DIBUJO	TAVOLA DRAWING TABLE BILD TABLA	INDEX NO. POS. N. INDICE	DISEGNO DRAWING DESSIN ZEICHNUNG DIBUJO	TAVOLA DRAWING TABLE BILD TABLA	INDEX NO. POS. N. INDICE
8000 93216	22A	25	8000 96754	8	4	8000 97593	23	8	8000 99650	24	2	8000 A0615	28	7
8000 93221	25	61	8000 96796	3	30	8000 97615	1	22	8000 99650	27	23	8000 A0615	29	7
8000 93283	13	70	8000 96815	20	23	8000 97747	12	25	8000 99651	24	6	8000 A0615	30	7
8000 93916	21	4	8000 96815	20	23	8000 97749	13	77	8000 99651	27	25	8000 A0627	25	2
8000 93917	21	16	8000 96816	20	22	8000 97750	13	76	8000 99652	24	3	8000 A0633	13	51
8000 94008	9	1	8000 96816	20	22	8000 97977	14	43	8000 99652	27	21	8000 A0633	13	51
8000 94060	22A	31	8000 96817	20	25	8000 97986	4	10	8000 99674	22	11	8000 A0634	26	17
8000 94098	20	3	8000 96818	20	24	8000 98118	15	64	8000 99715	22	1	8000 A0635	27	10
8000 94121	25	15	8000 96828	17	25	8000 98205	2	16	8000 99729	18	15	8000 A0636	26	33
8000 94125	22	3	8000 96828	25	59	8000 98209	17	6	8000 99774	24	9	8000 A0638	30	2
8000 94126	22	4	8000 96830	22	2	8000 98237	13	58	8000 99775	24	1	8000 A0640	30	4
8000 94127	22	5	8000 96831	22	1	8000 98290	2	33	8000 99775	24	1	8000 A0641	30	5
8000 94128	22	6	8000 96832	17	7	8000 98489	15	5	8000 99775	27	20	8000 A0664	24	4
8000 94129	22	9	8000 96833	17	9	8000 98490	15	7	8000 99859	22	38	8000 A0664	27	22
8000 94145	25	60	8000 96835	17	30	8000 98491	15	8	8000 A0080	22B	8	8000 A0672	22A	19
8000 94267	19	24	8000 96838	22B	10	8000 98492	15	9	8000 A0081	22B	9	8000 A0678	26	2
8000 94342	25	37	8000 96869	4	9	8000 98493	15	10	8000 A0085	23	6	8000 A0692	23	14
8000 94411	22A	26	8000 96874	6	35	8000 98494	15	12	8000 A0086	23	7	8000 A0693	23	29
8000 94412	22A	27	8000 96874	7	12	8000 98495	15	20	8000 A0129	9	4	8000 A0694	22A	1
8000 94413	22A	28	8000 96880	2	46	8000 98496	15	15	8000 A0131	10	1	8000 A0747	26	17
8000 94414	22A	29	8000 96881	2	54	8000 98497	15	16	8000 A0136	2	41	8000 A0811	22A	6
8000 94415	22A	30	8000 96888	8	14	8000 98498	15	17	8000 A0192	19	2	8000 A0814	27	1
8000 94488	14	45	8000 96897	13	4	8000 98499	15	18	8000 A0192	19	2	8000 A0843	24	1
8000 94489	14	46	8000 96907	12	42	8000 98512	15	2	8000 A0193	19	1	8000 A0843	27	20
8000 94595	25	30	8000 96908	12	9	8000 98513	15	3	8000 A0227	26	6	8000 A0864	25	23
8000 94709	22C	6	8000 96928	22B	11	8000 98514	15	13	8000 A0228	26	11	8000 A0864	27	11
8000 94713	23	5	8000 96930	22B	21	8000 98515	15	14	8000 A0229	26	25	8000 A0872	5	2
8000 94754	22C	8	8000 96932	22B	18	8000 98517	15	19	8000 A0230	26	26	8000 A0872	5	22
8000 94757	23	6	8000 96933	22B	19	8000 98519	15	3	8000 A0233	25	25	8000 A0879	22A	5
8000 94849	18	26	8000 96934	22	17	8000 98520	15	6	8000 A0233	25	25	8000 A0883	24	5
8000 95341	23	6	8000 96937	23	8	8000 98552	13	22	8000 A0241	19	27	8000 A0883	27	24
8000 95629	22C	11	8000 96938	23	12	8000 98570	15	6	8000 A0278	25	22	8000 A0919	10	2
8000 95696	13	66	8000 96940	23	19	8000 98781	13	41	8000 A0278	27	2	8000 A0928	22	39
8000 95698	13	50	8000 96941	14	18	8000 98782	13	78	8000 A0284	30	8	8000 A0929	22	15
8000 95699	13	49	8000 96944	14	18	8000 98783	13	79	8000 A0349	12	18	8000 A0930	22	25
8000 95702	13	4	8000 96997	1	19	8000 98784	13	80	8000 A0393	22A	20	8000 A0931	18	19
8000 95703	13	1	8000 97049	15	1	8000 98785	13	81	8000 A0434	27	32	8000 A0931	22	19
8000 95751	22C	16	8000 97050	16	5	8000 98786	13	6	8000 A0436	27	1	8000 A0932	22	18
8000 96643	13	5	8000 97052	16	1	8000 98787	13	5	8000 A0600	22	8	8000 A0935	18	34
8000 96645	13	22	8000 97054	16	4	8000 98803	13	21	8000 A0614	28	6	8000 A0936	18	17
8000 96647	13	41	8000 97059	14	1	8000 99521	8	11	8000 A0614	29	6	8000 A0953	25	14
8000 96747	6	42	8000 97590	15	1	8000 99632	22B	16	8000 A0614	30	6	8000 A1021	27	10

DISEGNO DRAWING DESSIN ZEICHNUNG DIBUJO	TAVOLA DRAWING TABLE BILD TABLA	INDEX NO. POS. N. INDICE	DISEGNO DRAWING DESSIN ZEICHNUNG DIBUJO	TAVOLA DRAWING TABLE BILD TABLA	INDEX NO. POS. N. INDICE	DISEGNO DRAWING DESSIN ZEICHNUNG DIBUJO	TAVOLA DRAWING TABLE BILD TABLA	INDEX NO. POS. N. INDICE	DISEGNO DRAWING DESSIN ZEICHNUNG DIBUJO	TAVOLA DRAWING TABLE BILD TABLA	INDEX NO. POS. N. INDICE	DISEGNO DRAWING DESSIN ZEICHNUNG DIBUJO	TAVOLA DRAWING TABLE BILD TABLA	INDEX NO. POS. N. INDICE
8000 A1051	25	53	8000 A2042	22A	41	80B0 84173	3	25	8A00 55860	23	5	8A00 94120	25	16
8000 A1051	27	7	8000 A2043	22A	42	80B0 84174	3	16				8A00 94696	22C	10
8000 A1052	25	55	8000 A2122	28	11	80B0 87800	19	26	8A00 55903	18	13	8A00 95599	22A	23
8000 A1052	27	8	8000 A2122	29	11	80B0 92958	19	9	8A00 59964	9	2	8A00 96746	8	10
8000 A1053	25	56	8000 A2122	30	11	80B0 92958	19	9				8A00 96811	13	1
8000 A1053	27	9	8000 A2352	14	64	80B0 92959	19	10	8A00 60415	2	51	8A00 96819	20	1
8000 A1137	22	39	8000 A2715	2	42	80B0 92959	19	10	8A00 60652	11	19	8A00 96837	23	16
8000 A1189	22A	11	8000 A2716	2	42	80B0 97857	28	3	8A00 62644	14	58	8A00 96890	7	56
8000 A1219	25	58	80A0 42349	20	16	80B0 97857	29	3	8A00 62714	22A	10	8A00 96975	12	1
8000 A1589	19	3	80A0 52662	22A	2	80B0 97857	30	3	8A00 62797	12	28	8A00 97015	13	49
8000 A1589	19	3	80A0 66222	2	50	80C0 69338	13	67	8A00 63644	2	43	8A00 97016	13	50
8000 A1628	30	3	80A0 69551	15	3	80C0 75766	2	24	8A00 65442	23	27	8A00 99475	3	38
8000 A1634	19	3	80A0 70558	13	70	80D0 60559	9	5	8A00 65503	13	56	8A00 A0192	19	2
8000 A1661	1	18	80A0 73426	14	16	80G0 69337	13	66	8A00 66525	6	44	8A00 A0193	19	1
8000 A1662	1	20	80A0 73456	14	15	80G0 69338	13	67	8A00 66661	14	32	8A00 A0545	19	12
8000 A1666	1	17	80A0 74388	14	7	80G0 69338	13	67	8A00 66851	5	14	8A00 A0546	19	12
8000 A1706	22A	38	80A0 75671	11	9	80K0 96951	28	8	8A00 67545	15	25	8A00 A1800	10	16
8000 A1707	22A	36	80A0 75671	11	9	80K0 96951	29	8	8A00 67545	21	14	8A00 A1804	10	20
8000 A1708	22A	35	80A0 87800	19	26	80M0 96951	30	8	8A00 67997	13	52	8A00 A1806	10	21
8000 A1709	22C	16	80A0 89953	12	6	8A00 01815	12	5	8A00 67997	25	38	8A00 A1809	10	12
8000 A1718	2	41	80A0 89962	12	7	8A00 15960	2	47	8A00 68196	6	30	8A00 A1911	12	37
8000 A1722	4	16	80A0 92946	11	1	8A00 15960	2	53	8A00 68201	6	28	8AA0 55705	25	50
8000 A1723	2	42	80A0 92958	19	9	8A00 15960	3	34	8A00 69282	14	57	8AA0 67194	7	43
8000 A1761	19	3	80A0 92959	19	10	8A00 18246	25	13	8A00 69429	19	23	8AA0 73426	14	16
8000 A1762	19	3	80A0 95696	13	66	8A00 20373	25	1	8A00 70379	21	10	8AA0 88856	19	12
8000 A1765	30	7	80A0 96889	7	55	8A00 26846	23	20	8A00 72284	5	32	8AA0 96815	20	23
8000 A1766	30	6	80A0 97856	28	2	8A00 28182	7	2	8A00 72425	6	39	8AA0 96816	20	22
8000 A1794	10	4	80A0 97856	30	2	8A00 28183	4	2	8A00 78326	18	23	8B00 26846	23	10
8000 A1795	10	6	80A0 97921	28	5	8A00 35794	3	5	8A00 78765	2	31	8B00 36022	6	38
8000 A1796	10	5	80A0 97921	29	5	8A00 36022	6	38	8A00 79072	18	16	8B00 38110	7	30
8000 A1798	10	13	80A0 97921	30	5	8A00 37003	7	26	8A00 79754	17	22	8B00 50322	3	47
8000 A1799	10	14	80A0 97922	28	4	8A00 37283	25	19	8A00 81510	8	11	8B00 66525	13	71
8000 A1800	10	15	80A0 97922	29	4	8A00 37283	27	12	8A00 83904	14	2	8B00 68934	17	21
8000 A1803	10	17	80A0 97922	30	4	8A00 38350	8	52	8A00 86177	16	24	8B00 69282	19	25
8000 A1804	10	20	80A0 99774	27	28	8A00 39651	22C	13	8A00 86938	23	9	8B00 70379	21	9
8000 A1807	10	10	80A0 A0233	25	25	8A00 45395	4	25	8A00 88873	25	11	8B00 71154	7	11
8000 A1808	10	11	80A0 A0633	13	51	8A00 48188	6	1	8A00 92876	22C	17	8B00 78437	2	30
8000 A1824	10	18	80A0 A1589	19	3	8A00 50322	3	47	8A00 92986	22B	15	8B00 82879	22C	3
8000 A1883	25	57	80A0 A1761	19	3	8A00 53504	22B	6	8A00 93011	26	31	8B00 82879	23	3
8000 A1910	12	31	80B0 43928	12	10	8A00 55241	18	11	8A00 94010	20	21	8B00 86138	16	13
8000 A2040	22A	39	80B0 43928	12	44	8A00 55241	22B	17	8A00 94060	22A	24	8B00 92792	22C	23
8000 A2041	22A	40	80B0 73832	13	82	8A00 55532	6	2	8A00 94119	25	12	8B00 93066	14	42

INDICE NUMERICO PROGRESSIVO / NUMERICAL INDEX / INDEX
NUMERIQUE

Husqvarna

NUMMERNVERZEICHNIS / ÍNDICE NUMÉRICO PROGRESIVO

TE 570 - SM 570 R /2003

DISEGNO DRAWING DESSIN ZEICHNUNG DIBUJO	TAVOLA DRAWING TABLE BILD TABLA	INDEX NO. POS. N. INDICE	DISEGNO DRAWING DESSIN ZEICHNUNG DIBUJO	TAVOLA DRAWING TABLE BILD TABLA	INDEX NO. POS. N. INDICE	DISEGNO DRAWING DESSIN ZEICHNUNG DIBUJO	TAVOLA DRAWING TABLE BILD TABLA	INDEX NO. POS. N. INDICE	DISEGNO DRAWING DESSIN ZEICHNUNG DIBUJO	TAVOLA DRAWING TABLE BILD TABLA	INDEX NO. POS. N. INDICE	DISEGNO DRAWING DESSIN ZEICHNUNG DIBUJO	TAVOLA DRAWING TABLE BILD TABLA	INDEX NO. POS. N. INDICE
8B00 96837	23	16	8D00 A1806	10	21									
8B00 A0193	19	1	8E00 30053	8	29									
8B00 A1804	10	8	8E00 67545	3	26									
8B00 A1804	10	20	8E00 67545	21	13									
8B00 A1806	10	21	8E00 67545	21	14									
8B0071154	6	32	8E00 69056	12	3									
8BA0 A0545	19	12	8E00 80171	10	19									
8BA0 A0545	19	12	8E00 86138	16	6									
8C00 26846	23	20	8E00 96837	23	16									
8C00 27690	7	59	8E00 99475	11	16									
8C00 28183	4	2	8F00 10789	3	46									
8C00 36022	6	38	8F00 28183	4	2									
8C00 40796	23	17	8F00 38110	7	30									
8C00 50322	3	47	8F00 96837	23	16									
8C00 61121	14	20	8F00 99475	11	14									
8C00 62797	22A	37	8G00 66179	22A	13									
8C00 67997	9	11	8G00 96975	12	1									
8C00 67997	14	23	8G00 A1804	10	20									
8C00 67997	19	28	8H00 28183	4	2									
8C00 68934	17	21	8H00 36022	8	62									
8C00 69056	13	65	8H00 A1804	10	20									
8C00 69112	12	15	8I00 69056	12	39									
8C00 71027	4	17	8J00 96975	12	1									
8C00 75764	7	44	8S00 66179	18	20									
8C00 76026	18	9	8S00 68873	20	12									
8C00 79783	23	27	8T00 80171	10	19									
8C00 93066	14	42	8U00 80171	10	19									
8C00 94010	20	21	8V00 80171	10	7									
8C00 96837	23	16	8W00 80171	10	19									
8C00 96975	12	1	8Y00 80171	10	19									
8C00 A1806	10	9												
8D00 26846	23	10												
8D00 28183	4	2												
8D00 36022	6	38												
8D00 62797	15	30												
8D00 62797	16	17												
8D00 67545	3	30												
8D00 67545	19	20												
8D00 70379	21	1												
8D00 75042	22C	18												
8D00 86176	16	20												
8D00 96837	23	16												

